

2020-21

ANNUAL REPORT





Annual Report 2020-21



Perfection is not attainable, but if we chase perfection we can catch excellence.

Vince Lombardi

CONTENTS



Introduction

Managing Director's Communique	02
About Us	04
Manufacturing Locations	05
Business Verticals	06
Product Range	08
Awards & Certificates	10
Customers	11

Statutory Reports

Corporate Information	12
Notice	13
Board's Report	30
Management Discussion & Analysis Report	41
Report On Corporate Governance	47
Secretarial Audit Report	79

Financials

Independent Auditors' Report	89
Balance Sheet	96
Statement of Profit and Loss	97
Statement of Cash Flow	98
Statement of Changes in Equity	99
Notes to Financial Statements	100

FROM THE DESK OF
**MANAGING
DIRECTOR**

With rapid globalization and foreign direct investment inflow into the Indian automotive industry, the auto components sector is set to create newer opportunities and verticals for further growth.

Dear Stakeholders,

I hope that each one of you and your family members are safe and healthy and are heeding the advisories of the respective governments and taking all necessary precautions.

The year 2020-21 was like no other. It has been amongst the most challenging to-date, with the COVID-19 pandemic causing a scale of suffering that is hard to comprehend. At this difficult moment, our thoughts and prayers extend to all those who have been impacted by this pandemic.

Our main focus during this pandemic year was to ensure the safety and well-being of everyone in the ecosystem. As things stand today, we continue to keep health and safety as our top priority. We have always been people centric and know that our people are our family. We are also of the firm belief that our relationships are the key to our success.

I am confident, however, that with the learnings of the previous wave, the mass vaccination effort and with greater awareness for preventive actions in the society, we will once again overcome this challenging time.

POWER BY RESILIENCE

FY 2020-21 was one of the toughest years for the Automobile Industry. The lockdown caused a cascading effect on the revenue and supply chain processes. While the first half of the year was severely impacted, the second half witnessed a revival in sales owing to the regained consumer confidence and pent-up demand.

With an EBITDA of Rs 26.1 Cr (EBITDA margin 19.7%), Rs 31.8 Cr (EBITDA margin 20.6%) and Rs 30.5 Cr (EBITDA margin 18.9%) in Q2FY21, Q3FY21 and Q4FY21 respectively, Shivam Autotech has delivered astounding results to showcase an industry turnaround and signals positive change for all its shareholders.

The growth reflected is an outcome of Shivam Autotech's strategic business initiatives including new business contracts and investments, an indication of the organization's grit and result-oriented resolve despite the challenges of the last two years. From facing uncertainties like recession in the auto industry on account of BS-VI adoption, followed by the pandemic lockdown, increase in steel prices, supply chain disruption and the overall impact of COVID-19 on the economy, this turnaround is an encouraging



signal for all and I am positive that we will continue with this growth momentum and sustain it in future while we create value for all our stakeholders.

The business diversification strategy devised and implemented to manufacture components for new business verticals like off road vehicles, steering components and construction equipment have been encouraging.

In alignment to PM Modi's vision of Atmanirbhar Bharat, Shivam Autotech has taken multiple initiatives to build a self-reliant infrastructure. To increase the liquidity in the system, the Company has also availed Emergency Credit Line Guarantee Scheme (Scheme) issued by the National Credit Guarantee Trustee Company Limited ("NCGTCL"), a wholly owned Trustee Company of Government of India. Further, the company's focus on building infrastructure to indigenize manufacturing processes has given rise to scope for future exports and saving valuable foreign exchange for India.

The Company also took some Cost saving measures such as merging the Manesar plant with Rohtak plant for operational synergies and cost reductions and optimization of manpower cost by reductions in manpower gradually in non-productive areas.

Shivam Autotech's investments are also focused on the global market to propel growth. Considering the results of Shivam Autotech, its product diversification

to tap newer potential and an upbeat industry scenario, I have no doubt about our ability to materialize our vision and to work strongly towards creating immense value for you, our stakeholders.

No doubt, an environment of fear is eclipsing the industry. But it is equally true that the industry is all set to become the third-largest in the world by 2025, and globalization is considered auspicious rather than a menace.

Shivam Autotech Limited has planned its growth trajectory in the coming quarters by planning product launches. This include differential axles used by the three-wheeler EV segment, currently undergoing trials, besides other products for the aftermarket in both two-wheeler and four-wheeler category viz. filters for two-wheeler, Front axle for tractors & Hybrid kit to convert an ICE car into Hybrid car. The product and vehicle category application mix is as per below table:

Product	Vehicle Application Category
Integrated Differential Axle – 33" / 35"	Electric Rickshaw / E-Cart
Integrated Differential Axle – 46"	L5 3W EV
EV Gearbox	2W EV Scooter + L5 3W EV + 4W EV LCV
Mechanical CBS	2W EV (Drum – Drum System)
Hydraulic CBS	2W EV (Disc – Disc System)
Split Service Braking System	L5 3W EV
Independent service braking system	Quadricycle + L2 3W EV (Export)
Tractor Front Axle	18 – 30 HP 4WD Tractor

With rapid globalization and foreign direct investment inflow into the Indian automotive industry, the auto components sector is set to create newer opportunities and verticals for further growth.

This is a moment to celebrate the trust you have endowed on Shivam Autotech Limited and I look forward to our journey together.

Before I end, I extend my appreciation to the Members of the Board for their support and guidance during this challenging year. I also thank all our suppliers, lenders, colleagues and my leadership team for their relentless effort in achieving our objectives during this difficult times. I would also like to thank you shareholders for your continued trust, confidence, and support in the coming years.

Stay Informed! Stay safe!

Thank you.

Neeraj Munjal
Managing Director

ABOUT THE COMPANY

“Despite the challenges posed by the pandemic, export sales for the FY 2020-21 was Rs. 1,769.62 lakhs as compared to Rs. 894.85 lakhs, registering an increase of 97.76%.”

Shivam Autotech Limited, is one of the largest and most renowned manufacturers of transmission gears and shafts in India. The company has been serving a large number of automobile manufacturers as their strategic and supply chain partners for the past 20 years. Since inception, the Company has undergone a multi-phased development and evolution journey.

Being an integral part of the ‘Make In India’ initiative of the government, we see ourselves as a global manufacturing solution in the auto component segment, and on this note we are proud to mention that apart from 2 wheeler components, we diversified our manufacturing into various verticals and have developed and customized products for automobiles, off road vehicles, aerospace and initiated exports too.

Headquartered in Gurugram, Haryana, the company at present employs 3000+ people and qualifies its capabilities to grow and sustain in the fast changing auto component business environment.

The Company’s principles: Respect, Integrity, Passion, and Excellence, form the core of its strong foundation and commitment. Being a Munjal Group entity, these principles act like the guiding light that have enabled the Company to widen its spectrum of offerings.

The Company strives to build a high-performance organization supported by the trust of all stakeholders and envisions strengthening its presence by solidifying its global footprints.

With experience and expertise par excellence, the company values its customers by delivering value

for money both in the national and international auto component markets. Being a leader within the industry having profound experience of two decades, the company manufactures a comprehensive range of auto components and accessories that primarily include transmission gears, transmission shafts, alternator components, starter motor components, magneto components, steering components and various precision engineering components.

Today, the company’s infrastructure spans pan India across 4 strategic locations including Gurgaon, Haridwar, Bengaluru and Rohtak. An IATF 16949, ISO 45001 & ISO 14001 Certified Company, Shivam Autotech’s Unique Selling Proposition lies in the fact that it is among the very few auto component manufacturers in the country today that makes use of the Near Net Shape Technology for Cold and Warm Forging.

Shivam Autotech Limited employs a stringent quality policy that includes practices like 5S, Kaizen and Poka Yoke as an intrinsic part of its work culture. With robust in-house design and R&D capabilities and continuous collaboration with worldwide manufacturing leaders who are technologically advanced, we have been able to build capacities and capabilities to create indigenous customized products to meet our customer’s need.

All these unique attributes not only set the company apart in India, but also bring an international recognition to it.



Rohtak Plant

MANUFACTURING LOCATIONS



Kolar Plant



Binola Plant



Haridwar Plant

BUSINESS

VERTICALS

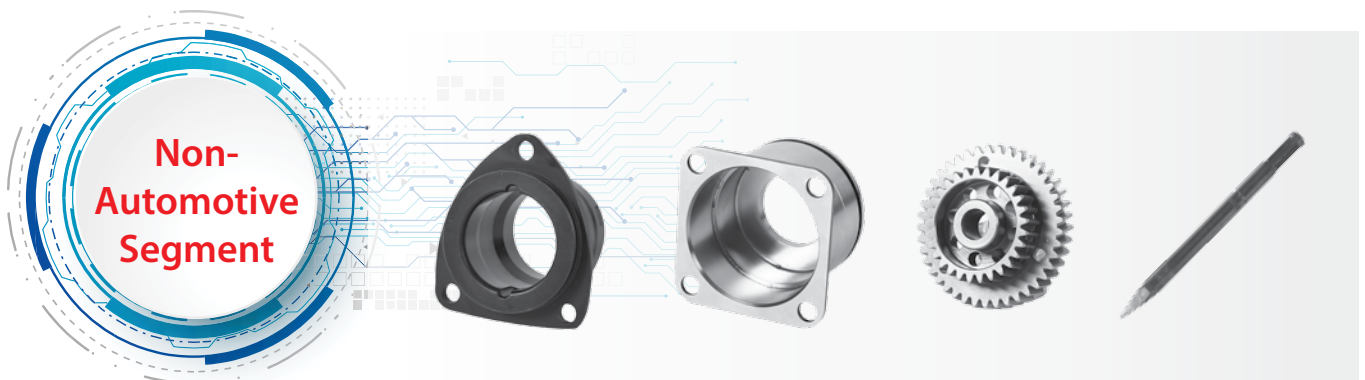
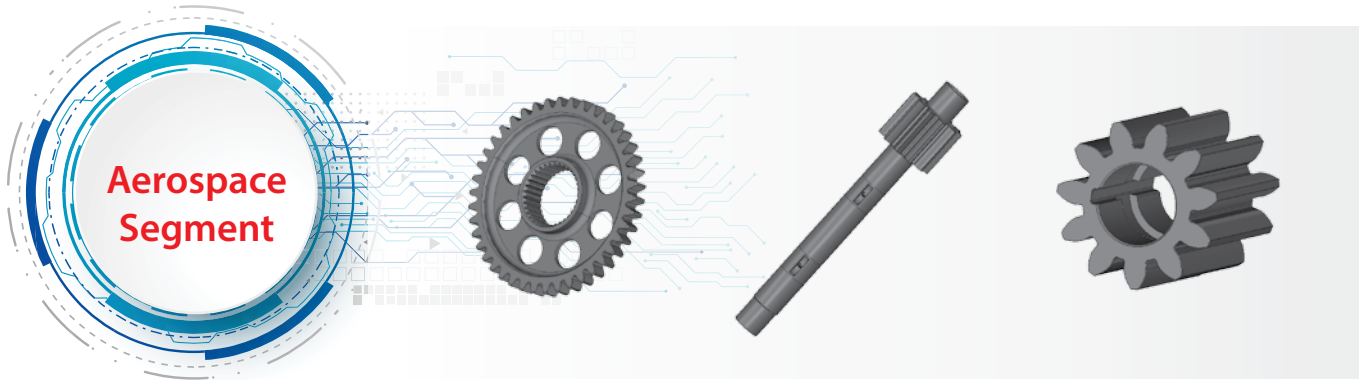
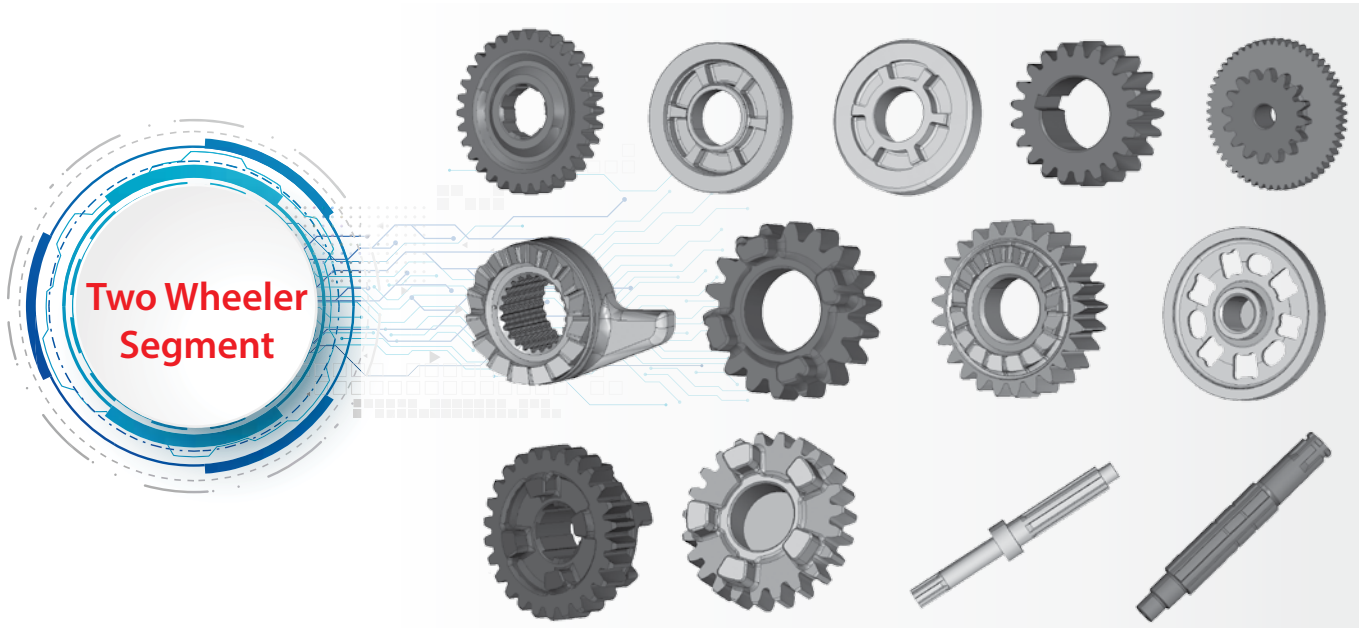

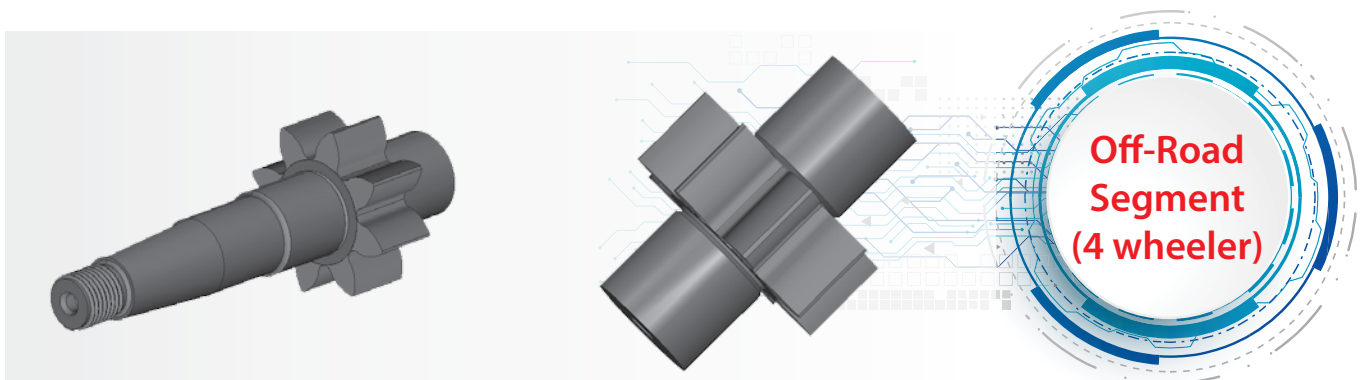
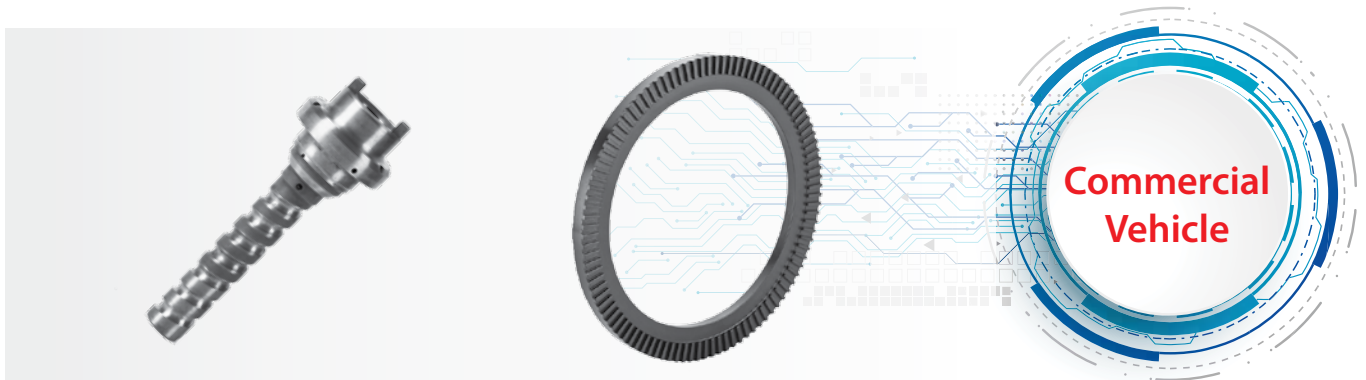
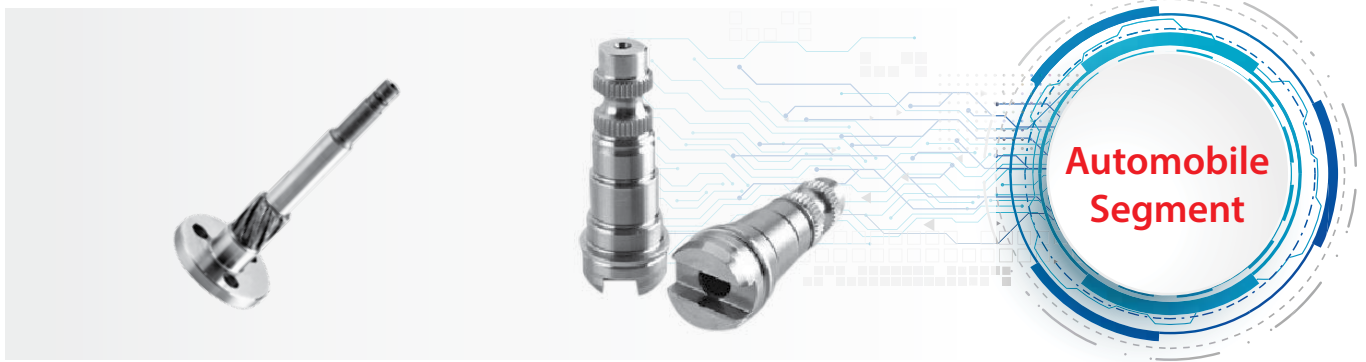
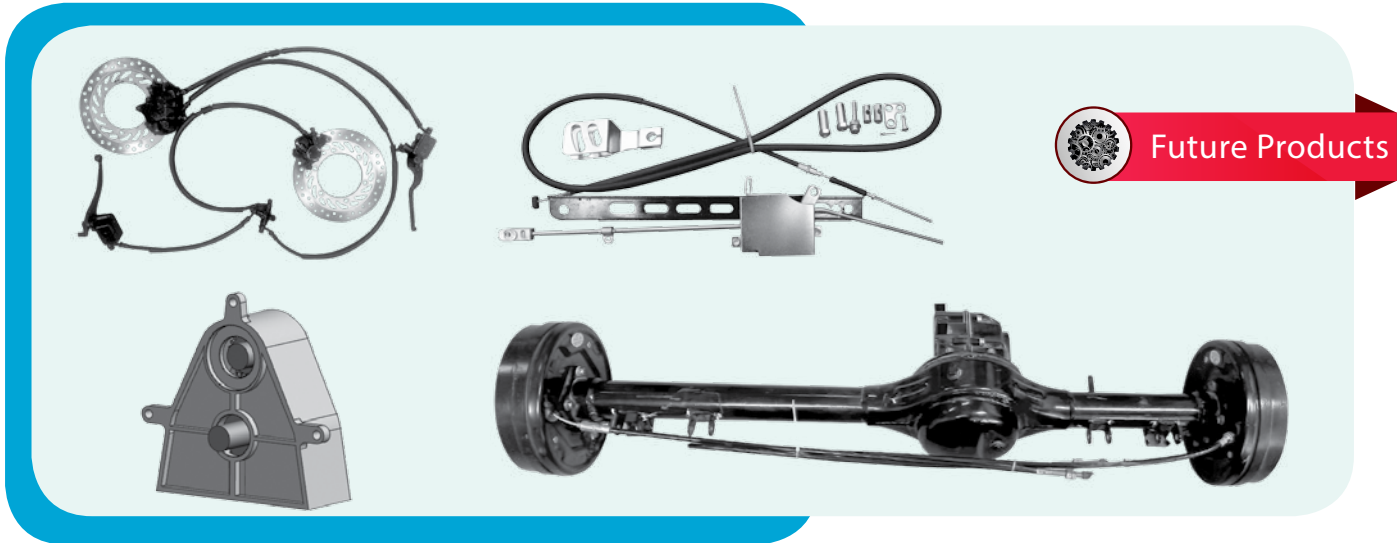

PRODUCT
RANGE

PRECISION
ENGINEERING
COMPONENTS
AND
ASSEMBLIES



TRANSMISSION
GEARS AND
SHAFTS



**STEERING
COMPONENT**



**ALTERNATOR
COMPONENT**



**STARTER
MOTOR
COMPONENTS**



AWARDS &

CERTIFICATES



OUR
CUSTOMERS



BOSCH

DENSO



DYNAMATIC®
TECHNOLOGIES



India Nippon
Electricals Ltd



Mando



MITSUBA

*MUNJAL
SHOWA*



VE COMMERCIAL VEHICLES
A VOLVO GROUP AND EICHER MOTORS JOINT VENTURE



YAMAHA



CORPORATE

INFORMATION

BOARD OF DIRECTORS

CHAIRMAN

Mr. Bhagwan Dass Narang, Independent Director

MANAGING DIRECTOR

Mr. Neeraj Munjal

DIRECTORS

Ms. Jyothi Prasad, Independent Director

Dr. Anil Kumar Gupta, Non-Executive Director

Mrs. Charu Munjal, Executive Director

Mr. Sunil Chinubhai Vakil, Independent Director

COMPANY SECRETARY & COMPLIANCE OFFICER

Ms. Samta Bajaj, Company Secretary

STATUTORY AUDITORS

NSBP & Co.,

Chartered Accountants,

New Delhi

Firm Registration No. 001075N

INTERNAL AUDITORS

JHS & Associates LLP

(Formerly known as N. Kochhar & Co.,)

Chartered Accountants,

New Delhi

LLP Registration No. 133288W/W100099

SECRETARIAL AUDITORS

Satyender Kumar & Associates

Company Secretaries

Gurugram, Haryana

COP No. 5189

FCS No. 4087

BANKERS

IDFC First Bank Limited

Kotak Mahindra Bank Limited

YES Bank Limited

HDFC Bank Limited

REGISTERED OFFICE

10, 1st Floor, Tower A, Emaar Digital Greens,
Sector – 61, Golf Course Extension Road,
Gurugram, Haryana – 122102

BINOLA PLANT

58th Km. Stone, Delhi-Jaipur Highway

Village: Binola-122413, Distt. Gurugram, Haryana

HARIDWAR PLANT

Plot No. 3, Industrial Park-II, Phase-1,

Village Salempur Mehdoon,

District Haridwar, Uttarakhand-249402

BANGALORE PLANT

Plot No. 98, Vemmangal Industrial Area

Kolar - 563101, Karnataka

ROHTAK PLANT

Plot No. 9, Sector 30A, IMT Manesar

District Rohtak -124001, Haryana

REGISTRAR & TRANSFER AGENT

MCS Share Transfer Agent Limited

F-65, First Floor, Okhla Industrial Area,

Phase 1, New Delhi - 110020

NOTICE

Notice is hereby given that the **16th Annual General Meeting** of the Members of **SHIVAM AUTOTECH LIMITED (“the Company”)** will be held on Wednesday, the 29th day of September, 2021 at 12:00 Noon (IST) through Video Conferencing (“VC”) / Other Audio Visual Means (“OAVM”) for which purpose the Registered Office of the Company situated at 10, 1st Floor, Tower A, Emaar Digital Greens, Sector – 61, Golf Course Extension Road, Gurugram, Haryana – 122102 shall be deemed as the venue for the Meeting and the proceedings of AGM shall be deemed to be made thereat, to transact the following businesses:

A. ORDINARY BUSINESS

1. To receive, consider and adopt the Audited Financial Statements including Balance Sheet as at March 31, 2021, the Statement of Profit and Loss and Cash Flow Statement for the financial year ended on that date and the Reports of the Board of Directors’ and Auditor’s thereon.

“RESOLVED THAT the Audited Financial Statements including Balance Sheet as at March 31, 2021 and the Statement of Profit and Loss and Cash Flow Statement for the financial year ended on that date along with the reports of the Board of Directors’ and Auditor’s thereon, as circulated to the members and now placed before the meeting be and are hereby considered and adopted.”

2. To appoint a director in place of Dr. Anil Kumar Gupta (DIN: 02643623), who retires by rotation and being eligible has offered himself for re-appointment.

“RESOLVED THAT pursuant to the provisions of Section 152 and other applicable provisions, if any, of the Companies Act, 2013 and the rules made thereunder (including any statutory modification(s) or re-enactment(s) thereof, for the time being in force), Dr. Anil Kumar Gupta (DIN: 02643623), who retires by rotation and being eligible, offers himself for re-appointment, be and is hereby re-appointed as a Director of the Company, liable to retire by rotation.”

B. SPECIAL BUSINESS

3. Appointment of Mr. Sunil Chinubhai Vakil (DIN: 02527630) as an Independent Director of the Company and in this regard to consider and if thought fit, to pass the following resolution as an **Ordinary Resolution:**

“RESOLVED THAT pursuant to the provisions of Sections 149, 150 and 152 read with Schedule IV and other applicable provisions, if any, of the Companies Act, 2013 and the Companies (Appointment and Qualification of Directors) Rules, 2014, the applicable provisions of the SEBI (Listing Obligations and Disclosure Requirements) Regulations, 2015 (including any statutory modification(s) or re-enactment(s) thereof, for the time being in force) and based on the recommendation of the Nomination and Remuneration Committee of the Company, Mr. Sunil Chinubhai Vakil (DIN: 02527630) who was appointed as an Additional (Non-Executive and Independent) Director of the Company pursuant to Section 161 and other applicable provisions with effect from December 21, 2020 to hold office upto the date of this Annual General Meeting and in respect of whom the Company has received a notice in writing from him under Section 160 of the Companies Act, 2013 proposing his candidature for the office of director, be and is hereby appointed as an Independent Director of the Company, not liable to retire by rotation, in order to fill the casual vacancy caused by the resignation of Mr. Sunil Kant Munjal, Independent Director to hold office for a term of 4 (four) consecutive years, from the date of appointment.”

4. Re-appointment of Mr. Neeraj Munjal (DIN: 00037792) as Managing Director (designated as Executive Director) of the Company and in this regard to consider and if thought fit, to pass, the following resolution as a **Special Resolution:**

“RESOLVED THAT pursuant to the provisions of Section 190, 196, 197, 198 & 203 read with Schedule V and other applicable provisions, if any, of the Companies Act, 2013 and the Companies (Appointment and Remuneration of Managerial Personnel) Rules, 2014, SEBI (Listing Obligations and Disclosure Requirements) Regulations, 2015 (“Listing Regulations”) (including any statutory modification(s) or re-enactment thereof for the time being in force), the Articles of Association of the Company and based on the recommendations of the Nomination and Remuneration Committee and approval of the Board, and in accordance with the Nomination and Remuneration Policy of the Company and such other approvals as may be necessary, the consent of the members of the Company be and is hereby accorded for re-appointment of Mr. Neeraj Munjal (DIN: 00037792) as Managing Director of the

Company categorized as “Key Managerial Personnel” for a further period of 5 years with effect from April 01, 2021 till March 31, 2026 on the existing remuneration as set out in the explanatory statement annexed to the Notice convening this Annual General Meeting.

RESOLVED FURTHER THAT Mr. Neeraj Munjal shall be liable to retire by rotation in pursuance of Section 152 and any other provisions of the Companies Act, 2013.

RESOLVED FURTHER THAT in accordance with the provisions of Sections 196, 197, 198 and 203 read with Schedule V and other applicable provisions, if any, of the Companies Act, 2013 read with Rules framed thereunder and the Listing Regulations (including any statutory modification(s) or re-enactment thereof for the time being in force), consent of the Members of the company be and is hereby accorded that if in any financial year during the tenure of Mr. Neeraj Munjal, the Company has no profits, or its profits are inadequate the Company shall pay the remuneration

to Mr. Neeraj Munjal, as set out in the Explanatory Statement, annexed to the notice convening this meeting as the minimum remuneration for a period of three years effective from April 01, 2021 till March 31, 2024.

RESOLVED FURTHER THAT for the purpose of giving effect to this resolution, the Board of Directors of the Company (including its committee thereof) be and are hereby authorized to do all such acts, deeds and things and execute all such documents, instruments and writings as may be required including, to alter and vary the terms and conditions of appointment and / or remuneration including designation, subject to the same not exceeding the limits as specified in section 197 read with Schedule V to the Companies Act, 2013 or other statutory modification(s) or re-enactment thereof and to delegate all or any of its powers herein conferred to any Committee of Directors to give effect to the aforesaid resolution without further reference to the Company in General Meeting.”

Place: Gurugram

Date: August 13, 2021

Registered Office:

10, 1st Floor, Tower A, Emaar Digital Greens,
Sector – 61, Golf Course Extension Road,
Gurugram, Haryana - 122102

CIN: L34300HR2005PLC081531

e-mail: info@shivamautotech.com

website: www.shivamautotech.com

Tel: +91 124 4698700 Fax: +91 124 4698798

**By Order of the Board of Directors
For Shivam Autotech Limited**

Sd/-

Samta Bajaj

Company Secretary

Membership No. 50269

NOTES

- In view of the current extraordinary circumstances due to COVID-19 pandemic, social distancing is a norm to be followed, the Ministry of Corporate Affairs (“MCA”) has vide its General Circular No. 02/2021 dated January 13, 2021 read with General Circular Nos., 14/2020 dated April 8, 2020, 17/2020 dated April 13, 2020 & 20/2020 dated May 5, 2020 and SEBI Circular No. SEBI/HO/CFD/CMD 2/CIR/P/2021/11 dated January 15, 2021 read with SEBI Circular No. SEBI/HO/CFD/CMD1/CIR/P/2020/79 dated May 12, 2020 issued by the Securities and Exchange Board of India (SEBI) (hereinafter collectively referred to as “Circulars”) permitted the holding of the Annual General Meeting (“AGM”) due to be held in the year 2020 or become due in the year 2021 (i.e. till December 31, 2021) through VC / OAVM, without the physical presence of the Members at a common venue. In compliance with the provisions of the Companies Act, 2013 (“the Act”), SEBI (Listing Obligations and Disclosure Requirements) Regulations, 2015 (“SEBI Listing Regulations”) and Circulars as mentioned above, the 16th AGM of the Company is being held through VC / OAVM.
- The deemed venue for 16th AGM shall be the Registered Office of the Company.
- The relevant details, pursuant to Regulations 26(4) and 36(3) of the SEBI Listing Regulations and Secretarial Standards on General Meetings (SS-2) issued by the Institute of Company Secretaries of India, in respect of director seeking appointment/re-appointment at this AGM forms an integral part of the Notice.
- The Explanatory Statement pursuant to Section 102(1) of the Act, relating to the Special Business to be transacted at the AGM under Item No. 3 & 4 of the accompanying notice is annexed hereto.
- Pursuant to the provisions of the Act, a Member entitled to attend and vote at the AGM is entitled to appoint

a proxy to attend and vote on his/her behalf and the proxy need not be a Member of the Company. **Since this AGM is being held pursuant to the Circulars mentioned above through VC / OAVM, physical attendance of Members has been dispensed with. Accordingly, the facility for appointment of proxies by the Members under Section 105 of the Act will not be available for this AGM and hence the Proxy Form, Attendance Slip and route map are not annexed to this Notice.**

6. Pursuant to Section 113 of the Act, members of the Company under the category of Institutional Investors/ Corporate members are encouraged to attend and vote at the AGM through VC. Corporate members (i.e. other than individuals / HUF, NRI, etc.) are requested to send a certified copy (PDF/JPG Format) of its Board or governing body resolution/Authorization letter etc., to the Scrutinizer by email through its registered email address at satyenderfcs@gmail.com with a copy marked to helpdesk.evoting@cdislindia.com and cs@shivamautotech.com, authorizing its representative to attend the AGM through VC / OAVM on its behalf and to vote through remote e-voting or through e-voting at the AGM..
7. As per Regulation 40 of SEBI Listing Regulations, as amended, securities of listed companies can be transferred only in dematerialized form with effect from, April 1, 2019, except in case of requests received for transmission or transposition of securities. In view of this and to eliminate all risks associated with physical shares and for ease of portfolio management, members holding shares in physical form are requested to consider converting their holdings to dematerialized form. Members can contact the Company or Company's Registrar and Transfer Agent, MCS Share Transfer Agent Limited ("Registrar") for assistance in this regard.
8. The Securities and Exchange Board of India ("SEBI") has mandated submission of Permanent Account Number ('PAN') by every participant in securities market. Members holding shares in electronic form are, therefore, requested to submit their PAN to their DPs. Members holding shares in physical form are required to submit their PAN details to the Registrar.
9. Members are requested to direct notifications about changes, if any, pertaining to their name, postal address, email address, telephone/ mobile numbers, Permanent Account Number (PAN), nominations, power of attorney, bank details such as, name of the bank and branch details, bank account number, MICR code, IFSC code, a scanned copy of the cancelled cheque bearing the name of the first member etc., to their DPs in case the shares are held by them in electronic form and to Registrar at email address admin@mcsregistrars.com in case the shares are held by them in physical form.
10. Members holding shares in physical form, in identical order of names, in more than one folio are requested to send to the Registrar, the details of such folios together with the share certificates for consolidating their holdings in one folio to facilitate better service. A consolidated share certificate will be issued to such Members after making requisite changes.
11. As per the provisions of Section 72 of the Act, the facility for making nomination is available for the Members in respect of the shares held by them. Members who have not yet registered their nomination are requested to register the same by submitting Form No. SH- 13. The said form can be downloaded from-
<http://ebook.mca.gov.in/notificationdetail.aspx?acturl=6CoJDC4uKVUR7C9FI4rZdatyDbeJTqg38iljdoCCVy5oIaqWqXUJS57H9RSp+M6u>.
Members are requested to file the nomination form with their respective DPs in case the shares are held by them in electronic form and to Registrar at - MCS Share Transfer Agent Limited, F-65, Okhla Industrial Area, Phase-1, New Delhi- 110020; Tel No. : 011-41406149-52; email id: helpdeskdelhi@mcsregistrars.com in case the shares are held in physical form.
12. Members seeking any information with regard to the accounts or any matter to be placed at the AGM, are requested to write to the Company on or before September 23, 2021 from their registered email address, mentioning their name, DP ID and Client ID number/folio number and mobile number at Company's investor email id: cs@shivamautotech.com. The same will be replied to by the Company suitably.
13. All documents referred to in the Notice and explanatory statement and Statutory Registers i.e. Register of Directors and Key Managerial Personnel and their shareholding maintained under Section 170 of the Act and the Register of Contracts or Arrangements in which directors are interested maintained under Section 189 of the Act, will be available for inspection in electronic mode from the date of circulation of this Notice upto the date of AGM and will also be available for inspection during the AGM. Members may request the same by sending an email at cs@shivamautotech.com from their registered email addresses.
14. In compliance with the aforesaid Circulars, Notice of the AGM along with the Annual Report 2020-21 is being sent only through electronic mode to those Members whose email addresses are registered with the Company/ Depositories. Members may note that the Notice and Annual Report 2020-21

will also be available on the Company's website www.shivamautotech.com, websites of the Stock Exchanges i.e. The BSE Limited and The National Stock Exchange of India Limited at www.bseindia.com and www.nseindia.com respectively, and on the website of CDSL at <https://www.evotingindia.com>.

15. We urge members to support the 'Green Initiative' by choosing to receive the Company's communication through e-mail. Members who have not yet registered their e-mail addresses are requested to register the same with their DPs in case the shares are held by them in electronic form and with Registrar by sending a scan copy of a signed request letter mentioning your Folio No., Name of shareholder, complete address, e-mail address to be registered along with scanned copy of the share certificate(s) (front and back), PAN (self-attested scanned copy of PAN card), AADHAR (self-attested scanned copy of Aadhar Card) with subject as **"Shivam Autotech Limited – Member Email ID"** at admin@mcsregistrars.com or at Company's e-mail ID: cs@shivamautotech.com in case the shares are held by them in physical form.
16. Members attending the AGM through VC / OAVM shall be counted for the purpose of reckoning the quorum under Section 103 of the Act.
17. At the 12th AGM held on September 29, 2017, the Members approved appointment of NSBP & CO., Chartered Accountants, New Delhi (Firm Registration No. 001075N) as Statutory Auditors of the Company to hold office for a period of five years from the conclusion of that AGM till the conclusion of the 17th AGM, subject to ratification of their appointment by Members at every AGM, if so required under the Act. The requirement to place the matter relating to appointment of auditors for ratification by Members at every AGM has been done away by the Companies (Amendment) Act, 2017 with effect from May 7, 2018. Accordingly, no resolution is being proposed for ratification of appointment of Statutory Auditors at the 16th AGM.
18. Pursuant to Section 91 of the Act, the Register of Members and Share Transfer Books of the Company will remain closed from Monday, September 20, 2021 to Wednesday, September 29, 2021 (both days inclusive).
19. Pursuant to the provisions of Section 124 of the Act read with Investor Education and Protection Fund Authority (Accounting, Audit, Transfer and Refund) Rules, 2016 ("IEPF Rules"), dividend which remains unpaid or unclaimed for a period of seven consecutive years from the date of its transfer to unpaid dividend account, is required to be transferred by the Company to Investor Education and Protection

Fund (IEPF), established by the Central Government under the provisions of Section 125 of the Act. The details of unpaid amounts as per provisions of Section 124 of the Act are uploaded under 'Investor Services' section on the website of the Company viz. www.shivamautotech.com.

The dividend declared by the Company for the financial year 2013-14, of which Rs. 7,51,189.82/- has remain unpaid/unclaimed shall be transferred to IEPF on or before December 04, 2021. Accordingly, Members who have not encashed their Dividend Warrant(s) are requested to approach the Company for releasing the dividend upon completion of necessary formalities for the same in lieu of such warrant(s). Unclaimed/unpaid final dividend for the financial year 2013-14, which is due for transfer to IEPF, should be claimed by the Members before November 04, 2021. After that date, no claim shall lie against the Company, in respect of the said amount.

Due dates for transfer of unclaimed/unpaid dividends for the financial year ending March 31, 2014 and thereafter to IEPF:

FY ended	Last date of payment to shareholder / Due date	Last Date of transfer to IEPF
March 31, 2014	November 04, 2021	December 04, 2021
March 31, 2015	October 15, 2022	November 14, 2022
March 31, 2016	November 04, 2023	December 04, 2023

20. Pursuant to the provisions of Section 124(6) of the Act read with Rule 6 of Investor Education and Protection Fund Authority (Accounting, Audit, Transfer and Refund) Rules, 2016 notified by the Ministry of Corporate Affairs as amended from time to time ("the Rules") shares in respect of which dividend remains unpaid or unclaimed for seven consecutive years or more is required to be transferred by the Company within a period of thirty days of such shares becoming due to be transferred to Investor Education and Protection Fund (IEPF), established by the Central Government under the provisions of Section 125 of the Act. The details of unpaid amounts as per provisions of Section 124 of the Act are uploaded under "Investor Services" section on the website of the Company viz. www.shivamautotech.com. The concerned members are requested to verify the details of their unclaimed amounts, if any, and write to the Company before the same becoming due for transfer to the IEPF.

Adhering to the various requirements set out in the Investor Education and Protection Fund Authority (Accounting, Audit, Transfer and Refund) Rules, 2016, as amended, the Company has, during financial year 2020-21, transferred to the IEPF Authority all shares

in respect of which dividend had remained unpaid or unclaimed for seven consecutive years or more as on the due date of transfer, i.e. November 29, 2020. Details of shares transferred to the IEPF Authority are available on the website of the Company and the same can be accessed through the link: http://www.shivamautotech.com/pdf/n1_unclaim_div_shivam_25112020.pdf

The said details have also been uploaded on the website of the IEPF Authority and the same can be accessed through the link: www.iepf.gov.in.

21. Members may note that shares as well as unclaimed dividends transferred to IEPF Authority can be claimed back from them by making an online application to the IEPF Authority in web Form No. IEPF-5 available on www.iepf.gov.in. or contact Company's Registrar and Transfer Agent for lodging claim for refund of shares and / or dividend from the IEPF Authority.
22. To prevent fraudulent transactions, members are advised to exercise due diligence and notify the Company of any change in address or demise of any Member as soon as possible. Members are also advised to not leave their demat account(s) dormant for long. Periodic statement of holdings should be obtained from the concerned Depository Participant and holdings should be verified from time to time.
23. Central Depository Services (India) Limited ("CDSL") will be providing facility for voting through remote e-Voting, for participation in the 16th AGM through VC/OAVM Facility and e-Voting during the 16th AGM.
24. Instructions for e-voting and joining the AGM are as follows:

A. Instructions for Voting through electronic mode

- i. In compliance with the provisions of Section 108 of the Act, read with Rule 20 of the Companies (Management and Administration) Rules, 2014, as amended from time to time, Secretarial Standard on General Meetings (SS-2) issued by the Institute of Company Secretaries of India ("ICSI") and Regulation 44 of the SEBI Listing Regulations read with Circulars as mentioned above, the Members are provided with the facility to cast their vote electronically, through the remote e-voting services provided by CDSL, in respect of the businesses to be transacted at the 16th AGM and facility for those Members participating in the 16th AGM to cast vote through e-Voting system during the AGM.. The manner of voting remotely by members holding shares in dematerialized

mode, physical mode and for members who have not registered their email addresses is provided in the instructions for e-voting section which forms part of this Notice.

- ii. The remote e-voting period begins on 09:00 A.M. IST on Sunday, September 26, 2021 and ends 05:00 P.M. IST on Tuesday, September 28, 2021. During this period members of the Company, holding shares either in physical form or in dematerialized form, as on the cut-off date Wednesday, September 22, 2021, may cast their vote electronically. The e-voting module shall be disabled by CDSL for voting thereafter. Those Members, who will be present in the AGM through VC / OAVM facility and have not cast their vote on the Resolutions through remote e-voting and are otherwise not barred from doing so, shall be eligible to vote through e-voting system during the AGM.
- iii. A person who is not a Member as on the cut-off date should treat this Notice of 16th AGM for information purpose only.
- iv. Pursuant to SEBI Circular No. **SEBI/HO/CFD/CMD/CIR/P/2020/242 dated 09.12.2020**, under Regulation 44 of Securities and Exchange Board of India (Listing Obligations and Disclosure Requirements) Regulations, 2015, listed entities are required to provide remote e-voting facility to its shareholders, in respect of all shareholders' resolutions. However, it has been observed that the participation by the public non-institutional shareholders/retail shareholders is at a negligible level.

Currently, there are multiple e-voting service providers (ESPs) providing e-voting facility to listed entities in India. This necessitates registration on various ESPs and maintenance of multiple user IDs and passwords by the shareholders.

In order to increase the efficiency of the e-voting process, pursuant to a public consultation, it has been decided to enable e-voting to **all the demat account holders, by way of a single login credential, through their demat accounts/ websites of Depositories/ Depository Participants**. Demat account holders would be able to cast their vote without having to register again with the ESPs, thereby, not only facilitating seamless authentication but also enhancing ease and convenience of participating in e-voting process.

- v. In terms of **SEBI circular no. SEBI/HO/CFD/CMD/CIR/P/2020/242 dated December 9, 2020** on e-Voting facility provided by Listed Companies, Individual shareholders holding securities in demat mode are allowed to vote through their demat account maintained with Depositories and Depository Participants. Shareholders are advised to update their mobile number and email Id in their demat accounts in order to access e-Voting facility.

Pursuant to above said SEBI Circular, Login method for e-Voting and joining virtual meetings **for Individual shareholders holding securities in Demat mode** is explained herein below:

Type of shareholders	Login Method
Individual Shareholders holding securities in Demat mode with CDSL	<ol style="list-style-type: none"> 1) Users who have opted for CDSL Easi / Easiest facility, can login through their existing user id and password. Option will be made available to reach e-Voting page without any further authentication. The URLs for users to login to Easi / Easiest are https://web.cdslindia.com/myeasi/home/login or visit www.cdslindia.com and click on Login icon and select New System Myeasi. 2) After successful login the Easi / Easiest user will be able to see the e-Voting Menu. On clicking the e-voting menu, the user will be able to see his/her holdings along with links of the respective e-Voting service provider i.e. CDSL/ NSDL/ KARVY/ LINK INTIME as per information provided by Issuer / Company. Additionally, we are providing links to e-Voting Service Providers, so that the user can visit the e-Voting service providers' website directly. 3) If the user is not registered for Easi/Easiest, option to register is available at https://web.cdslindia.com/myeasi/Registration/EasiRegistration 4) Alternatively, the user can directly access e-Voting page by providing Demat Account Number and PAN No. from a e-Voting link available on www.cdslindia.com home page. The system will authenticate the user by sending OTP on registered Mobile & Email as recorded in the Demat Account. After successful authentication, user will be provided links for the respective ESP where the e-Voting is in progress during or before the AGM.
Individual Shareholders holding securities in demat mode with NSDL	<ol style="list-style-type: none"> 1) If you are already registered for NSDL IDeAS facility, please visit the e-Services website of NSDL. Open web browser by typing the following URL: https://eservices.nsdl.com either on a Personal Computer or on a mobile. Once the home page of e-Services is launched, click on the "Beneficial Owner" icon under "Login" which is available under 'IDeAS' section. A new screen will open. You will have to enter your User ID and Password. After successful authentication, you will be able to see e-Voting services. Click on "Access to e-Voting" under e-Voting services and you will be able to see e-Voting page. Click on company name or e-Voting service provider name and you will be re-directed to e-Voting service provider website for casting your vote during the remote e-Voting period or joining virtual meeting & e-voting during the meeting. 2) If the user is not registered for IDeAS e-Services, option to register is available at https://eservices.nsdl.com. Select "Register Online for IDeAS "Portal or click at https://eservices.nsdl.com/SecureWeb/IdeasDirectReg.jsp 3) Visit the e-Voting website of NSDL. Open web browser by typing the following URL: https://www.evoting.nsdl.com/ either on a Personal Computer or on a mobile. Once the home page of e-Voting system is launched, click on the icon "Login" which is available under 'Shareholder/Member' section. A new screen will open. You will have to enter your User ID (i.e. your sixteen digit demat account number hold with NSDL), Password/OTP and a Verification Code as shown on the screen. After successful authentication, you will be redirected to NSDL Depository site wherein you can see e-Voting page. Click on company name or e-Voting service provider name and you will be redirected to e-Voting service provider website for casting your vote during the remote e-Voting period or joining virtual meeting & e-voting during the meeting.

Individual Shareholders (holding securities in demat mode) login through their Depository Participants	You can also login using the login credentials of your demat account through your Depository Participant registered with NSDL/CDSL for e-Voting facility. After Successful login, you will be able to see e-Voting option. Once you click on e-Voting option, you will be redirected to NSDL/CDSL Depository site after successful authentication, wherein you can see e-Voting feature. Click on company name or e-Voting service provider name and you will be redirected to e-Voting service provider's website for casting your vote during the remote e-Voting period or joining virtual meeting & e-voting during the meeting.
---	--

Important note: Members who are unable to retrieve User ID/ Password are advised to use Forget User ID and Forget Password option available at abovementioned website.

Helpdesk for Individual Shareholders holding securities in demat mode for any technical issues related to login through Depository i.e. CDSL and NSDL

Login type	Helpdesk details
Individual Shareholders holding securities in Demat mode with CDSL	Members facing any technical issue in login can contact CDSL helpdesk by sending a request at helpdesk.evoting@cdslindia.com or contact at 022- 23058738 and 22-23058542-43.
Individual Shareholders holding securities in Demat mode with NSDL	Members facing any technical issue in login can contact NSDL helpdesk by sending a request at evoting@nsdl.co.in or call at toll free no.: 1800 1020 990 and 1800 22 44 30

vi. The details of the process and manner for remote e-voting and joining virtual meetings for **Physical shareholders and shareholders other than individuals holding in Demat form** are explained herein below:

- a. Visit the e-Voting website of CDSL by typing the following URL: www.evotingindia.com.
- b. Once the home page of e-Voting system is launched, Click on "Shareholders" module.
- c. Now Enter your User ID
 - For CDSL: 16 digits beneficiary ID,
 - For NSDL: 8 Character DP ID followed by 8 Digits Client ID,
 - Members holding shares in physical form should enter Folio Number registered with the Company.

- d. Next enter the Image Verification as displayed and Click on Login.
- e. If you are holding shares in demat form and had logged on to www.evotingindia.com and voted on an earlier voting of any company, then your existing password is to be used.
- f. If you are a first time user follow the steps given below:

	For Physical shareholders and shareholders holding shares in Demat Form other than individual.
PAN	Enter your 10 digit alpha-numeric PAN issued by Income Tax Department (Applicable for both demat shareholders as well as physical shareholders). Members who have not updated their PAN with the Company/Depository Participant may call CDSL's toll free number 1800225533.
Dividend Bank Details or Date of Birth (DOB)	Enter the Dividend Bank Details or Date of Birth (in dd/mm/yyyy format) as recorded in your demat account or in the company records in order to login If both the details are not recorded with the depository or company please enter the member id / folio number in the Dividend Bank details field as mentioned in instruction (c)

- g. After entering these details appropriately, click on "SUBMIT" tab.

- h. Members holding shares in physical form will then directly reach the Company selection screen. However, members holding shares in demat form will now reach 'Password Creation' menu wherein they are required to mandatorily enter their login password in the new password field. Kindly note that this password is to be also used by the demat holders for voting for resolutions of any other company on which they are eligible to vote, provided that company opts for e-voting through CDSL platform. It is strongly recommended not to share your password with any other person and take utmost care to keep your password confidential.
- i. If demat account holder has forgotten the login password then enter the User ID and the image verification code and click on Forgot Password & enter the details as prompted by the system.
- j. After successful login, you will be able to see the Home page of e-Voting. Click on the EVSN for the "Shivam Autotech Limited" on which you choose to vote.
- k. On the voting page, you will see "RESOLUTION DESCRIPTION" and against the same the option "YES/NO" for voting. Select the option YES or NO as desired. The option YES implies that you assent to the Resolution and option NO implies that you dissent to the Resolution.
- l. Click on the "RESOLUTIONS FILE LINK" if you wish to view the entire Resolution details.
- m. After selecting the resolution you have decided to vote on, click on "SUBMIT". A confirmation box will be displayed. If you wish to confirm your vote, click on "OK", else to change your vote, click on "CANCEL" and accordingly modify your vote.
- n. Once you "CONFIRM" your vote on the resolution, you will not be allowed to modify your vote.
- o. You can also take out print of the voting done by you by clicking on "Click here to print" option on the Voting page.

B. PROCESS FOR THOSE SHAREHOLDERS WHOSE EMAIL IDS/MOBILE NO. ARE NOT REGISTERED WITH THE COMPANY/DEPOSITORIES FOR PROCURING USER ID AND PASSWORD FOR E-VOTING ON THE RESOLUTIONS SET OUT IN THIS NOTICE.

For Physical shareholders- please provide scanned copy of a duly signed letter by the member(s) mentioning necessary details like Folio No., name of shareholder, scanned copy of the share certificate (front and back), PAN (self-attested scanned copy of PAN card), AADHAR (self-attested scanned copy of Aadhar Card) by sending a request to Registrar/Company at helpdeskdelhi@mcsregistrars.com or cs@shivamautotech.com respectively.

For shareholders helpdeskdelhi@mcsregistrars.com holding shares in dematerialised form – please provide Demat account details (CDSL 16-digit beneficiary ID or NSDL-16 digit DPID + CLID), Name of shareholder, client master or copy of Consolidated Account statement, PAN (self-attested scanned copy of PAN card), AADHAR (self-attested scanned copy of Aadhar Card) by sending a request to Registrar/Company at helpdeskdelhi@mcsregistrars.com or cs@shivamautotech.com respectively.

For Individual Demat shareholders – Please update your email id & mobile no. with your respective Depository Participant (DP) which is mandatory while e-Voting & joining virtual meetings through Depository.

C. INSTRUCTIONS FOR MEMBERS FOR ATTENDING THE AGM THROUGH VC / OAVM ARE AS UNDER:

- i. Members will be provided with a facility to attend the AGM through VC/OAVM by following the remote e-voting instructions mentioned above and selecting the EVSN for Company's AGM. The link for VC/OAVM will be available in shareholder/members login where the EVSN of Company will be displayed. Members who do not have the User ID and Password for e-voting or have forgotten the User ID and Password may retrieve the same by following the remote e-voting instructions mentioned in the Notice.
- ii. The facility of joining the AGM through VC / OAVM will be opened 15 minutes before the scheduled start-time of the AGM. The facility of participation at the AGM will be made available for 1000 members on first come first served basis. This will not include large Shareholders (Shareholders holding 2% or more shareholding), Promoters, Institutional Investors, Directors, Key Managerial Personnel, the Chairpersons of the Audit Committee, Nomination and Remuneration Committee and Stakeholders'

Relationship Committee, Statutory Auditors and Secretarial Auditors, who are allowed to attend the AGM without restriction on account of first come first served basis.

- iii. Members are encouraged to join the Meeting through Laptops / I-Pads for better sound and video clarity and experience.
- iv. Further members will be required to allow Camera and use Internet with a good speed to avoid any disturbance during the meeting.
- v. Please note that Participants Connecting from mobile devices or tablets or through laptop connecting via mobile hotspot may experience audio/video loss due to fluctuation in their respective network. It is therefore recommended to use Stable Wi-Fi or LAN Connection to mitigate any kind of aforesaid glitches.
- vi. Shareholders who would like to express their views/ask questions during the meeting with regard to the financial statements or any other matter to be placed at the 16th AGM may register themselves as a speaker by sending their request in advance by Thursday, September 23, 2021, mentioning their name, demat account number/folio number, email id, mobile number at Company's investor e-mail ID: cs@shivamautotech.com.
- vi. Those shareholders who have registered themselves as a speaker will only be allowed to express their views/ask questions during the meeting, depending upon the availability of time.

D. INSTRUCTIONS FOR SHAREHOLDERS FOR E-VOTING DURING THE AGM ARE AS UNDER:

- i. The procedure for e-voting on the day of the AGM is same as the instructions mentioned above for remote e-voting.
- ii. Only those shareholders, who are present in the AGM through VC/OAVM facility and have not casted their vote on the resolutions through remote e-voting and are otherwise not barred from doing so, shall be eligible to vote through e-voting system available during the AGM. The Members can opt for only one mode of voting i.e. remote e-Voting or e-Voting at the AGM. In case of voting by both the modes, vote cast through remote e-Voting will be considered final and e-Voting at the AGM will not be considered.
- iii. If any Votes are cast by the shareholders through the e-voting available during the

AGM and if the same shareholders have not participated in the meeting through VC/OAVM facility, then the votes cast by such shareholders shall be considered invalid as the facility of e-voting during the meeting is available only to the shareholders attending the meeting.

Note for Non-Individual Shareholders & Custodians:

- Non-Individual shareholders (i.e. other than Individuals, HUF, NRI etc.) and Custodians are required to log on to www.evotingindia.com and register themselves in the "Corporates" Module.
- A scanned copy of the Registration Form bearing the stamp and sign of the entity should be emailed to helpdesk.evoting@cdslindia.com.
- After receiving the login details, a compliance user should be created using the admin login and password. The Compliance user would be able to link the account(s) for which they wish to vote on.
- The list of accounts linked in the login should be mailed to helpdesk.evoting@cdslindia.com and on approval of the accounts they would be able to cast their vote.
- A scanned copy of the Board Resolution and Power of Attorney (POA) which they have issued in favour of the Custodian, if any, should be uploaded in PDF format in the system for the scrutinizer to verify the same.
- Alternatively Non Individual shareholders are required to send the relevant Board Resolution/ Authority letter etc. together with attested specimen signature of the duly authorized signatory who are authorized to vote, to the Scrutinizer at satyenderfcs@gmail.com and to the Company at cs@shivamautotech.com, if they have voted from individual tab & not uploaded same in the CDSL e-voting system for the scrutinizer to verify the same.

If you have any queries or issues regarding attending AGM & e-Voting at the CDSL e-Voting System, you may refer the Frequently Asked Questions (FAQs) and e-voting user manual for shareholders available under the help section at www.evotingindia.com, or you can write an email to helpdesk.evoting@cdslindia.com or contact at 022- 23058738 and 022-23058542/43.

All grievances connected with the facility for voting by electronic means may be addressed to:

**Mr. Rakesh Dalvi, Manager,
(CDSL) Central Depository Services (India) Limited,
A Wing, 25th Floor, Marathon Futurex,
Mafatlal Mill Compounds, N M Joshi Marg,
Lower Parel (East), Mumbai – 400013**
or send an email to helpdesk.evoting@cdslindia.com
or call 022-23058542/43

25. OTHER GUIDELINES FOR MEMBERS:

- i. The Members who have cast their vote by remote e-voting prior to the AGM may also attend/participate in the AGM through VC / OAVM but shall not be entitled to cast their vote again.
- ii. The voting rights of Members shall be in proportion to their shares in the paid-up equity share capital of the Company as on the cut-off date Wednesday, September 22, 2021. The members shall have one vote per equity share held by them. The facility of remote e-voting would be provided once for every Folio/ Client ID, irrespective of the number of joint holders.
- iii. In case of joint holders, the Member whose name appears as the first holder in the order of names as per the Register of Members of the Company will be entitled to vote at the AGM.
- iv. Any person, who acquires shares of the Company and becomes a Member of the Company after sending of the Notice and holding shares as of the cut-off date, shall follow the instructions mentioned above for remote e-voting and for joining the AGM.
- v. A person, whose name is recorded in the Register of Members or in the Register of Beneficial Owners maintained by the depositories as on the cut-off date only shall be entitled to avail the facility of remote e-Voting or casting vote through e-Voting system during the meeting.
- vi. The Board of Directors of the Company (the "Board") at its meeting held on August 13, 2021 have appointed Mr. Satyender Kumar, (Membership No. FCS 4087), Proprietor of

Satyender Kumar & Associates, Company Secretaries, Gurugram as the Scrutinizer to scrutinize the remote e-voting process and e-voting during the AGM in a fair and transparent manner in accordance with law and he has communicated his willingness to be appointed and will be available for the same purpose.

- vii. The scrutinizer shall immediately after the conclusion of e-voting at the Annual General Meeting, first download the votes cast during the AGM, and thereafter unblock the votes cast through remote e-voting and shall make a Consolidated Scrutinizer's Report of the total votes cast in favour or against, invalid votes, if any, and whether the resolution has been carried or not, and such report then shall be furnished to the Chairman of the Company or a person duly authorised by him within 48 hours of conclusion of the Annual General Meeting, who shall then countersign the same and declare the result of the voting forthwith.
- viii. The Results declared alongwith the Consolidated Scrutinizer's Report shall be placed on the Company's website www.shivamautotech.com and on the website of CDSL at www.evotingindia.com after the result is declared by the Chairman or a person duly authorised by him. The Company shall simultaneously forward the results to The National Stock Exchange of India Limited and The BSE Limited, where the shares of the Company are listed.
- ix. The scrutinizer's decision on the validity of e-voting shall be final and binding.

Place: Gurugram

Date: August 13, 2021

Registered Office:

10, 1st Floor, Tower A, Emaar Digital Greens,
Sector – 61, Golf Course Extension Road,
Gurugram, Haryana - 122102

CIN: L34300HR2005PLC081531

e-mail: info@shivamautotech.com

website: www.shivamautotech.com

Tel: +91 124 4698700 Fax: +91 124 4698798

**By Order of the Board of Directors
For Shivam Autotech Limited**

**Sd/-
Samta Bajaj
Company Secretary
Membership No. 50269**

ANNEXURE TO THE NOTICE

Explanatory Statement pursuant to Section 102 of the Companies Act, 2013.

ITEM NO. 3

Pursuant to the provisions of Section 149, 150, 152 and 161 and other applicable provisions of the Companies Act, 2013, Mr. Sunil Chinubhai Vakil, on the recommendation of Nomination and Remuneration Committee, was appointed by the Board of Directors as an Additional and Independent Director of the Company w.e.f. December 21, 2020 in order to fill the casual vacancy caused by the resignation of Mr. Sunil Kant Munjal, Independent Director, for a term of four years, not liable to retire by rotation, subject to the approval of Members at the 16th Annual General Meeting.

Mr. Sunil Chinubhai Vakil, a member of the Institute of Chartered Accountants of India has a 40+ years of experience in corporate finance/business consultancy with large corporate houses and a multinational company (10 years in aggregate) and 20+ years in independent practice in finance/corporate strategy areas. Major spheres of expertise are delineated hereunder.

❑ **Business Restructuring and Financial Engineering**

This is one of the major domains of consultancy over last 20+ years in which 50 odd companies' – *ranging from mid-size to large-size entities* – engagements involving restructuring/rehabilitation have been undertaken under CDR and erstwhile SICA. Currently, involved in several structuring RESOLUTION PLANS for Corporate borrowers through NCLT mechanism under the governing legislations - Companies Act and IBC Code.

❑ **Forensic Audit & Investigative Engagements**

Since year 2000, have been involved as a lead member of an elite group of Technical Advisors in ROTARY, undertaking Forensic Audit and Investigative Engagements to unearth and detect malpractices and financial irregularities in humanitarian service projects in various parts of the world like Philippines, Tanzania, Bangladesh, Kazakhstan, Sri Lanka and India involving millions of dollars of frauds and misdemeanors.

An accredited advisor to Central Bureau of Intelligence (CBI), a premier investigation agency in India on matters of national import involving economic crimes in cross border jurisdictions

❑ **Have been involved in representing Hunter Amenities' Indian Entity – as an independent director – to advise, counsel all legal and statutory**

compliances and contract drafting plus taxation and Foreign Exchange Regulation Management compliances.

- ❑ Have been involved with a number of public charitable institutions as trustees, & in sports bodies like BCCI and BCA as Finance Committee member.
- ❑ Was (for 2016-19), a Vice Chairperson of the International Committee of Technical advisors of ROTARY INTERNATIONAL that oversees, monitors and regulates the large, global grant-enabled humanitarian service projects in over 100+ countries around the world.
- ❑ Has been conferred with a "DISTINGUISHED SERVICE AWARD," the highest recognition bestowed to any individual Rotarian in recognition of *services rendered for humanitarian causes to community in need on a sustained basis* by The ROTARY FOUNDATION, which is a globally acclaimed voluntary organization

The requisite details of Mr. Sunil Chinubhai Vakil are provided in Annexure A to the Notice.

It is proposed that Mr. Sunil Chinubhai Vakil be appointed as an Independent Director of the Company for a term of four consecutive years i.e. from December 21, 2020 to December 20, 2024 and he shall not be liable to retire by rotation.

The Board considers that his association would be of immense benefit to the Company and it is desirable to avail services of Mr. Sunil Chinubhai Vakil as an Independent Director. Accordingly, the Board recommends the passing of resolution set out in Item No. 3 as an Ordinary Resolution for the approval of members.

In the opinion of the Board, he fulfils the conditions specified in the said Act and is independent of the management. The Company has received a declaration from Mr. Sunil Chinubhai Vakil confirming that he meets the criteria of independence as prescribed under Section 149(6) of the Companies Act, 2013 and Regulation 16(1)(b) of SEBI (Listing Obligations and Disclosure Requirements) Regulations, 2015. As per the circular of BSE Limited and National Stock Exchange of India Limited relating to the 'Enforcement of SEBI Orders regarding appointment of Directors by the listed companies dated June 20, 2018, Mr. Sunil Chinubhai Vakil is not debarred from holding the office of Director pursuant to any SEBI order or any other such statutory authority.

Except Mr. Sunil Chinubhai Vakil, none of the Directors and Key Managerial Personnel of the Company or their relatives are in anyway concerned or interested, in the Ordinary Resolution as set out at Item No. 3.

ITEM NO. 4

The present proposal is to seek the Members' approval for the re-appointment of Mr. Neeraj Munjal as Managing Director of the Company designated as "Executive Director" for a further period of 5 years on the existing remuneration, in terms of the applicable provisions of the Companies Act, 2013 & rules made thereunder and SEBI (Listing Obligations and Disclosure Requirements) Regulations, 2015.

Mr. Neeraj Munjal has been responsible for conceptualizing near net shape forging technology in Shivam Autotech Limited employing cold, warm and hot forging and commissioned its first unit at Binola, Gurugram in 1999. He has been spearheading the operations of the company and successfully handles its operations which have brought the company to this level. The company currently has four of its units at different locations in the country. He brings with himself 25 years of rich experience in auto-component sector.

Mr. Neeraj Munjal specializes in Business Management from Bradford College, England, besides a Bachelor's Degree in Commerce. With his vast experience of precision and value engineering, he is proficient to lead a team of engineers to evolve solution to complex manufacturing problems. He also held Chairmanship of CII, Haryana Chapter.

Mr. Neeraj Munjal was appointed as the Managing Director of the Company by the members for a period of five years to hold office upto March 31, 2021. Keeping in view that Mr. Neeraj Munjal has rich and varied experience in the Industry and has been involved in the operations of the Company over a long period of time, it would be in the interest of the Company to consider and continue the employment of Mr. Neeraj Munjal as Managing Director of the Company.

In terms of the Corporate Governance Guidelines of the Company and pursuant to the recommendation of the Nomination and Remuneration Committee, the Board of Directors of the Company, passed a resolution on June 09, 2021 approving re-appointment of Mr. Neeraj Munjal, as Managing Director of the Company for a further period of five years with effect from April 01, 2021 to March 31, 2026. This is subject to the approval of the shareholders at this Annual General Meeting.

The Company has received requisite disclosures/declaration from Mr. Neeraj Munjal for being appointed as Director of the Company. As per the circular of BSE Limited and National Stock Exchange of India Limited relating to the 'Enforcement of SEBI Orders regarding appointment of Directors by the listed companies dated June 20, 2018, Mr. Neeraj Munjal is not debarred from holding the office

of Director pursuant to any SEBI order or any other such statutory authority.

The existing remuneration of Mr. Neeraj Munjal is set out as under:

- A. **Basic Salary:** Rs. 8,00,000/- (Rupees Eight Lacs only) per month.
- B. **Commission:** He will also be entitled to commission in addition to Basic Salary, Perquisites and any other Allowances, benefits or amenities subject to the condition that the amount of commission shall not exceed 2.00% of the Net Profit of the Company in a particular financial year as computed in the manner referred to in Section 197 of the Companies Act, 2013.
- C. **Perquisites and Allowances:** In addition to the above Basic Salary and Commission, he shall be entitled to the following monthly perquisites and allowances:
 - a) **Allowances**
 - House Rent Allowance 50.00% of Basic Pay
 - Electricity Allowance 10.00% of Basic Pay
 - Professional Development Allowance 10.00% of Basic Pay
 - Child Education Allowance 5.00% of Basic Pay
 - Furnishing Allowance 5.00% of Basic Pay
 - Management Allowance 3.40% of Basic Pay
 - b) **Perquisites:** The Managing Director shall also be entitled to the following perquisites:
 - i. Club Fees: Reimbursement of Actual Fees of Clubs.
 - ii. Personal Accident Insurance: Actual premium to be paid by the Company.
 - iii. Medical Reimbursement: Reimbursement of actual medical insurance premium and medical expenses incurred by him and his family.
 - iv. Insurance of Household goods: Actual premium to be paid by the Company.
 - v. Car: Facility of cars with drivers to be used for the business of the Company shall not be included in the computation of the ceiling of perquisites.
 - vi. Telephone: Free telephone facility at residence including Mobile Phone to be used for the business of the Company shall not be included in the computation of the ceiling of perquisites.
 - vii. Leave: One month's leave with full salary for every 11 months of service subject to the condition that leave accumulated but not availed will be encashed.

- viii. Reimbursement of expenses: Reimbursement of entertainment, travelling, hotel and other expenses actually and properly incurred by him in India and abroad for the business of the Company.
- ix. Contribution to Provident Fund, Super Annuation or Annuity Fund etc.: Company's Contribution to Provident Fund, Super Annuation or Annuity Fund etc. will be as per policy/rules of the Company to the extent these either singly or put together are not taxable under the Income Tax Act.
- x. Gratuity: Gratuity payable at a rate not exceeding half a month's salary for each completed year of service.
- xi. Leave Travel Concession: For the Managing Director and his family once in a year incurred in accordance with the policy/rules of the Company.
- xii. Spouse Travelling Expenses: Such traveling expenses of the spouse as may be required in connection with the business of the Company.
- xiii. Other allowances: As may be applicable from time to time as per policy/rules of the Company.

For the purpose of calculating the above ceiling, perquisites shall be evaluated as per Income Tax Rules, wherever applicable. In the absence of any such rules, perquisites shall be evaluated at actual cost.

For the aforesaid purpose "Family" means the dependent children and dependent parents of the Managing Director.

- D. **Minimum Remuneration:** In any financial year during the currency of tenure of the Managing Director, the Company has no profits or its profits are inadequate, the minimum remuneration payable to the Managing Director shall be substantive salary and perquisites as mentioned above, subject to the ceiling set out under

Section II of Part II of Schedule V to the Companies Act, 2013 for a period of three years effective from April 01, 2021 till March 31, 2024.

However, he shall not be entitled to any sitting fee for attending meetings of the Board or Committee thereof.

Explanation: For the aforesaid purposes "Family" means the spouse and the dependent children.

Provided further that the following perquisites which are also allowed to the Managing Director shall not be included in the computation of ceiling as specified in (D) above:

- (i) Contribution to Provident Fund, Super Annuation Fund or Annuity Fund to the extent these either singly or put together are not taxable under Income Tax Act, 1961; and
- (ii) Gratuity payable at a rate not exceeding half month's salary for each completed year of service.
- (iii) encashment of leave at the end of the tenure.

The terms of appointment and remuneration including minimum remuneration as detailed in the resolution read with Explanatory Statement may be regarded as an abstract of the terms of Appointment and Memorandum of Interest under section 190 of the Act.

In compliance with the provisions of Secretarial Standard 2 and SEBI Listing Regulations, the details of the director are attached with the notice as Annexure A.

Except Mr. Neeraj Munjal & Mrs. Charu Munjal, being spouse of Mr. Neeraj Munjal, none of the directors, Key Managerial Personnel (KMPs) and their relatives are concerned / interested either financially or otherwise in this Resolution.

As at date of this notice, Mr. Neeraj Munjal does not hold any shares in the Company. Information as required under Schedule V of the Companies Act, 2013 is enclosed as Annexure B.

The resolution is accordingly recommended for the approval of the Members as Special resolution.

ANNEXURE – A

INFORMATION ON DIRECTORS SEEKING APPOINTMENT/RE-APPOINTMENT AT THE FORTHCOMING ANNUAL GENERAL MEETING

Name of Director	Dr. Anil Kumar Gupta	Mr. Sunil Chinubhai Vakil
DIN	02643623	02527630
Date of Birth & Age	02-April-1951 70 years	06-May-1956 65 years
Date of first Appointment on the Board	09-August-2019	21-December-2020
Qualification	Doctorate in Engineering and Fellow of Indian National Academy of Engineering (FNAE).	Fellow Member of the Institute of Chartered Accountants of India
Experience in Specific functional areas	Creating value addition and complex sub-systems / systems. In-depth knowledge of metallurgical engineering.	40+ years of experience in corporate finance/business consultancy with large corporate houses and a multinational company (10 years in aggregate) and 20+ years in independent practice in finance/corporate strategy areas.
Remuneration proposed to be paid	NIL	NIL
No. of years of Experience	49 years	43 years
Terms and Conditions of appointment/re-appointment	<p>He was appointed as a Non-Executive Director w.e.f. from August 9, 2019 for a term of 5 years, liable to retire by rotation. He has served as a Whole-Time Director of the Company and resigned as a Whole Time Director w.e.f. August 8, 2019.</p> <p>Non - executive Directors do not draw any remuneration from the Company except Sitting Fee for attending the meetings of Board of Directors and Committees thereof.</p> <p>The other terms and conditions are available at www.shivamautotech.com</p>	<p>He is being appointed as an Independent Director w.e.f. from December 21, 2020 for a term of 4 years, not liable to retire by rotation.</p> <p>Non - executive Directors do not draw any remuneration from the Company except Sitting Fee for attending the meetings of Board of Directors and Committees thereof and the commission based on the net profits of the Company within the maximum limits as set under the Companies Act, 2013, and rules made thereunder.</p> <p>The other terms and conditions are available at www.shivamautotech.com</p>
Relationship with other Directors/ Key managerial Personnel (if any)	None	None
List of Companies in which outside Directorship held	Akar Auto Industries Limited	1. Woleco India Private Limited 2. Gujarat Metal Cast Industries Private Limited 3. Amitysoft Technologies Private Limited
Board Membership of Listed Companies as on March 31, 2021	1. Akar Auto Industries Limited 2. Shivam Autotech Limited	Shivam Autotech Limited
Chairman / Member of Committees of Board of directors of other companies in which he/she is a director*	-	-
No. of Board Meetings attended during the year	Details mentioned in the Corporate Governance Report	Details mentioned in the Corporate Governance Report
No of Shares held	NIL	NIL

Name of Director	Mr. Neeraj Munjal
DIN	00037792
Date of Birth & Age	01-Jul-1967 54 years
Date of first Appointment on the Board	29-Jul-2005
Qualification	Bachelor's Degree in Commerce and specializes in Business Management from Bradford College, England.
Experience in Specific functional areas	He has a vast experience of precision and value engineering, and Project Management, Global Business Leadership, Business Development and Business Operations. He has been responsible for conceptualizing near net shape forging technology in Shivam Autotech Limited employing cold, warm and hot forging.
Remuneration proposed to be paid	Provided in Explanatory Statement of the Notice
No. of years of Experience	32 years
Terms and Conditions of appointment/re-appointment	He was re-appointed as the Managing Director of the Company w.e.f. from April 01, 2021 for a term of 5 years, liable to retire by rotation. As per Nomination and Remuneration Policy of the Company as displayed on the Company's website www.shivamautotech.com . Details of the remuneration drawn is mentioned in the Corporate Governance Report.
Relationship with other Directors/Key managerial Personnel (if any)	Spouse of Mrs. Charu Munjal, Whole-Time Director of the Company
List of Companies in which outside Directorship held	Dayanand Munjal Investments Private Limited
Board Membership of Listed Companies as on March 31, 2021	Shivam Autotech Limited
Chairman / Member of Committees of Board of directors of other companies in which he/she is a director*	-
No. of Board Meetings attended during the year	Details mentioned in the Corporate Governance Report
No of Shares held	NIL

*Only Audit Committee & Stakeholders' Relationship Committee considered

ANNEXURE – B

INFORMATION AS REQUIRED UNDER SCHEDULE V OF THE COMPANIES ACT, 2013

I. GENERAL INFORMATION

S.No.	Particular/Subject	Information
1.	Nature of industry	Manufacturer of Auto Components
2.	Date or expected date of commencement of commercial Production	Year 2005
3.	In case of new companies, expected date of commencement of activities as per project approved by financial institutions appearing in the prospectus	NA
4.	Financial performance based on given indicators	In the Financial Year 2020-21, the Company made a turnover of Rs. 48,741.15 lakhs and a loss of Rs. 2,252.56 lakhs after tax
5.	Foreign Investments or collaborators, if any	NIL

II. INFORMATION ABOUT THE APPOINTEE

S.No.	Particular/Subject	Mr. Neeraj Munjal
1.	Background Details	He specializes in Business Management from Bradford College, England, besides a Bachelor's Degree in Commerce. With his vast experience of precision and value engineering, he is proficient to lead a team of engineers to evolve solution to complex manufacturing problems
2.	Past remuneration	For the period from 01 April 2020 to 31 March 2021, Mr. Neeraj Munjal has drawn a remuneration of Rs.176.06 Lakhs
3.	Recognition or awards	He has been responsible for conceptualizing near net shape forging technology in Shivam Autotech Limited employing cold, warm and hot forging.
4.	Job profile and his suitability	He is working as a Managing Director of the Company.
5.	Remuneration proposed	Salary, other perquisites and other terms as fully set out in the explanatory statement of item no. 04 of the Notice and as per Schedule V of the Companies Act, 2013 in case of no profits/inadequate profits pursuant to the approval of the shareholders.
6.	Comparative remuneration profile with respect to industry, size of the company, profile of the position and person	Keeping in view that Mr. Neeraj Munjal has rich and varied experience in the Industry and has been involved in the operations of the Company over a long period of time and further considering the size of the Company and responsibilities shouldered by him of the business activities of the Company, proposed remuneration is sought to be paid as appropriate remuneration and is commensurate with industry standards and Board level positions held in similar sized and similarly positioned businesses.
7.	Pecuniary relationship directly or indirectly with the Company personnel, if any	Mr. Neeraj Munjal does not have any pecuniary relationship with the Company other than the remuneration he received as Executive Director of the Company and he is not related to any director/ managerial personnel except Mrs. Charu Munjal, Whole-time Director of the Company.

III. OTHER INFORMATION

S.No.	Particular/Subject	Information
1.	Reason of loss or inadequate profits	Considerable slowdown in auto sector and COVID-19 Pandemic which have posed unprecedented challenges to the business operations of the Company due to the disruption caused by lockdowns and restriction on movement of vehicles and people.
2.	Steps taken or proposed to be taken for improvement	<p>Against the bleak global and Indian outlook, the Company has adopted a cautious approach.</p> <ol style="list-style-type: none"> 1. The Company is cutting down on all avoidable costs and focusing on the good costs. Company also took some Cost saving measures such as merging the Manesar plant with Rohtak plant for operational synergies and cost reductions and optimization of manpower cost by reductions in manpower gradually in non-productive areas. 2. Company has undertaken infusion of Rs.35 crore in 2020-21, which has already been brought in to ramp up operations demonstrating the commitment and confidence of the Promoters for the revival of the Company. 3. The Company has been able to increase the liquidity in the system by availing ECLGS facility under the Emergency Credit Line Guarantee Scheme issued by the Government of India.
3.	Expected increase in the productivity and profits in measurable terms	In-line with the above steps taken by the Company, the operations have started to show improvements and the Company has been able to ramp up its productions to utilization of above 80%. The Company has achieved EBITDA of Rs. 8,103.24 Lacs in FY21 as against EBITDA of Rs. 5,263.27 Lacs in FY20. The Company expects that productivity and profitability may improve and would be comparable with the industry average.

Place: Gurugram**Date: August 13, 2021****Registered Office:**

10, 1st Floor, Tower A, Emaar Digital Greens,
Sector – 61, Golf Course Extension Road,
Gurugram, Haryana - 122102
CIN: L34300HR2005PLC081531
e-mail: info@shivamautotech.com
website: www.shivamautotech.com
Tel: +91 124 4698700 Fax: +91 124 4698798

**By Order of the Board of Directors
For Shivam Autotech Limited**

**Sd/-
Samta Bajaj
Company Secretary
Membership No. 50269**

BOARD'S

REPORT

Dear Members,

Your Directors are pleased to present before you, the 16th Annual Report on the business and operations of the Company together with the Audited Financial Statements of the Company for the Financial Year ended March 31, 2021.

Financial Highlights

The Company's financial performance, for the year ended March 31, 2021 is summarized below:

Rupees (in Lacs)

Particulars	For the year ended	
	March 31, 2021	March 31, 2020
Gross Sales & Other Income	49,092.82	58,887.69
Profit/(Loss) before Depreciation and Interest	8,103.24	5,263.37
Depreciation	4,872.28	5,381.24
Interest	5,683.56	5,306.36
Profit/(Loss) before Taxation	(2,452.60)	(5,424.23)
Provision for Taxation (Deferred & Current)	(200.04)	(1,710.79)
Profit/(Loss) after Taxation	(2,252.56)	(3,713.44)

State of Company's Affairs and Future Outlook

During the financial year 2020-21, revenue from operations was Rs. 48,741.15 lacs as compared to Rs. 58,783.25 lacs in 2019-20, registering a decrease of 17.08%.

The year under review had two distinct themes, the first half of the year saw the impact of COVID-19 induced lockdowns wiping out majority of the first quarter of the fiscal and the second half of the year showed some recovery in automobile production, leading to growth in sales. While

the sales saw a rebound in the second half of the fiscal, it was not enough to cover the loss of the first half of the year. Its crippling effect on the Indian economy is still reverberating.

The automobile sector in India was already facing challenges pre-COVID times due to the transition of automobile emission norms related issues' compliance effective from April 01, 2020. Resultant cost increases are not yet fully transcended into the pricing of automotive products. Besides the overall slowdown in Economy from pre-pandemic period has caused entire Automobile Industry to face very challenging times in last few years.

Despite the challenges posed by the pandemic, the Company adapted to the changing business needs. The state of preparedness and quick countermeasures taken by the Company had started to show some improvements in the second half of FY 2020-21. **Before interest, depreciation and taxes, the Company has achieved operational profit of Rs. 8,103.24 Lacs increased by 53.96% in year 2020-21 over Rs. 5,263.27 Lacs in 2019-20.**

The Company remains cautiously optimistic about growth in the next financial year, as a credible recovery in the Indian economy and a positive momentum towards personal mobility is likely to further strengthen the demand for two-wheelers. The wide range of best-in-class products and consistent alignment of new technologies and services will also ensure Company's efforts towards achieving growth impetus.

Further, the Company is constantly working on new business models and aims to go beyond the automotive sector.

Business Overview

With the state of art manufacturing facilities, the Company is functioning successively to strengthen its Customer Base. By expanding the customer base, the company is de-risking the dependence on single customer. Four different plants in various parts of the country will enable company to cater its customer through PAN India basis.

For the last couple of years, the Company has been widening its customer base with every modern facilities across its four plants. Quite a few top class Indian and International Companies, are now customers and the list is growing. In coming years, the Company will be able to consolidate its business further.

Awards and Recognition

In its constant quest for growth and excellence, the Company is proud recipient of the following recognition as listed below during the year -

1. The Company has successfully achieved the Green Building Standards for Gold Level of Certification under the Indian Green Building Council (IGBC) Green Factory Buildings Rating System for its Rohtak and Kolar Plant in April 2021 and June 2021 respectively.

Transfer to General Reserve

During the year under review, the Company has not transferred any amount to General Reserves. The closing balance amount of Reserves and Surplus of Rs. 9,302.14 Lacs (Previous year Rs. 11,516.73 Lacs) will be retained as surplus in the Statement of Profit and Loss.

Consolidation of Manufacturing Operations of Manesar Plant

During the Financial Year 2020-21, the Company has closed the manufacturing operations which was only a small feeder operations facility at its plant situated at Plot No.1, Sector 5, IMT Manesar Gurugram, Haryana-122050 This has helped to consolidate the operations by relocating the machinery and transferring the production to Company's fully integrated plant situated at Plot No. 9, Sector 30A, IMT Rohtak District Rohtak, Haryana-124001. There is no impact on overall operational capacities in the company.

Further the Company is pursuing an ongoing enhancement in its manufacturing margins due to more efficient production processes and elimination of duplicated overheads and thus, the said closure of manufacturing facilities does not have any material and adverse effect on operations and production of the Company, thereby providing benefit to the Company and employees and good for overall system economy, ecology and customers.

Dividend

Considering the state of economy and industry, the Board of Directors have not recommended any dividend for the financial year 2020-21.

The Register of Members and Share Transfer Books shall remain closed from Monday, September 20, 2021 to Wednesday, September 29, 2021 (both days inclusive).

Holding Company

The promoters of the Company i.e. Dayanand Munjal Investments Private Limited (DMIPL) hold 74,795,950 equity shares of Rs. 2/- each which represents 74.80% of the paid up equity capital of the Company.

Your company continues to be a subsidiary company of DMIPL.

Subsidiary Companies, Joint Ventures or Associate Companies

The Company neither has any subsidiaries, joint ventures or associate companies nor any company have become or ceased to be its subsidiaries, joint ventures or associate companies during the year under review.

Management Discussion and Analysis report

A detailed discussion on the business performance and future outlook forms part of Management Discussion and Analysis Report, which is separately attached as **Annexure A** to this Board's Report.

Board of Directors

a) Meeting of Board of Directors

A calendar of Meetings is prepared and circulated in advance to the Directors. During the Financial Year 2020-21, 8 meetings of the Board of Directors of the Company were held on June 10, 2020, July 28, 2020, August 31, 2020, September 25, 2020, November 09, 2020, December 03, 2020, December 21, 2020 and February 12, 2021. The intervening gap between the meetings was within the period prescribed under the Companies Act, 2013 read with MCA General Circular No. 11/2020 dated March 24, 2020 and Securities and Exchange Board of India (Listing Obligations and Disclosure Requirements) Regulations, 2015

(hereinafter referred to as “SEBI Listing Regulations”) read with SEBI Circular SEBI/HO/CFD/CMD1/CIR/P/2020/3 dated March 19, 2020 & SEBI/HO/CFD/CMD1/CIR/P/2020/110 dated June 26, 2020. For details of the meetings of the Board, please refer to the Corporate Governance Report, which forms part of this Annual Report.

b) Appointment/re-appointment of Directors

Dr. Anil Kumar Gupta, (DIN: 02643623) Non-Executive Director of the Company, retire by rotation at the ensuing Annual General Meeting and being eligible, offer himself for re-appointment. A resolution seeking shareholders’ approval for his re-appointment forms part of the Notice.

Based on the recommendation of the Nomination and Remuneration Committee, your Company has appointed Mr. Sunil Chinubhai Vakil (DIN: 02527630) as an Additional Director of the Company in the category of Non-Executive and Independent Director considering his integrity, expertise and experience effective December 21, 2020 for a period of four years in order to fill the casual vacancy caused by the resignation of Mr. Sunil Kant Munjal, Independent Director, subject to the approval of shareholders at the 16th AGM. The notice convening the meeting sets out the details of his appointment.

Further, based on the recommendation of the Nomination and Remuneration Committee, your Company has re-appointed Mr. Neeraj Munjal (DIN: 00037792) as Managing Director of the Company in the category of Executive Director considering his rich and varied experience in the automobile industry effective April 01, 2021 for a period of five years, subject to the approval of shareholders at the 16th AGM. The notice convening the meeting sets out the details of his re-appointment.

c) Changes in Directors and Key Managerial Personnel

During the year under review and between the end of the Financial Year and date of this report, the following are the changes in Directors and Key Managerial Personnel of the Company:

- i. During the year under review, Mr. Dinesh Kumar Mishra (AGM-Finance), being one level below the directors who was in whole-time employment, has resigned from the position of whole-time Key Managerial Personnel of the Company with effect from September 02, 2020.
- ii. During the year under review, Mr. Sunil Kant Munjal (DIN: 00003902), Chairman & Independent Director has resigned from the directorship with effect from September 24, 2020. The Board placed on record its appreciation for his invaluable contribution, guidance & support during his tenure with the company.
- iii. Ms. Jyothi Prasad (DIN: 06947488) was appointed as Non- Executive & Independent Director of the Company w.e.f. November 13, 2019 and her appointment as Non-Executive & Independent Director was approved at the 15th Annual General Meeting (AGM) held on September 30, 2020.
- iv. Mr. Bhagwan Dass Narang (DIN: 00826573), Non-Executive and Independent Director, has been appointed as the Chairman of the Company by the Board of Directors at its meeting held on November 09, 2020.
- v. Mr. Sunil Chinubhai Vakil (DIN: 02527630) is appointed as Additional (Non-Executive and Independent) Director of the Company w.e.f. December 21, 2020. The Board recommends the appointment of Mr. Sunil Chinubhai Vakil as Non-Executive and Independent Director, not liable to retire by rotation, and to hold office for a first term of 4 consecutive years with effect from December 21, 2020 to December 20, 2024 pursuant to Section 149, 152 & 161 of the Act read with rules made thereunder.
- vi. The Board has recommended for re-appointment of Mr. Neeraj Munjal (DIN: 00037792) as Managing Director of the Company, liable to retire by rotation and to hold office for a period of 5 years with effect from April 01, 2021 upto March 31, 2026 pursuant to the provisions of Section 196, 197, 198 & 203 read with Schedule V of the Act read with rules made thereunder.
- vii. Mr. Davendra Ujlayan (PAN AAFPU2249C) Chief Financial Officer of the Company has retired upon his attaining the age of superannuation with effect from the close of business hours of July 08, 2021 and consequently ceases to be the Chief Financial Officer and Key Managerial Personnel of the Company. The Board placed on record its appreciation for his invaluable contribution, guidance & support during his tenure with the Company.

The Company has received notice in writing, from Mr. Sunil Chinubhai Vakil under Section 160 of the Companies Act, 2013 proposing his own candidature as Director of the Company.

None of the aforesaid Directors are disqualified under Section 164(2) of the Companies Act 2013. Further, they are not debarred from holding the office of Director pursuant to order of SEBI or any other authority as required under the Circular dated 20th June, 2018 issued by The BSE Limited and The National Stock Exchange of India Limited.

Brief resume and other details of directors who is proposed to be appointed/re-appointed as a Director of your Company, have been furnished in the Explanatory Statement to the Notice of the ensuing Annual General Meeting.

The appointment/re-appointments form part of the Notice of the sixteenth Annual General Meeting and the relevant resolutions are recommended for your approval.

Key Managerial Personnel

Mr. Neeraj Munjal (DIN: 00037792), Managing Director & CEO, Mr. Davendra Ujlayan,* Chief Financial Officer, and Ms. Samta Bajaj, Company Secretary & Compliance Officer are the Key Managerial Personnel of your Company in accordance with the provisions of Section 2(51) and 203 of the Companies Act, 2013 read with Companies (Appointment and Remuneration of Managerial Personnel) Rules, 2014 as on March 31, 2021.

d) Committees of the Board

The Company has several Committees which have been established in compliance with the requirement of the relevant provisions of applicable laws and statutes. As on March 31, 2021, the Board has three committees: The Audit Committee, Nomination and Remuneration Committee and Stakeholders' Relationship Committee. A detailed note on the composition of the Board and its committees is provided in the Corporate Governance Report, which forms integral part of the Board's Report.

e) Declaration by Independent Director

The Company has received necessary declaration from all Independent Directors under Section 149 (7) of the Companies Act, 2013 and Regulation 25(8) of SEBI Listing Regulations that they meet the criteria

of Independence laid down in Section 149(6) of Companies Act, 2013 and Regulation 16(1) (b) of SEBI Listing Regulations.

In the opinion of the Board, Independent Directors fulfil the conditions specified in the Act, Rules made thereunder and SEBI Listing Regulations and are independent of the management.

f) Board Evaluation

Pursuant to the provisions of the Companies Act, 2013 and the Corporate Governance requirements as prescribed by Securities and Exchange Board of India ("SEBI") under the SEBI Listing Regulations, the Board is required to carry out an Annual Performance Evaluation of its own, Board's committees and Individual Directors on the criteria as recommended by the Nomination and Remuneration Committee of the Company.

The performance of the Board as a whole, its Committee(s) and Individual Directors including the Chairman of the Board, was evaluated by a questionnaire formulated by the Company.

The questionnaire was formulated based on the following criteria:

- The Board composition and structure,
- Effectiveness of board processes,
- Information and functioning, Knowledge & Skill
- Personal Attributes,
- The composition of committees,
- Effectiveness of committee meetings,
- The contribution of the individual director to the Board and committee meetings,
- Preparedness of Directors on the issues to be discussed,
- Meaningful and constructive contribution of Directors and their inputs in meetings.

As part of the evaluation process, the performance of Non-Independent Directors, the Chairman and the Board as a whole was conducted by the Independent Directors. The performance evaluation of the respective Committees and that of the Independent Directors was done by the Board excluding the Director being evaluated. The performance evaluation was found satisfactory.

*Retired w.e.f. July 08, 2021

g) Separate Meeting of Independent Directors

In terms of requirements under Schedule IV of the Companies Act 2013 and SEBI Listing Regulations, a separate meeting of Independent Directors was held on February 12, 2021. In a separate meeting of Independent Directors, performance of Non-Independent Directors, performance of the board as a whole and performance of the Chairman was evaluated, taking into account the views of executive directors and non-executive directors.

h) Policy on Directors' remuneration and other details

The Company's policy on Directors' remuneration and other matters provided in Section 178(3) of the Act has been disclosed in the Corporate Governance Report, which forms part of the Board's report.

Statutory Auditors and Auditor's Report

NSBP & Co., Chartered Accountants, New Delhi (Firm Registration no. 001075N) were appointed as the Statutory Auditors of the Company in the 12th AGM held on September 29, 2017 for a term of five years as per the provisions of Section 139 of the Companies Act, 2013 read with Companies (Audit and Auditors) Rules, 2014, who will hold the office upto the conclusion of the 17th Annual General Meeting. They have furnished a certificate confirming that they are not disqualified from continuing as Auditors of the Company.

The Report given by the Auditors, NSBP & Co., Chartered Accountants, New Delhi, on the financial statements of the Company for the financial year 2020-21, is part of the Annual Report.

Explanation to Auditors' Remarks

The observations & remarks of Statutory Auditors in their Report on the financial statements of the Company for the financial year 2020-21 read with relevant Notes to Accounts are self-explanatory and therefore, do not require further explanation. Further, with regard to section 134(3)(ca) of the Companies Act, 2013, no frauds have been reported by the Auditors under section 143(12) of the said Act.

Share Capital

During the year under review, the Issued, Subscribed and Paid-up Equity Share Capital as on March 31, 2021 was 10 Crores shares of Rs. 2/- each amounting to Rs. 20 Crore.

a) Your Company has not issued shares with differential voting rights nor granted employee stock options nor sweat equity. And also the Company has not accepted or repaid any debentures, preference share capital and any bond & security during the financial year, and none of the Directors of the Company hold any shares or security of the Company. The Company does not have any Debentures, Preferential Shares as on March 31, 2021.

b) Your company has not made any provisions of money for purchase of its own shares by employees or by trustees for the benefit of employees during the year under review.

Deposits

During the year, the Company has not accepted any fixed deposit.

Finance

Cash and cash equivalent as at March 31, 2021 was Rs. 5,327.34 lakhs. The Company continues to focus on judicious management of its working capital. Receivables, inventories and other working capital parameters were kept under strict check through continuous monitoring.

Transfer to Investor Education and Protection Fund

During the Financial Year under review, your Company has transferred unpaid/ unclaimed dividend, amounting to Rs. 7,74,968/- for financial Year 2012-13 to the Investor Education and Protection Fund (IEPF) of the Central Government of India.

Secretarial Auditor and Secretarial Audit & Compliance Report

Pursuant to the provisions of Section 204 of the Companies Act, 2013 and the Companies (Appointment and Remuneration of Managerial Personnel) Rules, 2014, the Company has appointed M/s. Satyender Kumar & Associates, a proprietorship firm of Company Secretaries to undertake the Secretarial Audit of the Company for the financial year 2020-21. Secretarial Audit Report in prescribed format MR-3 are annexed as **Annexure – D** to this Board's Report.

Further, pursuant to SEBI Circular CIR/CFD/CMD1/27/2019 dated February 08, 2019, the Company has obtained Secretarial Compliance Report from Practising Company Secretary on compliance of all applicable SEBI (Listing Obligations and Disclosure Requirements), Regulations 2015 and circulars/guidelines issued thereunder and the copy of the same has been submitted with the Stock exchanges within the prescribed due date.

The Board has re-appointed M/s Satyender Kumar & Associates, Company Secretary (COP No. 5189) as the Secretarial Auditor of the Company for the financial year 2021-22. Your Company had received their written consent that the appointment will be in accordance with the applicable provisions of the Companies Act, 2013 and rules framed thereunder.

Explanation to Secretarial Audit Report

The Secretarial Audit Report is self-explanatory and do not call for any further comments. There are no qualifications, reservation, adverse remark, observations, comments or disclaimer given by the Auditor in his Report except one remark that:

“During the period under review the Company has complied with the provisions of the Act, Rules, Regulations, Guidelines, Standards, etc. mentioned above except that the company has obtained loan from holding company (74.8% shares) with an option of conversion of such loan into shares, without the prior approval of members as required under Section 62(3) of the Act.”

Audit Committee

The Audit Committee comprises mainly of Independent Directors and the composition is as under:

Ms. Jyothi Prasad ¹	:	Chairperson
Mr. Bhagwan Dass Narang	:	Member
Dr. Anil Kumar Gupta	:	Member
Mr. Sunil Chinubhai Vakil ²	:	Member

The terms of reference of the Audit Committee are wide enough to cover the matters specified for the Audit Committee under SEBI Listing Regulations as well as Section 177 of the Companies Act, 2013; the detailed terms of reference are as mentioned in the **Annexure B** to this Board Report.

During the year under review, the Board has accepted all recommendation of Audit Committee and accordingly no disclosure is required to be made in respect of non-acceptance of the recommendation of the Audit Committee by the Board.

Nomination and Remuneration Committee

The Nomination and Remuneration Committee (NRC) has been constituted according to Section 178(5) of the Companies Act, 2013 and the composition is as under:

Ms. Jyothi Prasad ³	:	Chairperson
Mr. Bhagwan Dass Narang	:	Member
Dr. Anil Kumar Gupta	:	Member
Mr. Sunil Chinubhai Vakil ⁴	:	Member

The detailed terms of reference are as mentioned in the **Annexure B** to this Board's Report.

Nomination and Remuneration Policy and Remuneration to the Directors

The Board on the recommendation of the Nomination & Remuneration Committee has framed a policy for selection and appointment of Directors, Senior Management Personnel including Key Management Personnel and affixing their remuneration.

The Nomination and Remuneration Policy of the Company is designed to attract, motivate, improve productivity and retain manpower by creating a congenial work environment, encouraging initiatives, personal growth, team work and inculcating a sense of belongingness and involvement, besides offering appropriate remuneration packages and superannuation benefits. The salient features of the Nomination and Remuneration Policy and the details of remuneration under Section 197 of the Companies Act, 2013 paid to Directors are provided in Corporate Governance Report which forms integral part of this Report.

Corporate Social Responsibility (CSR) Committee

Pursuant to Rule 3(2) of The Companies (Corporate Social Responsibility Policy) Rules, 2014, the Corporate Social Responsibility Committee of the Board has been dissolved but the company is still committed in contributing towards various social projects and institutions for the welfare and betterment of society. Thus, the existing members of the Corporate Social Responsibility Committee are hereby relieved from their duties of the Committee.

Further the details of the same are mentioned in the **Annexure B** to this Board's Report.

Business Risk Management

The Company has in place a robust risk management framework that identifies and evaluates business risks and opportunities. The Company recognises that these risks need to be handled effectively and mitigated to protect the interests of the shareholders and stakeholders, to achieve business objectives and create sustainable value and growth. The Company's risk management processes focus on ensuring that these risks are promptly identified and a mitigation action plan is developed and monitored periodically to ensure that the risks are being addressed accordingly. The Company's risk management framework operates with the following objectives:

- Proactively identify and highlight risks to the right stakeholders
- Facilitate discussions around risk prioritisation and mitigation
- Provide a framework to assess risk capacity and appetite;
- develop systems to warn when the appetite is getting breached

Last year, the lockdown imposed significant hardships on the entire human race and tested their survival. Many businesses were forced to adopt varied cost cutting measures. However, your Company ensured investments

¹ Appointed as the Chairperson of the committee w.e.f. November 09, 2020

² Appointed as the member of the committee w.e.f. February 12, 2021.

³ Appointed as the Chairperson of the committee w.e.f. November 09, 2020

⁴ Appointed as the member of the committee w.e.f. February 12, 2021.

on employee well-being measures. Your Company came up with a comprehensive risk mitigation plan and a dedicated team to manage Covid-19 risk. Some of the risk mitigation steps were:

- a. frequent interactions with dealers, suppliers, investors so that the ecosystem remained motivated;
- b. proactive announcement of Work from Home policy, and an increased hygiene level at the workplace;
- c. manufacturing at all the plants was proactively suspended, however with preparedness to restart at a short notice;
- d. multiple communications sent to employees on end user awareness due to increased risk of cyber-attacks.

With a multi-sourcing strategy plan, your Company was able to successfully manage this risk.

Further the Board has also identified the following risks:

Over dependence on few customer base, imposition of strict environmental / safety / regulatory regulations intensifying competition, declining margins, increase in raw material prices, economic downturn, inappropriate addressing of customer grievances, and risk of natural or manmade disasters.

In order to mitigate these risks, the Company has adopted the implementation of the risk management policy focusing on the elements of risks which in the opinion of the Board may threaten the existence of the company. We through qualitative products, regular improvement in productivity, controls over overhead and Labour cost, internal audit of environmental safety and regulatory compliance, IATF 16949 certification, TPM certification, capturing customer complaints and response to them, have effective risk mitigating plans.

Further, pursuant to Regulation 21(5) of SEBI (Listing Obligation and Disclosure Requirements), Regulations, 2015, the Company has dissolved the Risk Management Committee, and the Risk Management System/policy of the Company is now to be looked after by the Audit Committee. The details of the same are mentioned in the **Annexure B** to this Board's Report.

Disclosure on Establishment of a Vigil Mechanism

Your Company is committed to highest standards of ethical, moral and legal business conduct. Accordingly, the Board of Directors has formulated a vigil mechanism through Whistle Blower Policy for directors and employees to deal with instances of unethical behaviour, actual or suspected, fraud or violation of Company's code of conduct or ethics policy and to report their genuine concerns or grievances to the Vigilance and Ethics Officer. Your Company hereby affirms that no Director/ Employee have been denied access to the

Chairman of the Audit Committee. The policy is available on the company's website www.shivamautotech.com.

Material Changes Affecting the Financial Position of the Company

There are no material changes and commitments affecting the financial position of the company which have occurred between the end of the financial year of the company to which the financial statements relate and on the date of this report.

Your Company was able to raise the short-term/long term funds needed for its working capital related requirements. To increase the liquidity in the system, the Company has availed Emergency Credit Line Guarantee Scheme issued by the National Credit Guarantee Trustee Company Limited ("NCGTCL"), a wholly owned Trustee Company of Government of India. The Company continues to focus on judicious management of its working capital.

Significant or Material Orders passed by the Regulators

No significant or material orders were passed by the Regulators or Courts or Tribunals which impact the going concern status and Company's operations in future.

Changes in the Nature of Business

There is no change in the nature of the business of the Company during the Financial Year 2020-21.

Annual Return

In terms of provisions of Section 92(3), 134(3)(a) of the Act read with Rule 12 of the Companies (Management and Administration) Rules, 2014, annual return of the Company for the Financial Year ended March 31, 2020 is available under the 'Investors' section of the Company's website www.shivamautotech.com.

Business Responsibility Report

SEBI (Listing Obligations and Disclosure Requirements) Regulations, 2015, as amended from time to time, mandates the top 1000 Listed Companies by market capitalisation to include Business Responsibility Report ("BR Report") in their Annual Report.

Your Company stands at no. 1168 based on market capitalisation as on March 31, 2021 issued by The National Stock Exchange of India Limited. Accordingly, a BR Report describing the initiatives taken by the Company from an environmental, social and governance perspective, does not forms part of this Report.

Particulars of Loan, Guarantees and Investments under Section 186 of the Companies Act, 2013

The Company has neither given any loans/guarantees / provided security nor have any investments been made by the Company under the provision of Section 186 of the Companies Act, 2013.

Particulars of Contracts or Arrangements with Related Parties

All contracts /arrangements/transactions entered by the Company during the financial year with the related parties were in the ordinary course of business and on arm's length basis and do not attract the provisions of Section 188 of the Companies Act, 2013. Hence, requirement of Form AOC-2 as required under Section 188(1) of the Act is not applicable to the Company.

All related party transactions are placed before the Audit Committee for its approval. During the year under review, the Audit Committee approved transactions through the omnibus mode in accordance with the provisions of the Act and SEBI Listing Regulations.

During the year under review, the Company had not entered into any contracts /arrangements/transactions with related parties which could be considered material in accordance with the policy of the Company on materiality of related party transactions. Suitable disclosure as required by the IND AS 24 has been made in the notes to the Financial Statements.

Conservation of Energy, Technology Absorption, Foreign Exchange Earnings and Outgo

The Company continues to use the latest technologies for improving the productivity and quality of its products and components. The details of Energy, Technology, Absorption, Foreign Exchange Earnings and Outgo are attached as **Annexure - C** to this Board's Report.

Statement in Respect of Adequacy of Internal Financial Control with Reference to the Financial Statements

The Company believes that Internal Control is one of the key pillars of governance, which provides freedom to the management within a framework of appropriate checks and balances. The Company has a robust internal control framework, which has been instituted considering the nature, size and risks in the business.

Your Company has adequate internal control for its business processes across departments to ensure efficient operations, compliance with internal policies, applicable laws and regulations. The internal controls are complemented, on an on-going basis, by an extensive program of internal audits being implemented throughout the year. The internal controls are designed to ensure that the financial and other records of the company are reliable for preparing financial statements and other data for maintaining the accountability of assets in conformity with established accounting principles and that the assets of the company are adequately safe-guarded against any significant misuse or loss.

The Company has robust ERP systems based on SAP platform. This ensures high degree of systems-based checks

and controls. The systems and processes are continuously improved by adopting best-in-class processes and automation and implementing the latest IT tools.

The Company also has an internal audit system which is conducted by an independent firm of Chartered Accountants. The same has also been verified by the statutory auditors who have reported that all the material internal financial controls exist during the financial year 2020-21. The internal audit plan is dynamic and aligned to the business objectives of the Company which is reviewed by the Audit Committee each quarter. Further, the Audit Committee monitors the adequacy and effectiveness of your Company's internal control framework.

Most importantly, the senior management sets the tone at the top of no tolerance to non-compliance and promotes a culture of continuous innovation and improvement.

IATF 16949/ISO 14001/ISO 45001 Accreditation

Your Company's manufacturing facilities are located at Binola, Haridwar, Kolar and Rohtak and we continue to maintain and uphold the prestigious IATF 16949:2016, ISO 14001:2015 and ISO 45001:2018 (Occupational Health & Safety Assessment Series) certifications from reputed leading Indian and International Certification Institutions. These certifications help in continuous improvements, besides emphasis being laid on prevention of defects, reduction of wastes, prevention of near misses and to ensure maximized customer delight.

Listing

Pursuant to Clause C(9)(d) of Schedule V of SEBI Listing Regulations, 2015, the shares of your Company are listed at The National Stock Exchange of India Limited and The BSE Limited, and pursuant to the SEBI Listing Regulations, the Annual Listing fees for the year 2021-22 have been paid to them well before the due date i.e. April 30, 2021. The Company has also paid the annual custodian fees for the year 2021-22 in respect of Shares held in dematerialized mode to National Securities Depository Limited (NSDL) & Central Depository Services Limited (CDSL).

The Company has complied with the requirements of Corporate Governance as stipulated under the SEBI Listing Regulations, as applicable.

Corporate Governance

Your Company is committed to follow the highest standards and principles of Corporate Governance with all integrity and fairness. The Company always places major thrust on managing its affairs with diligence, transparency, responsibility and accountability thereby upholding the important dictum that an organisation's corporate governance philosophy is directly linked to high performance. It has put in place an effective Corporate Governance system which ensures that provisions of the

Act and SEBI Listing Regulations are duly complied with, not only in form but also in substance.

A certificate from the Practising Company Secretary regarding the compliance of the conditions of Corporate Governance by the Company as stipulated under Chapter IV of SEBI Listing Regulations is also attached to this Report.

Separate detailed chapters on Corporate Governance, additional Shareholder information and Management Discussion and Analysis are attached herewith and form part of this Report. Declaration by CEO that the Board Members and Senior Management Personnel have complied with the Code of Conduct for the financial year 2020-21 is annexed with this report.

Disclosures for Maintenance of Cost Records

Your Company is not covered under subsection (1) of Section 148 of Companies Act, 2013 for maintenance of Cost records and accordingly such accounts and records are not required to be made and maintained.

Prevention of Sexual Harassment Cases

The Company has adopted a policy on prevention, prohibition and redressal of sexual harassment at workplace in line with the provisions of the Sexual Harassment of Women at Workplace (Prevention, Prohibition and Redressal) Act, 2013 (POSH Act) and the Rules thereunder. All women associates (permanent, temporary, contractual and trainees) as well as any women visiting the Company's office premises or women service providers are covered under this Policy.

The Company has constituted an "Internal Complaints Committee" under the POSH Act which is responsible for redressal of complaints related to sexual harassment. The Company aims at providing a workplace that enables employees to work without gender bias and sexual harassment.

The necessary disclosure in terms of requirements of SEBI Listing Regulations in this regard is given below:

- a) Number of complaints filed during the financial year – Nil
- b) Number of complaints disposed of during the financial year – N.A.
- c) Number of complaints pending as at the end of the financial year – N.A.

Various workshops and awareness Programmes w.r.t. prevention of sexual harassment has been carried out during the FY 2020-21

Directors' Responsibility Statement

Pursuant to the provisions of Section 134 (5) of the Companies Act, 2013, as amended, with respect to the

directors' responsibility statement, it is hereby confirmed:

- (i) That in preparation of annual accounts for the financial year ended March 31, 2021, the applicable accounting standards have been followed along with proper explanation relating to the material departures;
- (ii) That the directors of the company have selected such accounting policies and applied them consistently and made judgements and estimates that are reasonable and prudent, so as to give a true and fair view of the state of affairs of the Company as at March 31, 2021 and of the losses of the Company for the financial year ended March 31, 2021;
- (iii) That the directors' of the company have taken proper and sufficient care for the maintenance of adequate accounting records in accordance with the provisions of the Companies Act, 2013, for safeguarding the assets of the Company and for preventing and detecting fraud and other irregularities; and
- (iv) That the directors' of the company have prepared the annual accounts on a going concern basis.
- (v) That the directors, in the case of a listed company, had laid down internal financial controls to be followed by the company and that such internal financial controls are adequate and were operating effectively.
- (vi) That the directors had devised proper systems to ensure compliance with the provisions of all applicable laws and that such systems were adequate and operating effectively.

Managerial Remuneration

The details required pursuant to Rule 5(1) of the Companies (Appointment and Remuneration of Managerial Personnel), Rules, 2014 are provided in Corporate Governance Report attached as **Annexure – B** to this Board's Report.

Particulars of Employees

The information required under Section 197 of the Act read with Rule 5(2) of Companies (Appointment and Remuneration of Managerial Personnel) Rules, 2014, is attached as **Annexure - E** to this Board's Report.

Environment, Health & Safety

The Company is conscious of the importance of environmentally clean and safe operations. The Company's policy requires conduct of operations in such a manner so as to ensure safety of all concerned, compliances of environmental regulations and preservation of natural resources.

The Company has taken an initiative to preserve environment by indulging in paper recycling activity. The paper recycling pertains to the processes of reprocessing waste paper for reuse. Recycling paper preserves trees and forests. Every

ton of recycled paper saves about 17 trees. Recycled paper serves as an environmental friendly resource for paper manufacturers, saving costs and energy. **The Company has recycled approx. 4029 kgs of waste paper till March 31, 2021, contributing in saving 69 nos. of trees.**

The Company is committed to adhere to the highest standards of health and safety. It strives to provide its employees with a safe and healthy workplace. The Company continuous to focus on deploying behaviour based safety programmes and global safety standards across its locations. Its manufacturing units are certified with ISO-45001 (International Occupational health & safety management system and standards), abiding by the highest standards of safety.

The Company regularly conducts counselling and safety review meetings for the workers to appraise and educate them on the adoption of safety measures and avoidance of unsafe practices. Safe operating procedures, standards and systems have been laid down at all manufacturing locations. Prompt medical assistances are provided to its employees.

After Covid-19 was declared as a pandemic by WHO on March 11, 2020, the company suspended its operations considering the health and well-being of employees a priority. The key focus of the organisation was to engage, motivate and support employees and their families during the lockdown and to prepare them for the new normal.

After resuming operations, the Company consistently emphasised on maintaining a safe working environment. In the new normal, the following were actively implemented across operations:

- Mandatory face mask at workplace
- Virtual meetings
- Sanitization and temperature check at entry
- Disinfection of workstations
- Distanced workstations etc.

Vaccination- Since March 2020, life has been upended completely by the global pandemic. Employees have always been the Company's first priority and it is important to create a safe and secured ecosystem for them to thrive in. The Company conducted mass vaccination drives for employees as per GOI criteria by tie-up with vaccination centre in its plant.

Human Resource Development

The Company believes that people who feel truly associated with the organisation are the ones who perform to their peak capability. As a core part of our business strategy, it is committed to providing an environment where all of its employees feel enabled and have a sense of belonging. The

Company believes in greater diversity within the business will maximise collective capability, allowing leveraging the diversity of thought, and better reflecting and understanding the diverse customer base. This should, in turn, lead to better decision making and higher shareholder value.

The Company takes pride in the commitment, competence and dedication of its employees in all areas of the business. The Company has a structured induction process at all locations. Objective appraisal systems based on key result areas (KRAs) are in place for staff members.

Your Company treats its "human resources" as one of its most important assets. Your Company continuously invests in attraction, retention and development of talent on an ongoing basis. The Company's thrust is on the promotion of talent internally through job rotation and job enlargement. A significant effort has also been undertaken to develop leadership as well as technical/ functional capabilities in order to meet future talent requirement.

Board Diversity Policy

The Company recognizes and embraces the importance of a diverse board in its success. We believe that a truly diverse board will leverage differences in thought, perspective, knowledge, skill, regional and industry experience, cultural and geographical background, age, ethnicity, race and gender, which will help us, retain our competitive advantage. The Board has adopted the Board Diversity Policy which sets out the approach to diversity of the Board of Directors.

Proceeding Under Insolvency and Bankruptcy Code, 2016

The Company has not made any application or any proceeding pending under the Insolvency and Bankruptcy Code, 2016 (31 of 2016) ("IBC Code") during the year. Further, at the end of the year, Company does not have any proceedings related to IBC Code.

The details of difference between amount of the valuation done at the time of one-time settlement and the valuation done while taking loan from the banks or financial institutions along with the reasons thereof

During the year under review, the Company has not made one-time settlement therefore, the same is not applicable.

Policies

We seek to promote and follow the highest level of ethical standards in all our business transactions guided by our value system. The SEBI Listing Regulations mandated the formulation of certain policies for all listed companies. All our corporate governance policies are available on our website www.shivamautotech.com.

Following are the policies adopted by the company with their web links:

Policy	Web Link
Code of Conduct	http://www.shivamautotech.com/pdf/Code_of_Conduct_for_Board_Members_and_Senior_Mangement.pdf
Prohibition of Insider Trading	http://www.shivamautotech.com/Uploads/image/157imguf_ProhibitionofInsidertrading.pdf
Payment to Non- Executive Directors	http://www.shivamautotech.com/pdf/Payment_to_Non-Executive_Directors.pdf
Nomination and Remuneration Policy	http://www.shivamautotech.com/Uploads/image/163imguf_15.nrc.pdf
Board Diversity Policy	http://www.shivamautotech.com/pdf/Board_Diversity_Policy.pdf
Records and Archives Policy	http://www.shivamautotech.com/pdf/records_and_archives_policy.pdf
Related Party Transaction Policy	http://www.shivamautotech.com/Uploads/image/161imguf_6.rpt.pdf
Anti-Harassment Policy	http://www.shivamautotech.com/pdf/policy_on_prevention_of_sexual_harassment.pdf
Risk Management Policy	http://www.shivamautotech.com/pdf/Risk_Management_Policy.pdf
Whistle Blower Policy	http://www.shivamautotech.com/pdf/WhistleBlowerPolicy.pdf
Familiarization Policy	http://www.shivamautotech.com/pdf/Familiarization_Programme_for_Independent_Director.pdf
Policy on Determination and Disclosure of Materiality of Events	http://www.shivamautotech.com/pdf/n1_Policy_on_Determination_and_Disclosure_of_Materiality_of_Events.pdf

Secretarial Standards

During the year under review, your Company had complied with all the applicable Secretarial Standards issued by the Institute of Company Secretaries of India.

Acknowledgments

Your Company's organisational culture upholds professionalism, integrity and continuous improvement across all functions as well as efficient utilisation of the Company's resources for sustainable and profitable growth.

The Directors express their appreciation for the sincere co-operation and assistance of Central and State Government Authorities, Bankers, Customers, Suppliers and Business Associates. Your Directors also wish to place on record their deep sense of appreciation for the committed services by your Company's employees. Your Directors acknowledge with gratitude the encouragement and support extended by our valued shareholders.

The Board would like to reiterate its commitment to continue to build the organization into a truly world-class enterprise in all aspects.

Place: Gurugram
Date: August 13, 2021

For and on behalf of the Board
Sd/-
Neeraj Munjal
Managing Director
DIN: 00037792

For and on behalf of the Board
Sd/-
Charu Munjal
Whole Time Director
DIN:03094545

ANNEXURE 'A' TO BOARD'S REPORT

MANAGEMENT DISCUSSION & ANALYSIS REPORT

It was a year of COVID-19 as it subsumed everything in its wake! FY 2019-20 was a witness of the start of the COVID-19 pandemic. However, FY 2020-21 was simply about the COVID-19 pandemic and its impact on individuals, communities, companies and nations.

Industry Structure and developments

The year under review had two distinct themes, the first half of the year saw the impact of COVID-19 induced lockdowns wiping out majority of the first quarter of the fiscal and the second half of the year showed a remarkable recovery in automobile production, leading to growth in sales.

Further, the automobile sector was already facing challenges pre-COVID times due to transition of automobile norms from BS IV to BS VI effective from April 01, 2020. Thus the industry was already witnessing a slowdown as the growth rate fell to 5.2% in FY 2018-19. It reported further negative growth with a fall of 14.2% in FY 2019-20 owing to overall economic slowdown, lack of government stimulus, liquidity crisis and poor consumer sentiments in face of the pandemic. The auto industry experienced a considerably poor Q1, FY 2020-21, but found the tide turning with steady increase in demand during the remaining quarters.

India faced an uncertain FY 2020-21. The fiscal year began with a lockdown leading to multiple socio-economic challenges, such as mass exodus of the migrant labour population, subdued demand as consumers became cautious, job losses and reduced salary. The Indian economy contracted about 24% in Q1, FY 2020-21, with most businesses recording a washout quarter. As the lockdown gradually eased, with aggressive government policies to spur the economy, industries saw some demand returning. However, consumer sentiment remained weak, resulting in low offtake.

Imports share a significant part of our key inputs. This pandemic has led to disruption in supply chain management that may impact business goals of the Company. We have been engaged in exploring alternative vendors for key inputs and also focusing on exploring new opportunities in sales.

As per the data from **India's National Statistical Office**, the country's GDP contracted by 7.3% for FY 2020-21 as compared to the growth rate of 4.2% in the previous fiscal.

The prospects of a global economic revival still remain uncertain due to the emergence of new virus strains in different parts of the world. However, the vaccination drive along with government support remains the key to navigate through these trying times. As the research fraternity came together to develop the coronavirus vaccine in record time, it offered a clear peek into the strength and agility of humankind in a manner never witnessed before. Going ahead, rapid vaccination remains the key to control the pandemic and bounce the economy back to pre-Covid growth levels, and upwards.

As per **International Monetary Fund ("IMF")** projections in March 2021, Indian economic growth is estimated at 12.5% in FY 2021-22 and 6.9% in FY 2022-23.

The demand for Passenger Vehicles has grown in FY 2020-21 on the back of some pent-up demand but more importantly a structural shift in personal mobility preference arising out of an urge to break free in the aftermath of the restrictions in travelling during the COVID-19 pandemic situation as well as resurgence in the rural markets. Passenger car sales are dominated by small and mid-sized cars. With the shutdown of all non-essential services accompanied by liquidity and cash crunch, the demand for Commercial Vehicles was severely impacted in the first half of FY 2020-21.

While there are short term challenges on account of COVID-19 pandemic, Commercial Vehicle industry is likely to rebound and show recovery after witnessing two consecutive years of double digit de-growth. Demand for Commercial Vehicles, particularly Medium and Heavy Commercial Vehicles, is likely to also benefit from various government initiatives to help revive the economy.

According to the **Society of Indian Automobile Manufacturers ("SIAM")**, the industry saw a huge decline of 79% in Q1 numbers. As the lockdown gradually lifted, demand made a comeback to the market even as the production for Q2 continued to be negative with a de-growth of 7%. Q3 marked the beginning of the recovery phase, which can be largely attributed to the pent-up demand, positive agricultural economics and a moderate shift from public to private transport. During this quarter, Passenger Vehicle (PV) and Two- Wheeler (2W) segments gained momentum while Commercial Vehicle (CV) and Three Wheeler (3W) segments were in the negative zone.

SIAM data showing Automobile Domestic Sales Trends for 2019-20 and for 2020-21 as mentioned below would corroborate the above narrative in general.

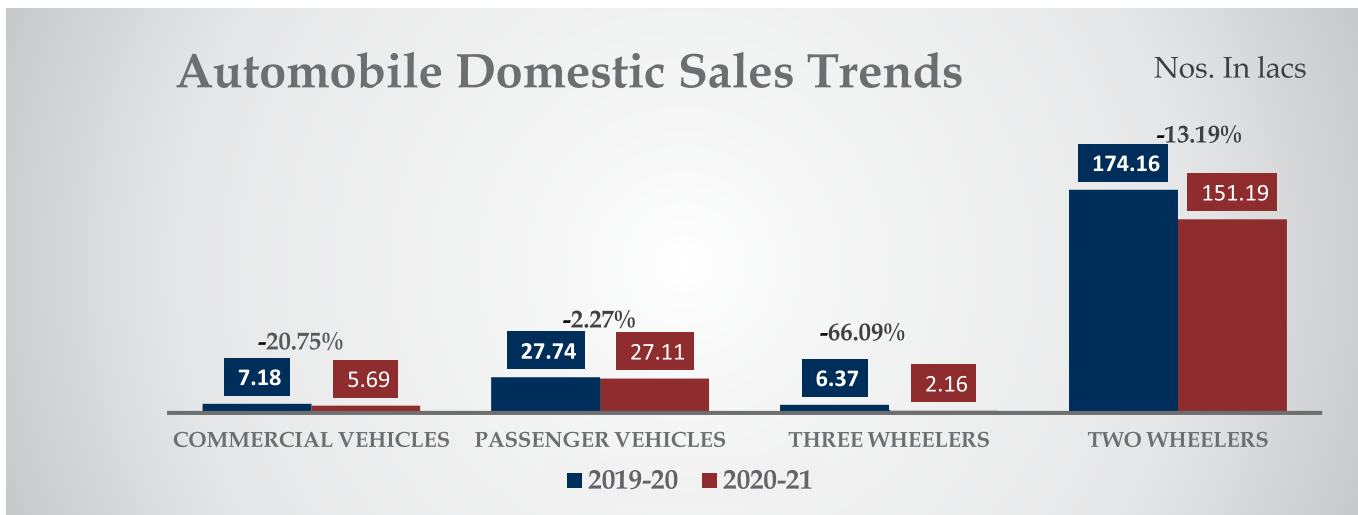

Government Initiatives

The automobile industry is supported by various factors such as availability of skilled labour at low cost, robust R&D centres, and low cost steel production. The industry also provides great opportunities for investment and direct and indirect employment to skilled and unskilled labour. The Indian auto industry is expected to record strong growth in FY 2021-22, post recovering from effects of COVID-19 pandemic. India is expected to be the world's third-largest automotive market in terms of volume by 2026.

Government has come out with Automotive Mission Plan (AMP) 2016-26 which will help the automotive industry to grow and will benefit Indian economy in the following ways: -

- Contribution of auto industry in the country's GDP will rise to over 12 per cent.
- Around 65 million incremental number of direct and indirect jobs will be created.
- End of life Policy will be implemented for old vehicles.

The Government of India has introduced vehicle scrappage policy. In scrappage policy, recycled material will be useful for the automobile industry as it will reduce cost of manufacturing cars, buses, and trucks, increasing India's competitiveness in international markets. An incentive-based mechanism could make the scheme lucrative and encourage people to scrap their old vehicles and replace them with new ones. This scrappage policy will result in boosting demand for the automotive sector. The Indian automotive industry has welcomed this new proposal.

Notable initiatives such as special package under 'Atmanirbhar Bharat'; liquidity support for banks and

financial institutions; liberalization of Foreign Direct Investment (FDI) norms; creation of National Infrastructure Pipeline (NIP); Production-Linked Incentive (PLI) scheme to boost domestic manufacturing – are all expected to reinvigorate the economy. Supported by strong fiscal and quasi-fiscal measures along with mass vaccination drives, India's growth is likely to rebound to 12.5% in FY 2021-22 and 6.9% in FY 2022-23. With this, India will leave China behind and become the fastest growing economy in the world. However, the second wave of coronavirus infections, trajectory of vaccination drive and its impact on contact intensive sectors may pose challenges for the economy. (Source: IMF World Economic Outlook, April 2021)

In March 2021, the government announced to offer fresh incentives to companies making electric vehicles (EVs) as part of a broad auto sector scheme. The scheme is expected to attract US\$ 14 billion of investment in the next five years.

Further, this period requires coordinated efforts, not only within the medical fraternity, but also between various governments, between the government and the industry, within industries, between citizens and the government, between strategy and execution. These are times when real life heroes rise to the occasion and we begin to appreciate the small wonders of life that we had taken for granted. The world will undoubtedly recover faster with collaboration, which is the mantra of the times. The pandemic, in a way, is also uniting the world.

The easing of policies and the gradually improving business confidence in response to government reforms, particularly for small and medium enterprises (SMEs) and micro, small and medium-sized enterprises (MSMEs), which now have greater access to finance, are likely to enhance growth.

Market Size

The industry can be broadly classified into organised and unorganised sectors. The organised sector caters to original equipment manufacturers (OEMs) and consist of high-value precision instruments while the unorganised sector comprises low-valued products and caters mostly to the aftermarket category.

Automobile component industry's revenue stood at US\$ 49.3 billion in FY20, up from US\$ 39.05 billion in FY16. Export of auto components grew at a CAGR of 7.6% to reach Rs. 102,623 crore (US\$ 14.5 billion) during the same time. As per Automobile Component Manufacturers Association (ACMA), automobile components export from India is expected to reach US\$ 80 billion by 2026. The Indian auto components industry is expected to reach US\$ 200 billion in revenue by 2026.

The Indian automotive industry is the pillar of the manufacturing sector and provides employment to a large pool of people. Being the fourth largest automotive market globally, the sector plays a vital role in India's aspiration to become a USD 5 Trillion economy. Increasing urbanization, large working-age population, rising incomes and strong impetus on infrastructure and construction sectors have been driving the industry's growth over the years.

India is the second-most populous country in the world and has a sizeable chunk of middle and low income population. The penetration of two-wheelers in India remains low at ~110 per 1000 people vs. an average of ~240 in Southeast Asian countries, hence the untapped potential in the country is huge. Commuting continues to be a challenge due to congestion in urban areas and the need to travel long distances in rural areas for day-to-day activities. Two-wheelers, ranging from motorcycles and scooters to mopeds, have emerged as dependable mobility solutions that make commuting faster and easier.

The global two-wheelers market has witnessed significant volatility in recent years, in terms of changes in safety norms, advance payment of insurance, emission norms etc., Each of these can be considered phenomenal changes, introduced may be once in a decade. In spite of these, owing to strong underlying drivers, demand stayed resilient and is expected to revive significantly over the next five years.

The motorcycles and scooters industry experienced a short-term dip in demand with the onset of Covid-19, resulting in a decline in manufacturing and sales. As a result, global motorcycle sales in 2020 dropped 14% in comparison to the previous year to reach 56.5 million units.

Post the pandemic, two new trends have emerged in the industry. First, the demand for personal mobility has increased, offering a level playing field to two-wheelers. Second, pent up demand for two-wheelers increased sales,

mostly because two-wheelers are also income enablers for a large section of the population. As a result, in the second half of 2020, the global motorcycle market witnessed visible growth in many countries.

Segment wise Domestic Sales

According to SIAM data, the industry produced a total 22,652,108 vehicles including Passenger Vehicles, Commercial Vehicles, Three Wheelers, Two Wheelers and Quadricycles in April-March 2021 as against 26,353,293 in April-March 2020, registering a de-growth of (-) 14.04 percent over the same period last year.

The sale of Passenger Vehicles declined by (-) 2.24 percent in April-March 2021 over the same period last year. Within the Passenger Vehicles, the sales of Passenger Cars and Vans declined by (-) 9.06, percent and (-) 17.62 percent respectively while sales of Utility Vehicles increased by 12.13 percent in April-March 2021 over the same period last year.

The overall Commercial Vehicles segment registered a de-growth of (-) 20.77 percent in April- March 2021 as compared to the same period last year. Within the Commercial Vehicles, Medium & Heavy Commercial Vehicles (M&HCVs) and Light Commercial Vehicles (LCVs) declined by (-) 28.40 percent and (-) 17.30 percent respectively in April-March 2021 over the same period last year.

Sale of Three Wheelers declined by (-) 66.06 percent in April-March 2021 over the same period last year. Within the Three Wheelers, Passenger Carrier and Goods Carrier declined by (-).74.49 percent and (-) 26.38 percent respectively in April-March 2021 over April-March 2020.

Two Wheelers sales registered a de-growth of (-) 13.19 percent in April-March 2021 over April-March 2020. Within the Two Wheelers segment, Scooters, Motorcycles and Mopeds declined by (-) 19.51 percent, (-) 10.65 percent and (-) 3.07 percent respectively in April-March 2021 over April-March 2020.

Exports

In April-March 2021, overall automobile exports declined by (-)13.05 percent. Passenger Vehicles, Commercial Vehicles, Three Wheelers and Two Wheelers exports also declined by (-) 38.92 percent, (-) 16.64 percent, (-) 21.67 percent, and (-) 6.87 percent respectively.

Opportunities & Threats

We have laid out our new vision —to be the future of mobility. This entails exploring emerging opportunities in the mobility space while continuing to excel in the core mobility segments the Company operates in. Our continued focus on corporate governance and on enhancing the efficiency curve with the use of talent, teamwork and technology will enable us to lead the way for the industry.

Comprehensive efforts were demonstrated across the Company to optimise capacities, investments, and obsolescence across the value chain.

OPPORTUNITIES

- India is emerging as **global hub** for auto component sourcing.
- In September 2015, **Automotive Mission Plan 2016-26** was unveiled which targets a fourfold growth for the sector.
- **E-mobility** – Emerging preferences towards battery driven vehicles provide new opportunities for growth. The Company's ongoing projects on development of braking system and transmission system for electric vehicles, position it to capitalise on new market opportunities in this segment.
- **100 per cent FDI** allowed under automatic route for auto component sector.
- Government announces an incentive-based **vehicle scrappage policy** for removal of the old and polluting vehicles, bringing down vehicular air pollutants, improving road and vehicular safety. It will also help achieve better fuel efficiency, formalize the informal vehicle scrapping policy and boost the availability of low cost raw material for the automotive, steel and electronics industry.
- **Personal mobility** – Post Covid-19, demand for personal mobility has increased significantly, providing opportunities for growth across geographies.

THREATS

- Vehicle Electrification development needs call for systems integration of heat management, energy management, acoustics, software integration; predictive analysis; attribute engineering, vehicle package design, optimised electrical distribution, durable electronics, verification and validation and it seems this transition is not in harmony with the future goals of the industry. Usually, an internal combustion engine (ICE) of most of the cars works on more than 2,000 moving parts, but the engine of an electric vehicle doesn't require more than 20 similar parts/components.
- Increase in raw material cost can impact the profitability of the Company.
- The economic downturn or slowdown in the Company's key markets can result in decreased volumes and impact capacity utilisation.

No doubt, an environment of fear is eclipsing the industry. But it is equally true that the industry is all set to become

the third-largest in the world by 2025, and globalization is considered auspicious rather than a menace.

Road Ahead

The rapidly globalising world is opening newer opportunities for the transportation industry, especially while it makes a shift towards electric, electronic and hybrid cars, which are deemed more efficient, safe, and reliable mode of transportation. Over the next decade, this will lead to newer verticals and opportunities for auto-component manufacturers, who would need to adapt change via systematic R&D.

Safety first

Our commitment to Environment, Health and Safety (EHS) is integral to our operations. We are focused on creating a safe and enabling working environment at all our manufacturing plants.

Our main focus during this pandemic year was to ensure the safety and well-being of everyone in the ecosystem. As things stand today, we continue to keep health and safety as our top priority. We have always been people centric and know that our people are our family. We are also of the firm belief that our relationships are the key to our success.

BSVI transition – Challenges and solutions

Vertical ramp up and ramp down between BS-IV and BS-VI was crucial considering the numbers to be managed across the entire plant setup. However, considering that the manufacturing set-ups are developed as part of a long-term strategy, the challenge could be addressed with well thought comprehensive planning and cohesive team work. We are now geared up to ramp up production rapidly.

Product Wise Performance

All products of the Company come under single primary business segment. Therefore, requirement for analysing segment wise or product wise performance does not arise.

Outlook

According to the International Monetary Fund (IMF), global prospects remain highly uncertain. The outlook depends not only on the outcome of the battle between the virus and vaccines—it also hinges on how effectively economic policies are deployed to limit lasting damage from this unprecedented crisis. India is the only country expected to register a double-digit growth this fiscal. However, the rapid spread of the second wave of COVID-19 might temper this outlook.

COVID-19 has grave consequences for the automobile industry and all related sectors. In its outlook in April 2021, SIAM estimates Passenger Vehicle (PV) sales to grow

between 3-5% and Commercial Vehicle (CV) at 10-12%. The Two-Wheeler (2W) segment is expected to grow between 5-7% and the Three-Wheeler (3W) segment is pegged to grow between 7-9%. With the imposition of lockdowns across the country, the outlook might be subject to change.

However, the automobile industry is supported by various factors such as availability of skilled labour at low cost, robust R&D centres, and low cost steel production. The Indian government has implemented a slew of reforms, including labour reforms, corporate tax cuts, and various other schemes that will aid economic recovery in the coming fiscal. Along with this, normal monsoons, rural spending and rapid vaccination will remain key factors for ushering an economic rebound.

The two-wheelers remain the most cost-effective and fastest mode of last mile connectivity, and is an income enabler for many. A preference for personal mobility induced by the pandemic could aid near-term two-wheelers demand, which has been impacted by repeated waves of Covid-19. However, a quick recovery in industrial production, rise in exports and increased consumer spending will provide a shot in the arm for the economy to clock double digit growth in the near to medium term.

Growth in e-commerce and emergence of unicorns from the Indian ecosystem will play a critical role in driving digitisation in the economy. The increasing acceptance of food delivery, grocery, retail, pharmacy and transportation will usher sustained growth in the long-term for automobile industry. These enterprises not only bring comfort and convenience to the doorstep of the end-user, but also provide employment opportunities to many.

Risk and Concerns from the point of view of the organisation

The Company has in place a robust risk management framework that identifies and evaluates business risks and opportunities. The Company recognises that these risks need to be handled effectively and mitigated to protect the interest of the shareholders and stakeholders, achieve business objectives and create sustainable value and growth. The Company's risk management processes focus on ensuring that these risks are identified promptly and a mitigation action plan is implemented and monitored periodically to ensure that the risks are being addressed accordingly.

Internal Control System and its Adequacy

Your Company has exhaustive internal control systems that are aligned to its business requirements. The Company regularly monitors the risks and has in place focused risk mitigation strategies. Internal and external audit teams continuously monitor the adequacy and effectiveness of the internal control environment across the Company and the status of compliance with operating systems, internal policies and regulatory requirements.

The Internal Auditor reports directly to the Board through Audit Committee. The Internal Auditor has been assigned with the tasks for setting up of Inventory norms, Inventory optimization, scrap reconciliation, common spare management, BOM correction and verification. The Internal Auditor presents to the Audit Committee, the detailed analysis of the tasks assigned to them in every meeting of the Committee. The Audit Committee meets periodically to review the adequacy and efficacy of the internal control systems.

Discussion on Financial Performance with respect to Operational Performance

The Company's Board of Directors is responsible for the matters stated in Section 134(5) of the Companies Act, 2013 ("the Act") with respect to the preparation of these Ind AS financial statements that give a true and fair view of the financial position, financial performance including other comprehensive income, cash flows and changes in equity of the Company in accordance with the Indian Accounting Standards (Ind AS) prescribed under Section 133 of the Act read with the Companies (Indian Accounting Standards) Rules, 2015, as amended, and other accounting principles generally accepted in India. The financials have been prepared considering the above requirements of applicable laws.

During the year under review, revenue from operations was Rs.48,741.15 lacs as compared to Rs.58,783.25 lacs in 2019-20, registering a decrease of 17.08%.

Despite the challenges posed by the pandemic, the Company adapted to the changing business needs. The state of preparedness and quick countermeasures taken by the Company had started to show improvements, **before interest, depreciation and taxes, the Company has achieved operational profit of Rs. 8,103.24 Lacs increased by 53.96% in year 2020-21 over Rs. 5,263.27 Lacs in 2019-20.**

Key Financial Ratios

In accordance with the SEBI (Listing Obligations and Disclosure Requirements) Regulations, 2015 the Company is required to give details of significant changes (i.e. change of 25% or more as compared to the immediately previous financial year) in key financial ratios.

S. No.	Ratio	FY 2020-21	FY 2019-20	% Change
(i)	Debtor Turnover Ratio	52.76	41.27	27.85
(ii)	Inventory Turnover Ratio	65.38	52.66	24.15
(iii)	Interest Coverage Ratio	1.43	0.99	43.74
(iv)	Current Ratio	0.69	0.54	27.78
(v)	Debt to Equity Ratio	4.25	3.18	33.65
(vi)	Operating Profit Margin (%)	16.51	8.94	84.68
(vii)	Net Profit Margin (%)	-5.03	-9.23	45.50
(viii)	Return on Net Worth*(%)	-19.93	-27.48	27.47

*Return on Net Worth is computed as Net Profit by Average Net Worth. Decline in Return on Net Worth is primarily due to decline in Net Profit.

Human Resources & Industrial Relations

Human Resources continued to play a pivotal role in managing, guiding and motivating the Company's workforce. Your company has skilled and unskilled workforce to give a competitive edge in an ever-changing industry landscape. With well-developed, well-founded strategies and establish policies, standards and systems, such as recruitment, on-boarding, training, performance management, mediation, legal compliance, and compensation administration, your company keeps a focus on its Human Resource and continues to invest in a wide variety of HR activities for its sustainable growth and social objectives.

Cautionary Statement

Certain Statements in the Management Discussion and Analysis describing the company's objectives, projections, estimates and expectations or predictions may be 'forward looking statements' within the meaning of applicable laws and regulations. It cannot be guaranteed that these assumptions and expectations are accurate or will be realized. Actual results could differ materially from those expressed or implied. Important factors that could make a difference to the Company's operations include economic conditions affecting demand / supply and price conditions in the domestic and overseas markets in which the Company operates, changes in the Government regulations, tax laws and other statutes and incidental factors.

ANNEXURE 'B' TO BOARD'S REPORT

REPORT ON CORPORATE GOVERNANCE

Pursuant to Regulation 34 read with Schedule V to the Securities and Exchange Board of India (Listing Obligations and Disclosure Requirements) Regulations, 2015 (hereinafter referred to as "Listing Regulations"), a report on Corporate Governance is given below:

This Report, therefore, states compliance as per requirements of the Companies Act, 2013 and Listing Regulations, as applicable to the Company. As have been seen, the Company's corporate governance practices and disclosures have gone well beyond complying with the statutory and regulatory requirements as stipulated in the applicable laws, including Listing Regulations.

1. COMPANY'S PHILOSOPHY ON CODE OF CORPORATE GOVERNANCE

Corporate governance at Shivam Autotech Limited ("Company") is strongly founded on its core guiding values viz. passion, integrity, respect, courage and responsibility in all its actions, operations and engagement with the stakeholders and society at large. The Company believes that good corporate governance emerges from the application of the best and sound management practices and compliance with the laws coupled with adherence to the highest standards of transparency and business ethics.

Simultaneously, in keeping with the best practices, your Company seeks to execute the practices of corporate governance by maintaining strong business fundamentals and by delivering high performance through relentless focus on the Transparency, Accountability, Professionalism, Trusteeship, working towards sustainable development-environmental and social & Continuous focus on training and development of employees and workers.

Achieving milestones is important for us, but achieving them the right and ethical way is all the more important and essential. Corporate Governance brings direction and control to the affairs of the Company in a fashion that ensures optimum return for stakeholders. Corporate governance is the broad framework which defines the way the Company functions and interacts with its environment. Moreover, the Company in its journey towards sustainability is integrating sustainability practices in its corporate governance system which goes beyond compliance. The Company is guided by a key set of values for all its internal and external interactions.

The Company also believes that corporate governance has a role to ensure that the Directors of the Company are subject to their duties, obligations, accountability and responsibilities, to act in the best interest of the Company and to remain accountable to the shareholders and other beneficiaries for their corporate actions. The Company also believes that an active, well informed and independent Board is necessary to ensure the highest standard of corporate governance. The Board is responsible for and committed to the sound principles of corporate governance in the Company.

Thus, overall corporate governance norms have been institutionalised as an enabling and facilitating business process at the Board, Management and at all operational levels. The Company has complied with the requirements of Corporate Governance as stipulated under the Listing Regulations, as applicable, the details of which are as under:

2. BOARD OF DIRECTORS

The Board of Directors, being at the core of its Corporate Governance practice, plays the most pivotal role in overseeing how the management serves and protects the long term interests of all our stakeholders. The Board is entrusted with an ultimate responsibility of management, directions and performance of the Company. The Board exercises its duties with due care, skill and diligence. It sets strategic goals and seeks accountability for their fulfilment. It also directs and exercises appropriate control to ensure that the Company is managed in a manner that fulfils stakeholder's aspirations and societal expectations.

As its primary role is fiduciary in nature, the Board provides leadership, strategic guidance, objective and independent view to the Company's management while discharging its fiduciary responsibilities, thereby ensuring that the management adheres to high standards of ethics, transparency and disclosure.

2.1 Composition of the Board

The Board consists of an optimal combination of Executive Directors and Independent Directors, representing a judicious mix of professionalism, knowledge and experience. The Directors bring in expertise in the fields of strategy, management, human resource development, Industrial, Managerial, Technical, legal, Financial and Banking background among others. The Company is managed by the Board of Directors in co-ordination with senior management team. The composition and strength of the Board is periodically reviewed to ensure that it remains aligned with statutory as well as business requirements.

The Listing Regulations mandate that for a Company with a non-executive Chairman, at least one – third (i.e. 33%) of the Board should be Independent Directors. As on March 31, 2021, our Board comprised of 6 (Six) directors with a Non-Executive and Independent Chairman, a Managing Director, one Whole-time Director (Woman Director), one Non-Executive and Non-Independent Director and three Independent Directors (including Chairman & one Woman Director). Independent Directors constitute 50% of the Board's strength – more than the requirements of the Companies Act, 2013 and the Listing Regulations.

Mr. Neeraj Munjal, Managing Director belongs to the promoter family. Dayanand Munjal Investments Private Limited is holding Company under promoter category and owns 74.80% equity in the Company. Mrs. Charu Munjal is Whole Time Director of the Company designated as "Executive Director". Mr. Neeraj Munjal, Managing Director and Mrs. Charu Munjal, Whole Time Director being spouse are related to each other. Apart from these, the Board constitutes of Independent Directors namely Mr. Bhagwan Dass Narang, Ms. Jyothi Prasad[^] & Mr. Sunil Chinubhai Vakil^{^^} and Non-Executive and Non-Independent Director namely Dr. Anil Kumar Gupta. These directors bring to the Board wide range of experience & skills.

Mr. Sunil Kant Munjal (DIN: 00003902), Chairman & Independent Director has resigned from the directorship with effect from September 24, 2020 in order to meet additional commitments at the personal level. The Board placed on record its appreciation for his invaluable contribution, guidance & support during his tenure with the company. Pursuant to Clause (7B) of Para A of Part A of Schedule III of SEBI (Listing Obligations and Disclosure Requirements) Obligations, 2015, there were no other material reasons other than those provided.

[^]Ms. Jyothi Prasad has been appointed as a Non-Executive Independent Director of the Company w.e.f. November 13, 2019, and her appointment as a Non-Executive Independent Director is approved by the shareholders at the 15th Annual General Meeting held on September 30, 2020.

^{^^}Mr. Sunil Chinubhai Vakil has been appointed as a Non-Executive Independent Director of the Company w.e.f. December 21, 2020, subject to the approval of shareholders at the ensuing Annual General Meeting.

2.2 Board / Committee Meetings

The Board meets at regular intervals to discuss and decide on business strategies/policies and review the financial performance of the Company. The Board Meetings are pre-scheduled and a tentative annual calendar of the Board Meeting is circulated to the Directors well in advance to facilitate them to plan their schedules accordingly. In case of business exigencies, the Board's approval is taken through circular resolutions. The circular resolutions are noted at the subsequent Board Meeting.

Board Meetings and Attendance of each Director at the Board Meetings and the last Annual General Meeting

During the Financial Year 2020-21, 8 (Eight) meetings of the Board of Directors of the Company were held on June 10, 2020, July 28, 2020, August 31, 2020, September 25, 2020, November 09, 2020, December 03, 2020, December 21, 2020 and February 12, 2021. The intervening gap between the meetings was within the period prescribed under the Companies Act, 2013 read with MCA General Circular No. 11/2020 dated March 24, 2020 and Listing Regulations read with SEBI Circular SEBI/HO/CFD/CMD1/CIR/P/2020/3 dated March 19, 2020 & SEBI/HO/CFD/CMD1/CIR/P/2020/110 dated June 26, 2020 and the Secretarial Standards issued by the Institute of Company Secretaries of India.

The details of attendance of Directors in the Board meetings are as under:

Name of Directors	No. of Board Meetings held	No. of Board Meetings attended	Attendance at last AGM
Mr. Bhagwan Dass Narang ¹	8	8	Yes
Mr. Neeraj Munjal	8	8	Yes
Mrs. Charu Munjal	8	7	Yes
Mr. Sunil Kant Munjal ²	3	3	Not Applicable
Dr. Anil Kumar Gupta	8	8	Yes
Ms. Jyothi Prasad	8	8	Yes
Mr. Sunil Chinubhai Vakil ³	1	1	Not Applicable

The information as required under Schedule II of the Listing Regulations is made available to the Board of Directors. Board members are given agenda papers along with necessary documents and information in advance of each meeting of the Board. Adequate information is circulated as part of the Board papers and is also made available at the Board Meeting to enable the Board to take informed decisions.

2.3 Independent Directors

During the year, a separate meeting of the Independent Directors was held on February 12, 2021. All the Independent Directors were present at the Meeting and reviewed among other matters,

- the performance of non-independent Directors and the Board as a whole;
- the performance of the Chairperson of the Company after considering the views of Executive and Non-Executive Directors;
- assessed the quality, quantity and timeliness of flow of information between the Company Management and the Board that is necessary for the Board to effectively and reasonably perform their duties.
- competition strategy, leadership, strengths and weaknesses, governance, compliance, human resource matters etc.

All the Independent Directors have given their view on the above-mentioned points to the Company in their performance evaluation report.

Independent Directors confirmation by the Board

All Independent Directors have given declarations that they meet the criteria of independence as laid down under Section 149(6) of the Companies Act, 2013 and Regulation 16(1) (b) of the Listing Regulations.

In the opinion of the Board, the Independent Directors, fulfil the conditions of independence specified in Section 149(6) of the Companies Act, 2013 and Regulation 16(1) (b) of the Listing Regulations.

Independent Director Databank Registration

Pursuant to a notification dated October 22, 2019 issued by the Ministry of Corporate Affairs, all directors have completed the registration with the Independent Directors' Databank. Requisite disclosures have been received from the Directors in this regard.

Number of Independent Directorships

Pursuant to Regulation 17A of the Listing Regulations, Independent Directors of the Company do not serve as Independent Director in more than seven listed companies. Further, the Managing Director and Whole time Director of the Company does not serve as an Independent Director in any listed entity.

¹ Appointed as the Chairman of the Company w.e.f. November 09, 2020

² Resigned as Independent Director w.e.f. September 24, 2020

³ Appointed as an Additional (Non-Executive Independent) Director w.e.f. December 21, 2020

2.4 Number of other Board of Directors' Committees in which the Director is a Member or Chairperson

In accordance with Regulation 17A of the Listing Regulations, none of the Directors hold directorship in more than 7 listed companies with effect from April 1, 2020. Further, in accordance with Regulation 26 of the Listing Regulations, none of them hold memberships of more than 10 Committees of the Board nor any Director is a Chairperson of more than 5 Committees of the Board (viz. Audit Committee and Stakeholders' Relationship Committee) in Public Limited Companies whether listed or not, excluding private limited companies, foreign companies and companies under Section 8 of the Companies Act 2013.

Every director has informed the listed entity about their Directorships, committee positions he or she occupies in other listed entities and changes in their positions as and when they took place. Relevant details of the Board of Directors as on March 31, 2021 are given below:

Name	Category	No. of Directorships in listed entities including this listed entity	No. of Committee Memberships in Audit/ Stakeholder Committee including this listed entity	No. of post of Chairperson in Audit/ Stakeholder Committee held in listed entity including this listed entity
Mr. Bhagwan Dass Narang <i>Chairman</i> ⁴	Independent Director	2	5	2
Mr. Neeraj Munjal <i>Managing Director</i>	Executive Director	1	1	0
Mrs. Charu Munjal <i>Executive Director</i>	Executive Director	2	0	0
Dr. Anil Kumar Gupta	Non-Executive Director	2	2	0
Ms. Jyothi Prasad	Independent Director	2	5	3
Mr. Sunil Chinubhai Vakil ⁵	Independent Director	1	2	1

None of the Independent Directors holds any shares (as own or on behalf of other person on beneficial basis) in the Company as on March 31, 2021.

Notes:

1. Private Limited Companies, Foreign Companies and Companies under Section 8 of the Companies Act, 2013 are excluded for the above purposes.
2. Only Audit committee and Stakeholders' Relationship committee are considered for the purpose of committee positions in accordance with Regulation 26 of Listing Regulations.
3. Mr. Neeraj Munjal and Mrs. Charu Munjal, being spouses are related to each other. None of other directors are related inter-se.

Name of equity listed entities where directors of the Company held directorships as on March 31, 2021

Name of Director	Name of Listed entities	Category
Mr. Bhagwan Dass Narang	a) Shivam Autotech Limited	Chairman, Non – Executive and Independent Director
	b) Dish TV India Limited	Non – Executive and Independent Director
Mr. Neeraj Munjal	a) Shivam Autotech Limited	Managing Director
Mrs. Charu Munjal	a) Shivam Autotech Limited	Whole-Time Director
	b) Munjal Showa Limited	Non – Executive and Non – Independent Director
Dr. Anil Kumar Gupta	a) Shivam Autotech Limited	Non – Executive and Non – Independent Director
	b) Akar Auto Industries Limited	Non – Executive and Independent Director
Ms. Jyothi Prasad	a) ShivamAutotech Limited	Non – Executive and Independent Director
	b) Granules India Limited	Non – Executive and Independent Director
Mr. Sunil Chinubhai Vakil ⁶	a) Shivam Autotech Limited	Non – Executive and Independent Director

⁴ Appointed as the Chairman of the Company w.e.f. November 09, 2020

⁵ Appointed as an Additional (Non-Executive Independent) Director w.e.f. December 21, 2020

⁶ Appointed as an Additional (Non-Executive Independent) Director w.e.f. December 21, 2020

2.5 Re - Appointment of Directors

In accordance with the Companies Act, 2013 and the Articles of Association of the Company, Dr. Anil Kumar Gupta, Non-Executive Director of the Company, retire by rotation at the ensuing Annual General Meeting and being eligible, offer himself for re-appointment.

Relevant Information of Directors proposed to be appointed/re-appointed at the Annual General Meeting is given in the Notice of the Annual General Meeting.

2.6 Performance Evaluation of Board Members

Pursuant to the provisions of the Companies Act, 2013 and Listing Regulations, the Board has carried out the annual performance evaluation of its own performance, the Directors individually as well as the evaluation of its Committees. A structured parameter has been prepared after taking into consideration inputs received from the Directors, covering various aspects of the Board's functioning such as adequacy of the composition of the Board and its Committees, Board culture, execution and performance of specific duties, obligations and governance.

The performance evaluation of Independent Directors has been done by the entire Board of Directors, and on the basis of that, it was determined whether to extend or continue the term of appointment of the Independent Director.

The Board has carried out an exercise to evaluate the performance of individual Directors including the Chairman of the Board, who were evaluated on parameters such as level of engagement and contribution, independence of judgment, safeguarding the interest of the Company etc. The performance evaluation of the Directors was carried out by the entire Board except the director being evaluated. The performance evaluation was found satisfactory.

The Nomination and Remuneration Committee has formulated the criteria for evaluation of Independent Directors based on the following specifications:

- a. Participation at Board/ Committee Meetings;
- b. Managing Relationship;
- c. Knowledge and Skill;
- d. Personal Attributes;
- e. Initiative and Resourcefulness;
- f. Judgment, Adaptability & Decisiveness;
- g. Innovation and Creativity;
- h. Leadership;
- i. Interpersonal Relationship;
- j. Oral & Written Communication;
- k. Job knowledge and skills;
- l. Learning Ability & Evaluating subordinates;
- m. Self-Management etc.

2.7 Availability of Information to Board Members

The Board has unrestricted access to all Company-related information including that of our employees. At Board meetings, managers and representatives who can provide additional insights on the items being discussed are invited. Regular updates being provided to the Board include:

- Annual operating plans and budget, capital budgets and updates.
- Quarterly results of the Company
- Minutes of meeting of Audit, Nomination and Remuneration, Stakeholders Relationship, Risk Management and Corporate Social Responsibility Committees and abstracts of circular resolution passed.

- General notices of interest received from directors.
- Dividend Data including unpaid dividend figures for previous years.
- Information on recruitment and remuneration of senior officers just below the level of board of directors.
- Materially important litigations, show cause, demand and penalty notices.
- Any issues that involves possible public or product liability claims of a substantial nature.
- Significant labour problems and their proposed solutions. Any significant development involving human resource management
- Details of foreign exchange exposure and the steps taken by the management to limit risks of adverse exchange rate movement.
- Non Compliance with any regulatory, statutory or listing requirements.
- Any material default in financial obligations to and by the listed entity, or substantial non-payment for goods sold by the listed entity.

2.8 Familiarization programmes for Board Members

The Board members are provided with necessary documents/brochures, reports and internal policies to enable them to familiarise with the Company's procedures and practices. Periodic presentations are made at the Board and Committee Meetings, on business and performance updates of the Company, global business environment, business strategy and risks involved. Detailed presentations on the Company's business segments were made at the Board Meetings.

Quarterly updates on relevant statutory changes encompassing important laws are regularly circulated to the Directors. Site visits to various plant locations are organized for the Directors to enable them to understand the operations of the Company. The details of such familiarization programmes for Independent Directors are posted on the website of the Company

http://www.shivamautotech.com/Uploads/image/231imguf_DetailsofFamiliarizationProgramme.pdf

Familiarization programmes for Independent Directors

The Program aims to provide insights into the Company to enable the Independent Directors to understand its business in depth and contribute significantly to the Company.

Details of Familiarization sessions held during the FY 2020-21 pursuant to the Policy are as follows:

- Efficiency of internal controls, risk management system, strategy followed and new initiatives taken with regard to risk management.
- Relaxations from Compliance Stipulations provided by the various Statutory and Regulatory Authorities due to Globally declared Pandemic COVID-19.
- New initiatives and strategic decisions regarding Company's business and update on Emergency Credit Line Guarantee Scheme introduced by the Government of India.
- Update on the CSR Amendment Rules, 2021.
- Induction for new Director covering overview of the Munjal group and business divisions etc.

2.9 Core Skills/Expertise/Competencies of the Board of Directors

We have vibrant Board of Directors with vast range of skills, expertise and experience from various fields and sectors as required. Below is the chart of skills/expertise/competence identified by the Board of Directors in context of the Company's businesses and sectors for it to function effectively and actually available with the Board:

Name of Director	Core Skills/Expertise/Competencies
Mr. Bhagwan Dass Narang	<p>He has rich experience in banking, Finance and Taxation, Business process and improvements, Impact Investing, Commercial experience including communications, marketing, branding and business systems, practices and improvement, General Management and Strategic planning.</p> <p>He has handled special assignments viz. Chairman for the panel on Serious Financial Frauds appointed by RBI, appointed as Chairman of Governing Council of National Institute of Banking Studies & Corporate Management, Chairman of IBA's Advisory Committee.</p>
Mr. Neeraj Munjal	<p>He has a vast experience of precision and value engineering, and Project Management, Global Business Leadership, Business Development and Business Operations.</p> <p>He has been responsible for conceptualizing near net shape forging technology in Shivam Autotech Limited employing cold, warm and hot forging.</p> <p>He is proficient to lead a team of engineers to evolve solution to complex manufacturing problems. He also held Chairmanship of CII, Haryana Chapter.</p>
Mrs. Charu Munjal	<p>She has an exposure in creative designing and Sales, Marketing field and International Business, Business Development and Business Operations.</p> <p>She leads the team of marketing personnel and guides them to identify new marketing initiatives/forging strategies for new business developments and control all associated administration and system-driven operations.</p>
Dr. Anil Kumar Gupta	<p>He is a well-respected Engineer cum Scientist, capable of creating value addition and complex sub- systems / systems, having in-depth knowledge of mechanical and metallurgical engineering with special expertise in Metal Forming Processes, including technology development of light weighted materials and composites, and has technical Expertise. He held the Vice President, Materials Research Society of India (MRSI), and was also the Chairman, Materials Research Society of India, Delhi & Bhopal Chapters.</p> <p>He has guided PhD (Engineering) Scholars during his 34 years carrier in CSIR and published large number of National and International Scientific Publications.</p>
Ms. Jyothi Prasad	<p>She is an Independent consultant in the area of financial advisory services including IPOs, Mergers & Acquisitions, private Equity and fund raising, investment banking experience, expertise in business, project management and operational aspects.</p> <p>She is at present, associated as a Senior Advisor with Sparrow Advisory, a boutique provider of PE and M&A advice and is involved in their assignments from time to time.</p> <p>The organizations she has worked for include SBI Capital Markets, Peregrine Capital, NM Rothschild (India) and American Orient Capital Markets in various capacities relating to investment banking/corporate finance.</p>
Mr. Sunil Chinubhai Vakil	<p>He has rich experience in corporate finance/business consultancy, Business Restructuring, Forensic Audit & Investigative Engagements.</p> <p>He has been an accredited advisor to Central Bureau of Intelligence (CBI), a premier investigation agency in India on matters of national import involving economic crimes in cross border jurisdictions.</p> <p>He was (for 2016-2019), a Vice Chairperson of the International Committee of Technical advisors of ROTARY INTERNATIONAL that oversees, monitors and regulates the large, global grant-enabled humanitarian service projects in over 100+ countries around the world.</p>

2.10 Disclosure in terms of Regulation 34 (3) read with Schedule V Part C of SEBI (Listing Obligations and Disclosure Requirements) Regulations, 2015

There are no inter-se relationships between the Board members except Mr. Neeraj Munjal and Mrs. Charu Munjal being Spouses.

2.11 Committees of the Board

With a view to have a more focused attention on business and for better governance and accountability, committees viz. Audit Committee, Stakeholders' Relationship Committee, Nomination and Remuneration Committee, Corporate Social Responsibility Committee (*dissolved with effect from February 12, 2021, pursuant to Rule 3(2) of The Companies (Corporate Social Responsibility Policy) Rules, 2014*) and Risk Management Committee (*dissolved with effect from February 12, 2021 pursuant to Regulation 21(5) of SEBI (Listing Obligation and Disclosure Requirements), Regulations, 2015*) were constituted. The terms of reference of these Committees are determined by the Board and their relevance reviewed from time to time. Meetings of each of these Committees are convened by the respective Chairman of the Committee, who also informs the Board about the summary of discussions held in the Committee Meetings. The Minutes of the Committee Meetings are sent to the respective members of the Committees and tabled at the next consecutive Board Meeting for the noting of Board Members.

The Board of Directors had accepted all the recommendations as and when received from its Committees on different matters.

3. AUDIT COMMITTEE

Audit Committee of the Board of Directors ("the Audit Committee") is entrusted with the responsibility to supervise the Company's financial reporting process and internal controls. The composition, quorum, powers, role and scope are in accordance with Section 177 of the Companies Act, 2013 and the provisions of Regulation 18 of the Listing Regulations.

All members of the Audit Committee are financially literate and bring in expertise in the fields of Finance, Taxation, Economics, Risk and International Finance and have insight to interpret and understand financial statements. It functions in accordance with its terms of reference that defines its authority, responsibility and reporting function.

3.1 Composition of the Audit Committee and attendance of members

The Audit Committee comprises mainly of Independent Directors and the composition is in conformity with the Listing Regulations. During the Financial Year 2020-21, 4 (four) meetings of the Audit Committee were held on July 28, 2020, August 31, 2020, November 09, 2020 and February 12, 2021. The requisite quorum was present at all the Meetings. The intervening gap between the meetings was within the period prescribed under the Companies Act, 2013 read with MCA General Circular No. 11/2020 dated March 24, 2020 and Listing Regulations read with SEBI Circular SEBI/HO/CFD/CMD1/CIR/P/2020/3 dated March 19, 2020 & SEBI/HO/CFD/CMD1/CIR/P/2020/110 dated June 26, 2020 and the Secretarial Standards issued by the Institute of Company Secretaries of India.

The Board has re-constituted the Audit Committee in its meetings held on November 09, 2020 and February 12, 2021 consequent to resignation of Mr. Sunil Kant Munjal w.e.f September 24, 2020 and appointment of Mr. Sunil Chinubhai Vakil as an Additional Non-Executive and Independent Director of the Company w.e.f December 21, 2020 respectively.

Further, upon appointment of Mr. Bhagwan Dass Narang (Non-Executive & Independent Director) as the Chairman of the Company, Ms. Jyothi Prasad was appointed as the Chairperson of the Audit Committee in its meeting held on November 09, 2020. The total strength of the Audit Committee is four members out of which three are Independent directors and one is Non-executive director.

The Chairperson of the Audit Committee was present at the Annual General Meeting of the Company.

The Company Secretary acts as the Secretary of the Committee.

The Table below provides the attendance of the Audit Committee members during the FY 2020-21:

Name	Designation	Category of Directorship	No. of Meetings attended
Ms. Jyothi Prasad	Chairperson	Independent Director	4
Mr. Bhagwan Dass Narang	Member	Independent Director	4
Dr. Anil Kumar Gupta	Member	Non-Executive Director	4
Mr. Sunil Chinubhai Vakil ⁷	Member	Independent Director	1
<i>Mr. Sunil Kant Munjal</i>	Member	Independent Director	2

Mr. Sunil Kant Munjal ceased to be member of the Committee consequent to his resignation effective September 24, 2020.

3.2 Terms of Reference

The terms of reference of the Audit Committee are wide enough to cover the matters specified for the Audit Committee under Regulation 18(3) read with Part C of Schedule II of the Listing Regulations as well as Section 177 of the Companies Act, 2013 are as follows:

- (i) Oversight of the listed entity's financial reporting process and the disclosure of its financial information to ensure that the financial statement is correct, sufficient and credible;
- (ii) Recommending to the Board, the appointment, remuneration and terms of appointment of the statutory auditors.
- (iii) approval of payment to statutory auditors for any other services rendered by the statutory auditors;
- (iv) Reviewing with the management, the annual financial statements and auditor's report thereon before submission to the board for approval, with particular reference to:
 - a) Matters required to be included in the Director's Responsibility Statement to be included in the Board's Report in terms of clause (c) of sub-section (3) of Section 134 of the Companies Act, 2013.
 - b) Changes, if any, in accounting policies and practices and reasons for the same.
 - c) Major accounting entries involving estimates based on the exercise of judgement by management.
 - d) Significant adjustments made in the financial statements arising out of audit findings.
 - e) Compliance with listing and other legal requirements relating to financial statements.
 - f) Disclosure of any related party transactions.
 - g) Modified opinion(s) in the draft audit report.
- (v) Reviewing, with the management, the quarterly financial statements before submission to the board for approval;
- (vi) Reviewing, with the management, the statement of uses / application of funds raised through an issue (public issue, rights issue, preferential issue, etc.), the statement of funds utilized for purposes other than those stated in the offer document / prospectus / notice and the report submitted by the monitoring agency monitoring the utilisation of proceeds of a public or rights issue, and making appropriate recommendations to the board to take up steps in this matter;
- (vii) Reviewing and monitoring the auditor's independence and performance, and effectiveness of audit process
- (viii) Approval or any subsequent modification of transactions of the company with related parties;
- (ix) Scrutinizing inter-corporate loans and investments;

⁷ Appointed as the member of the Audit Committee w.e.f. February 12, 2021.

- (x) Considering valuation of undertakings or assets of the company, wherever it is necessary;
- (xi) Evaluating internal financial controls and risk management systems;
- (xii) Reviewing, with the management, performance of statutory and internal auditors, adequacy of the internal control systems;
- (xiii) Reviewing the adequacy of internal audit function, if any, including the structure of the internal audit department, staffing and seniority of the official heading the department, reporting structure coverage and frequency of internal audit;
- (xiv) Discussion with internal auditors of any significant findings and follow up thereon;
- (xv) Reviewing the findings of any internal investigations by the internal auditors into matters where there is suspected fraud or irregularity or a failure of internal control systems of a material nature and reporting the matter to the Board;
- (xvi) Discussion with statutory auditors before the audit commences, about the nature and scope of audit as well as post-audit discussion to ascertain any area of concern;
- (xvii) to look into the reasons for substantial defaults in the payment to the depositors, debenture holders, shareholders (in case of non-payment of declared dividends) and creditors;
- (xviii) to review the functioning of the whistle blower mechanism;
- (xix) approval of appointment of chief financial officer after assessing the qualifications, experience and background, etc. of the candidate;
- (xx) Carrying out any other function as is mentioned in the terms of reference of the audit committee;
- (xxi) Monitoring the end use of funds raised through public offers and related matters;
- (xxii) Reviewing Foreign Exchange Exposure of the Company;
- (xxiii) Review of statement of significant related party transactions, submitted by management;
- (xxiv) Reviewing management letters / letters of internal control weaknesses issued by the statutory auditors;
- (xxv) Reviewing the appointment, removal and terms of remuneration of the internal auditor;
- (xxvi) reviewing the utilization of loans and/ or advances from/investment by the holding company in the subsidiary exceeding rupees 100 crore or 10% of the asset size of the subsidiary, whichever is lower including existing loans / advances / investments;
- (xxvii) consider and comment on rationale, cost-benefits and impact of schemes involving merger, demerger, amalgamation etc., on the listed entity and its shareholders.

The Audit Committee, while reviewing the Annual Financial Statements also reviews the applicability of various Accounting Standards (AS) referred to in Section 133 of the Companies Act, 2013. The compliance of the Accounting Standards as applicable to the Company has been ensured in the preparation of the Financial Statements for the year ended March 31, 2021.

The Audit Committee bridges the gap between the Internal Auditors and the Statutory Auditors. The Statutory Auditors are responsible for performing Independent audit of the Company's Financial Statements and Company's internal financial control over financial reporting in accordance with the generally accepted auditing practices and issuing reports based on such audits, while the Internal Auditors are responsible for the internal risk controls.

Besides the above, Chief Financial Officer, the representatives of the Statutory Auditors and the Internal Auditors are also invitees to the Audit Committee Meetings. The Company follows best practices in financial reporting. The Company has been reporting on quarterly basis, the Un-audited and Audited Financial Statements as required by the Regulation 33 of the Listing Regulations. The Company's quarterly Un-audited and Audited Financial Statements are made available on the website www.shivamautotech.com.

3.3 Internal Controls and Governance Processes

The Company continuously invests in strengthening its internal control and processes. The Audit Committee along with CFO formulates a detailed plan for the Internal Auditors for the year, which is reviewed at the Audit Committee Meetings. The Internal Auditors attend the Meetings of the Audit Committee at regular basis and submit their recommendations to the Audit Committee and provide a road map for the future.

The Company has a formal system of internal control testing which examines both the design effectiveness and operational effectiveness to ensure reliability of financial and operational information and all statutory/regulatory compliances. The Company's business processes are on SAP-ERP platforms and have a strong monitoring and reporting process resulting in financial discipline and accountability.

4. NOMINATION AND REMUNERATION COMMITTEE

The "Nomination and Remuneration Committee" has been constituted as per Section 178(1) of the Companies Act, 2013 and Regulation 19 of the Listing Regulations.

During the Financial Year 2019-20, certain modifications in the policy were made and approved by the Board of Directors in their meeting held on May 27, 2019, pursuant to amendments in SEBI (LODR) Regulations, 2015. The revised Nomination and Remuneration Policy is available on the website of the Company at : http://www.shivamautotech.com/Uploads/image/163imguf_15.nrc.pdf

4.1 Terms of Reference

The constitution and terms of reference of the Committee are in consonance with the provisions of Section 178 of the Act and Regulation 19(4) read with Schedule II of Listing Regulations. The terms of reference of the NRC, include the following:

- i) to formulate criteria for determining qualifications, positive attributes and independence of a Director and recommend to the Board of Directors the Company's policies, relating to the remuneration for the Directors, Key Managerial Personnel and other employees,
- ii) to formulate criteria for evaluation of performance of Independent Directors and the Board;
- iii) to devise a policy on Board diversity;
- iv) to identify persons who are qualified to become directors and who may be appointed in senior management in accordance with the criteria laid down and recommend to the Board their appointment and removal;
- v) whether to extend or continue the term of appointment of the Independent Director on the basis of the report of performance evaluation of Independent Directors
- vi) to recommend to the Board, all remuneration, in whatever form, payable to senior management;
- vii) to ensure that the level and composition of remuneration is reasonable and sufficient to attract, retain and motivate directors of the quality required to run the company successfully;
- viii) to ensure relationship of remuneration to performance is clear and meets appropriate performance benchmarks;
- ix) to ensure remuneration to Directors, Key Managerial Personnel and Senior Management involves a balance between fixed and incentive pay reflecting short and long-term performance objectives appropriate to the working of the company and its goals;
- x) to assist the Board in fulfilling responsibilities.

4.2 Composition of the Nomination and Remuneration Committee and attendance of members

The Nomination and Remuneration Committee comprises mainly of Independent Directors. During the Financial Year 2020-21, 4 (four) meetings of the Nomination and Remuneration Committee were held on September 25, 2020, November 09, 2020, December 21, 2020 and February 12, 2021. The requisite quorum was present at all the Meetings.

The Board has re-constituted the Nomination and Remuneration Committee in its meetings held on November 09, 2020 and February 12, 2021 consequent to resignation of Mr. Sunil Kant Munjal w.e.f September 24, 2020 and appointment of Mr. Sunil Chinubhai Vakil as an Additional Non-Executive and Independent Director of the Company w.e.f December 21, 2020 respectively.

Further, pursuant to Regulation 19(2) of Listing Regulations, upon appointment of Mr. Bhagwan Dass Narang (Non-Executive & Independent Director) as the Chairman of the Company, Ms. Jyothi Prasad was appointed as the member and Chairperson of the Nomination and Remuneration Committee in its meeting held on November 09, 2020. The table below provides the composition and attendance of the Nomination and Remuneration Committee members:

Name	Designation	Category of Directorship	No. of Meetings attended
Ms. Jyothi Prasad ⁸	Chairman	Independent Director	2
Mr. Bhagwan Dass Narang	Member	Independent Director	4
Dr. Anil Kumar Gupta	Member	Non-Executive Director	4
Mr. Sunil Chinubhai Vakil ⁹	Member	Independent Director	1
<i>Mr. Sunil Kant Munjal</i>	Member	Independent Director	0

Mr. Sunil Kant Munjal ceased to be member of the Committee consequent to his resignation effective September 24, 2020.

4.3 Remuneration of Directors

A. Pecuniary relationship/transaction with Non-Executive directors

During the year under review, there was no pecuniary relationship/transaction with any Non-Executive Directors of the Company.

B. Remuneration to Non-Executive Directors (including Independent Directors)

The Non-Executive Directors are paid remuneration by way of Sitting Fees and Commission. The Non-Executive Directors do not draw any remuneration from the Company except sitting fees of Rs. 30,000/- for each meeting of the Board and Rs. 30,000/- for each meeting of the Audit Committee, Stakeholders' Relationship Committee, Nomination and Remuneration Committee, Risk Management Committee¹⁰, Corporate Social Responsibility Committee¹¹ and Independent Directors' Meeting attended by them.

However, in addition to the sitting fees, Independent Directors are entitled to remuneration by way of commission up to 0.30% p.a. of the net profits of the company or Rs.10 Lacs per annum, whichever is less for each year commencing from October 01, 2014 as approved by the shareholders through Postal Ballot conducted by the Company, the results of which was declared on December 29, 2014.

Details of Remuneration Paid to Non-Executive Directors

Name of Non-Executive Directors	Sitting fees			Commission	Total
	Board Meeting	Committee Meeting	Independent Director's Meeting		
Mr. Bhagwan Dass Narang	2,40,000	4,20,000	30,000	-	6,90,000
Dr. Anil Kumar Gupta	2,40,000	4,20,000	-	-	6,60,000
Ms. Jyothi Prasad	2,40,000	3,30,000	30,000	-	6,00,000
Mr. Sunil Chinubhai Vakil ¹²	30,000	90,000	30,000	-	1,50,000
Mr. Sunil Kant Munjal ¹³	90,000	60,000	-	-	1,50,000

⁸ Appointed as the member and Chairperson of the Nomination and Remuneration Committee w.e.f. November 09, 2020

⁹ Appointed as the member of the Nomination and Remuneration Committee w.e.f. February 12, 2021

¹⁰ Dissolved w.e.f. February 12, 2021

¹¹ Dissolved w.e.f. February 12, 2021

¹² Appointed as an Additional (Non-Executive Independent) Director w.e.f. December 21, 2020

¹³ Resigned as Independent Director w.e.f. September 24, 2020

C. Remuneration to Executive Directors

The appointment and remuneration of Executive Directors i.e. Managing Director and Whole-Time Directors is governed by the recommendation of the Nomination and Remuneration Committee, Resolutions passed by the Board of Directors and Shareholders of the Company and Agreement executed between them and the Company. The remuneration is fixed considering various parameters such as qualification, expertise, experience, prevailing remuneration in the industry and financial position of the Company. The remuneration package of Managing Director and Whole-Time Directors comprises of salary, perquisites and allowances, and contributions to Provident and other Retirement Benefit Funds as approved by the shareholders at the General Meetings. Annual increments are linked to performance and are decided by the Nomination and Remuneration Committee and recommended to the Board for approval thereof.

The remuneration policy is directed towards rewarding performance, based on review of achievements. It is aimed at attracting and retaining high caliber talent. The Nomination and Remuneration Policy as amended by the Board in its meeting held on May 27, 2019 is displayed on the Company's website viz. www.shivamautotech.com

Presently, the Company does not have a stock options scheme for its Directors.

Details of Remuneration Paid to Managing Director and Executive Directors

(Amount in Rs. Lacs)

Executive Director(s)	Salary	Commission	Perquisites & Allowances	Contribution to PF Fund	Total
Mr. Neeraj Munjal	96.00	-	80.06	11.52	187.58
Mrs. Charu Munjal	48.00	-	32.06	5.76	85.82

Notes:

- The agreement between the Company and the Managing Director is for a period of five years. Either party is entitled to terminate the Agreement by giving not less than 180 days' notice in writing to the other party.
- Commission is payable @2.00% of the net profits of the Company computed in accordance with the provisions of the Companies Act, 2013. However, Commission has not been paid to Mr. Neeraj Munjal and Mrs. Charu Munjal for the year 2020-21. There is no severance fees paid to the directors.
- Presently, the Company does not have Stock Option Scheme.

4.4 Performance Evaluation Criteria for Independent Directors:

Pursuant to the provisions of the Companies Act, 2013 and the Listing Regulations, the Board has carried out the annual evaluation of its own performance, its Committees and all Directors individually. A structured questionnaire was prepared after circulating the draft forms, covering various aspects of the Board's functioning such as adequacy of the composition of the Board and its Committees, Board culture, execution and performance of specific duties, obligations and governance. The report of performance evaluation was then discussed and noted by the Board.

The performance evaluation of the Chairman, Managing Director and Executive Directors was carried out by the Independent Directors. The Directors expressed their satisfaction with the evaluation process.

4.5 Policy for Selection and Appointment of Directors and their Remuneration

The Board has, on the recommendation of the Nomination & Remuneration Committee framed a policy for selection and appointment of Directors, Senior Management personnel and their components of remuneration. The Nomination and Remuneration Policy is displayed on the website of the Company.

5. STAKEHOLDERS' RELATIONSHIP COMMITTEE

The Stakeholders' Relationship Committee has been constituted according to Section 178(5) of the Companies Act, 2013 read with Regulation 20 of the Listing Regulations.

5.1 Composition of the Stakeholders' Relationship Committee and number of meetings held

During the Financial Year 2020-21, 4 (four) meetings of the Stakeholders' Relationship Committee were held on July 28, 2020, August 31, 2020, November 09, 2020 and February 12, 2021. The requisite quorum was present at all the Meetings. The requisite quorum was present at all the Meetings.

The Board has re-constituted the Stakeholders' Relationship Committee in its meeting held on February 12, 2021 consequent to appointment of Mr. Sunil Chinubhai Vakil as an Additional Non-Executive and Independent Director of the Company w.e.f December 21, 2020.

Further, Mr. Sunil Chinubhai Vakil (Non-Executive & Independent Director) was appointed as the member and Chairperson of the Stakeholders' Relationship Committee in the meeting held on February 12, 2021.

The composition of the Stakeholders' Relationship Committee is as follows:

Name of the Member	Designation	Category of Directorship	No. of Meetings attended
Mr. Sunil Chinubhai Vakil ¹⁴	Chairman	Independent Director	1
Ms. Jyothi Prasad	Member	Independent Director	4
Mr. Bhagwan Dass Narang	Member	Independent Director	4
Mr. Neeraj Munjal	Member	Executive Director	4
Dr. Anil Kumar Gupta	Member	Non-Executive Director	4

Compliance Officer

Ms. Samta Bajaj, Company Secretary of the Company acts as the Compliance Officer of the Company and any request / complaint can be forwarded to the Company at e-mail Id cs@shivamautotech.com.

5.2 Scope of the Committee

The Committee looks into the matters of Shareholders/ Investors grievances along with other matters listed below:

- to consider and resolve the grievances of security holders of the Company including complaints related to transfer/ transmission of shares, non-receipt of annual report, non-receipt of declared dividends, issue of new/duplicate certificates, general meetings etc.;
- to review measures taken for effective exercise of voting rights by shareholders.
- to review adherence to the service standards adopted by the Company in respect of various services being rendered by the Registrar & Share Transfer Agent;
- to review of the various measures and initiatives taken by the Company for reducing the quantum of unclaimed dividends and ensuring timely receipt of dividend warrants/annual reports/statutory notices by the shareholders of the Company;
- to consider and approve demat/ remat of shares/split/consolidation/sub-division of share certificates;
- to consider and approve issue of share certificates (including issue of renewed or duplicate share certificates), transfer and transmission of securities, etc;
- to oversee and review all matters connected with the transfer of the Company's securities;
- to carry out any other function as prescribed under the Listing Regulations, the Companies Act, 2013 and other Applicable Law as amended from time to time;
- to carry out any other duties that may be delegated to the Committee by the Board of Directors from time-to-time.

¹⁴ Appointed as the member and Chairperson of the Stakeholders' Relationship Committee w.e.f. February 12, 2021

5.3 Details of shareholders' complaints received during the FY 2020-21 and their status are as follows:

Nature of Complaints		Total Received	Total Replied / Resolved	Pending
1.	Inquiry pertaining to non-receipt of shares after transfer	1	1	-
2.	Request for issue of duplicate share certificates	0	0	-
3.	Non receipt of dividend / Revalidation of dividend warrants	0	0	-
4.	Communication relating to Transfer / Transmission / Name Deletion / Demat of Shares	0	0	-
5.	Miscellaneous i.e. Credit of Shares in Demat A/c's, non-receipt of Annual Report, Change of Address, Bank Details, etc.	0	0	-

The Company and the Registrar and Transfer Agent, MCS Share Transfer Agent Limited attend to all grievances of the shareholders received directly or through SEBI (SCORES), Stock Exchanges, Ministry of Corporate Affairs, Registrar of Companies, etc.

Continuous efforts are made to ensure that grievances are more expeditiously redressed to the complete satisfaction of the investors. Shareholders are requested to furnish their updated telephone numbers and e-mail addresses to facilitate prompt action.

6. CORPORATE SOCIAL RESPONSIBILITY COMMITTEE

The Corporate Social Responsibility Committee (CSR) has been constituted according to Section 135 of the Companies Act, 2013.

6.1 Composition of the Corporate Social Responsibility Committee and number of meetings held:

CSR Committee has met 1 (one) time during the financial year 2020-21 on the following date i.e. July 28, 2020. The composition of the Corporate Social Responsibility Committee and details of the meetings attended by its members are given below. The requisite quorum was present at the Meeting.

Name	Designation	Category of Directorship	Attendance out of 3 meeting held
Dr. Anil Kumar Gupta	Chairman	Non-Executive Director	1
Mr. Bhagwan Dass Narang	Member	Independent Director	1
Mrs. Charu Munjal	Member	Executive Director	1

6.2 Terms of Reference

- Formulate and recommend to the board, a Corporate social responsibility (CSR) policy which shall indicate the activities to be undertaken by the Company;
- Recommend the amount of expenditure to be incurred on the activities referred to above;
- Monitor the CSR policy of the Company from time to time;
- Undertake projects/ initiatives resulting in enhancement in the quality of life and economic well-being of the community, in and around society at large.

The disclosures as per Rule 8 of the Companies (Corporate Social Responsibility Policy) Rules, 2014 is annexed herewith as an **Annexure - G** to this Report in the prescribed format.

Further, pursuant to Rule 3(2) of The Companies (Corporate Social Responsibility Policy) Rules, 2014, the Corporate Social Responsibility Committee of the Board has been dissolved with effect from February 12, 2021 but the company is still committed in contributing towards various social projects and institutions for the welfare and betterment of society. Thus, the existing members of the Corporate Social Responsibility Committee are hereby relieved from their duties of the Committee.

7. RISK MANAGEMENT COMMITTEE

The Board of the Company has formed a risk management committee to frame, implement and monitor the risk management plan for the Company. The composition of the Committee is in conformity with the Listing Regulations, with majority of members being Directors of the Company.

The committee is responsible to assist Board in fulfilling its responsibilities with regards to the identification, evaluation and mitigation of operational, strategic and environmental risks. The Committee has the overall responsibility of monitoring and approving the risk policies and associated practices of the Company. Major risks identified by the businesses and functions are systematically addressed through mitigating actions on a continuing basis.

7.1 Composition of the Risk Management Committee and attendance of members

During the financial year 2020-21, 1 (one) meeting of the Risk Management Committee was held on July 28, 2020. The requisite quorum was present at the meeting.

The Composition of the Risk Management Committee and details of the meetings attended by its members are given below:

Name	Designation	Category of Directorship	No. of Meetings attended
Dr. Anil Kumar Gupta	Chairman	Non-Executive Director	1
Mr. Bhagwan Dass Narang	Member	Independent Director	1
Ms. Jyothi Prasad ¹⁵	Member	Independent Director	1

7.2 Terms of Reference

The terms of reference of the Risk Management Committee are as follows:

1. To ensure that all the current and future material risk exposures of the company are identified, assessed, quantified, appropriately mitigated, minimized and managed i.e to ensure adequate systems for risk management;
2. To establish a framework for the company's risk management process and to ensure its implementation;
3. To monitor and oversee implementation of the risk management policy, including evaluating the adequacy of risk management systems;
4. To enable compliance with appropriate regulations, wherever applicable, through the adoption of best practices;
5. To keep the board of directors informed about the nature and content of its discussions, recommendations and actions to be taken;
6. To assure business growth with financial stability;
7. Any other matter which may be considered from time to time.

Further, pursuant to Regulation 21(5) of SEBI (Listing Obligation and Disclosure Requirements), Regulations, 2015, the Company has dissolved the Risk Management Committee with effect from February 12, 2021, and the Risk Management System/policy of the Company is now to be looked after by the Audit Committee.

Thus, the existing members of the Risk Management Committee are hereby relieved from their duties of the Committee.

8. INDEPENDENT DIRECTORS' MEETING

During the year under review, the Independent Directors met on February 12, 2021, inter alia, to:

- Evaluate performance of Non-Independent Directors and the Board of Directors as a whole;
- Evaluate performance of the Chairman of the Company, taking into account the views of the Executive and Non-Executive Directors;
- Evaluation of the quality, content and timeliness of flow of information between the Management and the Board that is necessary for the Board to effectively and reasonably perform its duties.

¹⁵ Appointed as an Additional (Non-Executive Independent) Director w.e.f. December 21, 2020

The details of the meetings attended by Independent Directors are given below:

Name	Designation	Category of Directorship	No. of Meetings attended
Mr. Bhagwan Dass Narang	Chairman	Independent Director	1
Ms. Jyothi Prasad	Member	Independent Director	1
Mr. Sunil Chinubhai Vakil ¹⁶	Member	Independent Director	1

9. RELATED PARTY TRANSACTIONS (RPT)

All transactions entered into with related parties, as defined under the Companies Act, 2013 and Regulation 23 of the Listing Regulations, during the financial year under review were in the ordinary course of business and on arm's length pricing basis. The omnibus approval of the Audit Committee has been accorded to the Company to enter into contract / arrangement for sale / purchase / services including loan transactions etc. with the related parties on arm's length basis in the meeting held **on July 28, 2020**.

Further, pursuant to **SEBI Circular SEBI/HO/CFD/CMD1/CIR/P/2020/38 dated March 19, 2020, read with SEBI Circular SEBI/HO/CFD/CMD1/CIR/P/2020/106 dated June 24, 2020** pertaining to further extension of time for submission of financial results for the quarter/half year/financial year ending 31st March 2020 **upto July 31, 2020** due to the continuing impact of the CoVID-19 pandemic, a meeting of the Board of Directors and members of the Audit Committee of the Company was held on 28th day of July, 2020 in which the omnibus approval to enter into contract / arrangement for sale / purchase / other services including loan transactions etc. with the related parties on arm's length basis, was taken.

Further, the Board has also ratified the related party transactions entered into by the Company during period between April 01, 2020 to July 27, 2020 as per the details placed before the Board.

10. GENERAL BODY MEETINGS

a) Annual General Meeting

Date, time and location where the last three Annual General Meetings were held, are as under:

Year	Date	Venue	Time	Whether Special resolution passed in previous AGM
2017-18	29.09.2018	Tivoli Garden Resort, Near Chattarpur Mandir, Chattarpur Road, New Delhi-110074	11:30 A.M.	-
2018-19	25.09.2019	Club Nirvana Patio, Block-K, Nirvana Country, Sector 50, Gurugram - 122018, Haryana	12:00 Noon	1. Re-appointment of Mr. Sunil Kant Munjal (DIN 00003902) as an Independent Director of the Company. 2. Re-appointment of Mr. Bhagwan Dass Narang, (DIN 00826573) as an Independent Director of the Company. 3. Approval for payment of minimum remuneration to Executive Directors.
2019-20	30.09.2020	Deemed Venue-Shivam Autotech Limited, 10, 1 st Floor, Emaar Digital Greens, Tower A, Sector 61, Golf Course Extension Road, Gurugram, Haryana-122102	11:30 A.M. through Video Conferencing ("VC") / Other Audio Visual Means ("OAVM")	1. Conversion of unsecured Loans into equity Shares of the Company.

¹⁶ Appointed as an Additional (Non-Executive Independent) Director w.e.f. December 21, 2020

(b) Resolutions passed last year through Postal Ballot:

During the financial year 2020-21, no Special Resolution was passed through Postal Ballot and as on date, no Special Resolution is proposed to be conducted through Postal Ballot.

(c) Extraordinary General Meeting (EGM)

No EGM was held during the Financial Year 2020-21.

11. MEANS OF COMMUNICATION

- a. The Company interacts with its Investors through multiple forms of corporate and financial communications such as annual reports, result announcements and media releases. The Quarterly/half yearly/nine months/ Annual Financial Results of the Company are uploaded on NSE Electronic Application Processing System (NEAPS) and BSE Listing in accordance with the Listing Regulations, immediately after these are approved by the Board. The Quarterly/half yearly/nine months/Annual Financial results are also published within forty-eight hours in widely circulating national and local newspapers such as the Business Standard in English and Business Standard in Hindi.
- b. The Company's results are displayed on the Company's website i.e. www.shivamautotech.com. The website also displays the compliances done pursuant to Listing Regulations.

SEBI vide Circular No. SEBI/HO/CFD/CMD1/ CIR/P/2020/38 dated March 19, 2020 and Circular No. SEBI/HO/DDHS/ON/P/2020/41 dated March 23, 2020 had extended the timeline for submission of financial results under Regulation 33 of the SEBI (Listing Obligations and Disclosure Requirements) Regulations, 2015 to June 30, 2020 and further extended the timeline for submission of financial results under Regulation 33 of the Listing Regulations till July 31, 2020 vide Circular No. SEBI/HO/CFD/CMD1/CIR/P/2020/106 dated June 24, 2020.

The Company also informs by way of intimation to BSE and NSE all price sensitive information or such other matters, which in its opinion are material and of relevance to the members.

In compliance with the Listing Regulations, the quarterly financial results, shareholding pattern, quarterly compliances and all other corporate communication to the Stock Exchanges viz. BSE Limited and the National Stock Exchange of India Limited (NSE) are filed electronically on BSE's online portal through website www.listing.bseindia.com and with NSE through NSE Electronic Application Processing System ('NEAPS') portal.

No presentations were made to the institutional investors or to the analysts.

12. GENERAL SHAREHOLDER INFORMATION**12.1 Annual General Meeting**

The ensuing Annual General Meeting will be held on Wednesday, September 29, 2021 at 12:00 Noon through video conferencing or other audio visual means for which purpose the Registered Office of the Company situated at 10, 1st Floor, Tower A, Emaar Digital Greens, Sector – 61, Golf Course Extension Road, Gurugram, Haryana – 122102 shall be deemed as the venue for the Meeting.

12.2 Financial Calender for FY 2021 – 2022

Financial Year - April 1 to March 31

- i) First Quarter Results – on or before August 14, 2021
- ii) Second Quarter Results – on or before November 14, 2021
- iii) Third Quarter Results – on or before February 14, 2022
- iv) Fourth Quarter Results – on or before May 30, 2022
- v) Audited Results for the year ended March 31, 2022 – on or before May 30, 2022
- vi) Annual General Meeting for the year ended March 31, 2022 – on or before September 30, 2022

12.3 Dates of Book Closure

Monday, September 20, 2021 to

Wednesday, September 29, 2021 (both days inclusive)

12.4 Listing on Stock Exchanges

The BSE Limited

The National Stock Exchange of India Limited

The Annual Listing Fees for 2021-22 have been paid to both the Stock Exchanges.

12.5 Stock Code

532776 – The BSE Limited

SHIVAMAUTO – The National Stock Exchange of India Limited

12.6 Company Identification Number (CIN): L34300HR2005PLC081531 (w.e.f. July 18, 2019)

Permanent Account Number (PAN): AAJCS7372M

Face value of the Equity Share: Rs.2/- per share

12.7 Details of Public Funding obtained in the previous three years: The Company has not obtained any public funding in the previous three years.**12.8 Demat ISIN Number for NSDL and CDSL**

INE637H01024

12.9 Market Price Data

The **monthly** high and low quotations as well as the volume of shares traded on the BSE Limited (BSE) and National Stock Exchange of India Limited (NSE) are as follows:

Month	BSE Limited (BSE)				National Stock Exchange (NSE)			
	High (Rs.)	Date	Low (Rs.)	Date	High (Rs.)	Date	Low (Rs.)	Date
Apr'2020	12.90	13-Apr-20	9.20	1-Apr-20	12.85	13-Apr-20	9.20	1-Apr-20
May'2020	11.34	29-May-20	10.17	12-May-20	11.30	29-May-20	10.05	18-May-20
Jun'2020	19.05	10-Jun-20	11.85	1-Jun-20	18.95	10-Jun-20	11.65	1-Jun-20
Jul'2020	17.40	01-Jul-20	12.50	31-Jul-20	17.00	01-Jul-20	12.55	31-Jul-20
Aug'2020	20.14	28-Aug-20	12.25	03-Aug-20	20.65	28-Aug-20	12.95	03-Aug-20
Sep'2020	19.40	07-Sep-20	14.70	29-Sep-20	19.50	04-Sep-20	14.90	29-Sep-20
Oct'2020	19.35	26-Oct-20	15.30	01-Oct-20	19.10	26-Oct-20	15.30	01-Oct-20
Nov'2020	22.55	27-Nov-20	16.20	05-Nov-20	22.50	27-Nov-20	16.30	05-Nov-20
Dec'2020	23.80	18-Dec-20	19.55	30-Dec-20	23.95	18-Dec-20	19.45	30-Dec-20
Jan'2021	23.65	13-Jan-21	19.4	01-Jan-21	23.70	13-Jan-21	19.80	27-Jan-21
Feb'2021	23.00	05-Feb-21	20.00	03-Feb-21	23.20	05-Feb-21	19.95	03-Feb-21
Mar'2021	21.40	04-Mar-21	17.00	26-Mar-21	21.40	01-Mar-21	17.00	26-Mar-21

12.10 Performance in comparison to broad-based indices

The Charts below depicts the comparison of monthly Company's share price with BSE SENSEX and NIFTY 50:

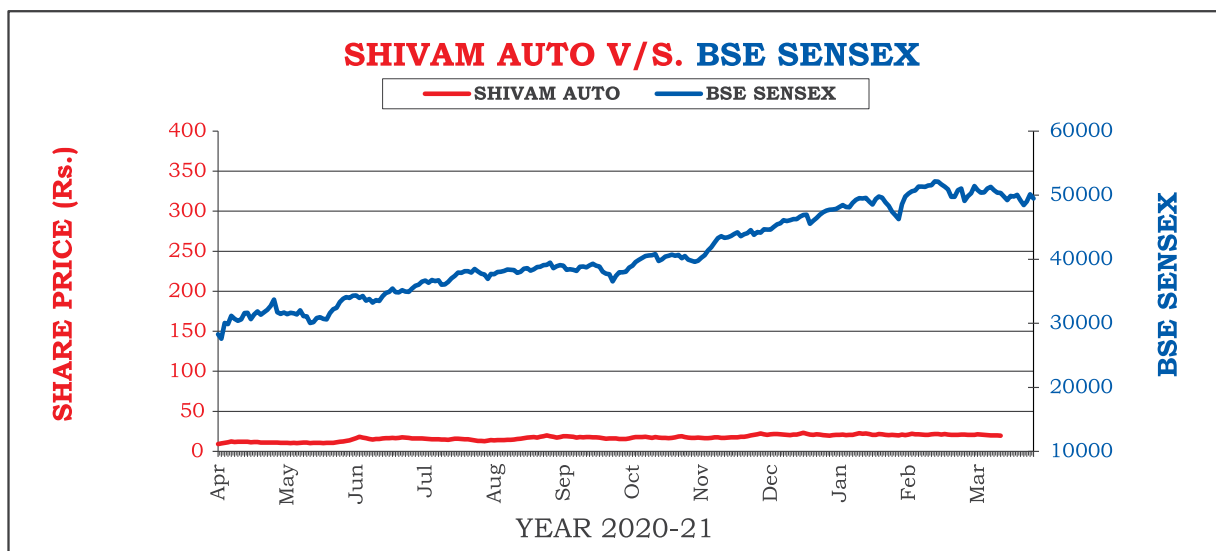
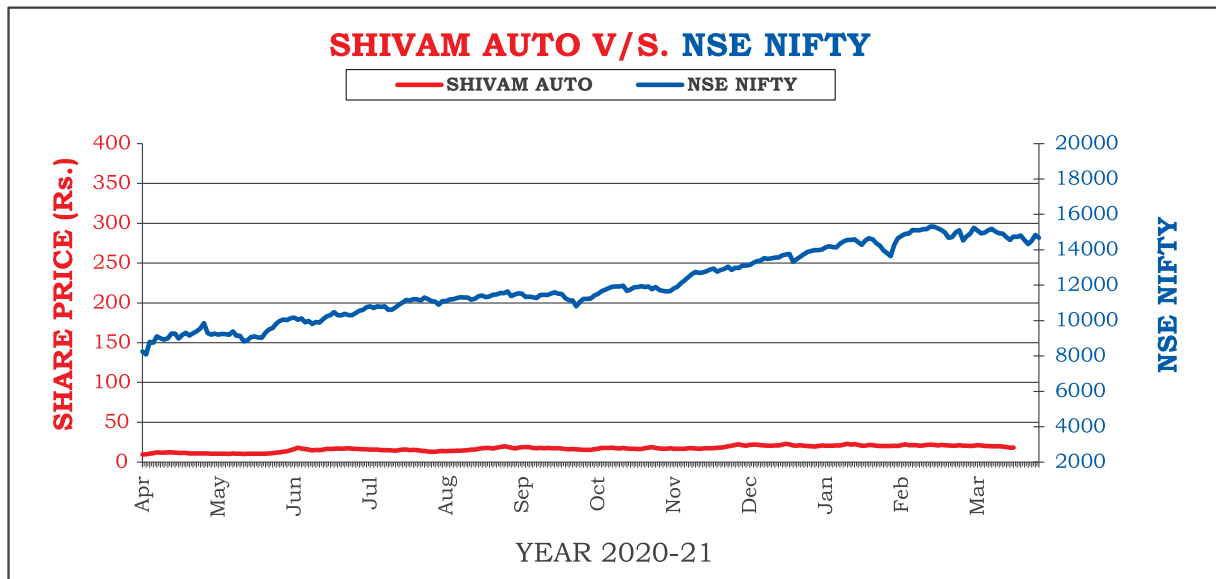

12.11 Registrar and Transfer Agent

Share transfers and other communication regarding change of address, dividends, share certificates, investor complaints, etc. may be addressed to

MCS Share Transfer Agent Limited
F-65, 1st Floor, Phase-I, Okhla Industrial Area
New Delhi-110 020
Tel: 011-41406149-52
Fax No: 011-41709881
E-mail: admin@mcsregistrars.com

Members are requested to ensure that correspondence for change of address, change in bank details, processing of unclaimed dividend, sub-division of shares, renewals / split / consolidation of share certificates, issue of duplicate share certificates should be signed by the first named Member as per the specimen signature registered with the Company. The Company may also, with a view to safeguard the interest of its Members and that of the Company, request for additional supporting documents such as certified copies of PAN Cards and other proof of identity and/ or address. Members are requested to indicate their Ledger Folio number in their correspondence with the Company and also to provide their email addresses and telephone numbers/FAX numbers to facilitate prompt response from the Company.

Members who hold shares in dematerialized form should correspond with the Depository Participant with whom they maintain Demat Account/s, for their queries relating to shareholding, change of address etc. However, queries relating to non-receipt of dividend, non-receipt of annual reports, or on matters relating to the working of the Company should be sent to the Company.

Nomination Facility

The Company offers facility of nomination. The facility is made available folio-wise and for the entire shares registered under the folio. The members holding shares in dematerialized form may contact and consult their respective Depository Participant (DP) for availing the nomination facility. Members holding shares in physical form may contact Registrar & Transfer Agent (RTA) of the Company.

12.12 Distribution of Shareholding as on March 31, 2021

No. of shares held	No. of shareholders		No. of shares	
	Numbers	%	Numbers	%
Up to 500	20152	73.78	3,602,754	3.60
501 – 1000	3309	12.11	2,845,029	2.85
1001 – 2000	1750	6.41	2,738,779	2.73
2001 – 3000	795	2.91	2,040,435	2.04
3001 – 4000	308	1.13	1,120,131	1.12
4001 – 5000	387	1.42	1,865,588	1.87
5001 – 10000	376	1.38	2,807,511	2.81
10001 – 50000	201	0.74	3,823,232	3.82
50001 – 100000	20	0.07	1,416,426	1.42
100001 & above	16	0.06	77,740,115	77.74
Total	27,314	100.00	100,000,000	100.00

Shareholding pattern as on March 31, 2021

S. No.	Categories	No. of Holders	No. of Shares	% Shareholding
A	Promoter Holding			
I	Dayanand Munjal Investments Private Limited	1	74,795,950	74.80
	Total Promoter Holding	1	74,795,950	74.80
B	Public Holding			
	<i>Institutions</i>			
I	Mutual Funds	3	18,984	0.02
II	Banks/Financial Institutions	1	3,000	0.00
	Sub Total	4	21,984	0.02
	<i>Non Institutions</i>			
I	Individuals			
	Individuals holding nominal share capital upto Rs. 2 Lacs	26,112	20,897,008	20.90
	Individuals holding nominal share capital in excess of Rs. 2 Lacs	12	1,796,313	1.80
lii	Others:			
	a. Other Bodies Corporate	188	1,349,813	1.35
	b (i). NRI with Repat	197	441,234	0.44
	b (ii). NRI without Repat	107	432,466	0.43
	d. Cooperative Societies	1	6,000	0.01
	e. Trust	1	1,250	0.00
	f. Govt - IEPF Suspense Account	1	257,982	0.25
	Sub Total	26,619	25,182,066	25.18
	Total Public Holding	26,623	25,204,050	25.20
	Grand Total	26,624	100,000,000	100.00

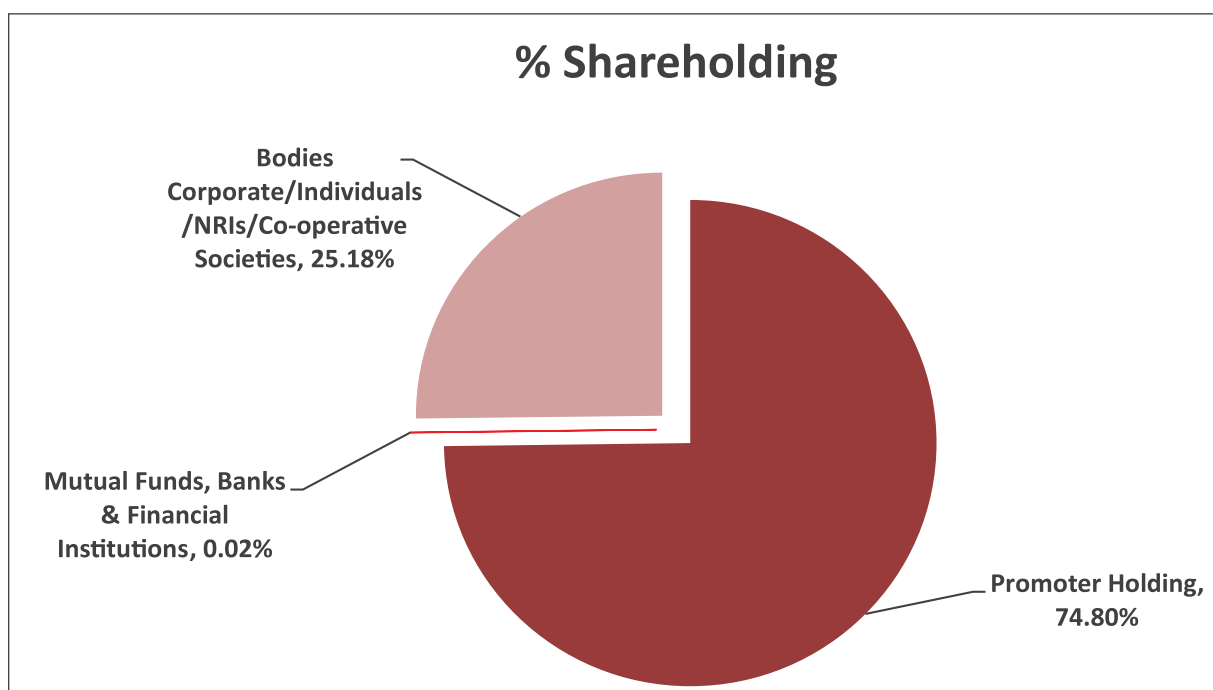

12.13 Share Transfer System

SEBI has mandated that, effective April 1, 2019, no share can be transferred in physical mode. Hence, the Company has stopped accepting any fresh lodgement of transfer of shares in physical form. The Company had sent communication to the shareholders encouraging them to dematerialise their holding in the Company. The communication, inter alia, contained procedure for getting the shares dematerialised. Shareholders holding shares in physical form are advised to avail the facility of dematerialisation.

The Stakeholders' Relationship Committee is authorized to approve issuance of duplicate certificates and all such issuance are completed within statutory time limit from the date of request, provided the documents meet the stipulated requirement of statutory provisions in all respects. The documents received from shareholders are scrutinized by the Company's RTA and all work related to share registry, is handled by RTA. In compliance of the provisions of SEBI Listing Regulations, the share transfer system of the Company is audited every six months by a Practicing Company Secretary and a certificate to that effect is issued by him.

The Board of Directors has delegated the authority to approve the share transfers/transmissions etc. to the Company Secretary who attend the same within the prescribed period and in case of any dispute / difference, forward the same to the Stakeholders' Relationship Committee for their approval.

12.14 Dematerialisation of Shares and Liquidity

The process of conversion of Shares from physical form to electronic form is known as dematerialisation. For dematerializing the shares, the Shareholder has to open a demat account with a Depository Participant (DP). The Shareholder is required to fill in a Demat Request Form and submit the same alongwith the Share Certificate(s) to the DP. The DP will allocate a demat request number and shall forward the request physically and electronically, through NSDL/CDSL to the RTA. On receipt of the demat request, both physically and electronically and after verification, the Shares are dematerialised and an electronic credit of Shares is given in the account of the Shareholder.

The Company has arrangements with National Securities Depository Ltd. (NSDL) as well as the Central Depository Services (India) Ltd. (CDSL) for demat facility. As on March 31, 2021, 98.58% of the total Equity Capital is held in the demat form with NSDL and CDSL.

Physical and Demat Shares:

	As on March 31, 2021	%
No. of Shares held by NSDL	89,347,719	89.35
No. of Shares held by CDSL	9,254,651	9.25
Physical Shares	1,397,630	1.40
TOTAL	100,000,000	100.00

12.15 Outstanding GDRs / ADRs / Warrants or any Convertible Instruments, Conversion Date and likely impact on Equity

Not Issued

12.16 Foreign Exchange Risk and Commodity Hedging Activities

During the year under review, the Company has no fully hedged Letters of credit in foreign currency for Imports of some raw materials, stores & spares and capital goods. The Company may consult banks for hedging /booking the import bill to manage the foreign exchange risks.

12.17 Plant Locations with address

- **Binola Plant** – 58 Km Stone, Delhi - Jaipur Highway, Village - Binola, Gurugram – 122413, Haryana.
- **Haridwar Plant** - Plot No. 3, Industrial Park 2, Phase I, Village Salempur, Tehsil Mehdood, Haridwar - 249401, Uttarakhand.
- **Bengaluru Plant** - Plot No. 98, Vemagal Industrial Area, Kolar – 563101, Karnataka.
- **Rohtak Plant** - Plot No. 9, Sector-30A, IMT Rohtak, District: Rohtak -124001, Haryana.

12.18 Address for correspondence

Ms. Samta Bajaj
 Company Secretary
 10, 1st Floor, Emaar Digital Greens, Tower A,
 Sector-61, Golf Course Extension Road, Gurugram,
 Haryana-122102
 Tel. No.: 0124-4698700
 Fax: - 0124-4698798
cs@shivamautotech.com

Queries relating to the Financial Statements of the Company may be addressed to-

Mr. Krishan Gopal Gupta
 DGM-Finance
 10, 1st Floor, Emaar Digital Greens, Tower A,
 Sector-61, Golf Course Extension Road, Gurugram,
 Haryana-122102
 Tel. No.: 0124-4698700
 Fax: - 0124-4698798
krishan@shivamautotech.com

1.19 Credit Rating

For our bank facilities and other debt programs CARE has provided us a long-term rating of 'CARE D' and a short-term rating of 'CARE D'.

1.20 Compliance with Secretarial Standards

The Institute of Company Secretaries of India, a Statutory Body, has issued Secretarial Standards on Board and General meetings. The Company has complied with all the applicable provisions of the Secretarial Standards on Board and General meetings.

1.21 Secretarial Audit

- a) Satyender Kumar & Associates, Company Secretaries have conducted a Secretarial Audit of the Company for the year 2020-21. Their Audit Report (except observations, remarks, qualifications as stated in the report) confirms that the Company has complied with the applicable provisions of the Companies Act, 2013 and the Rules made there under, Listing Agreements with the Stock Exchanges, applicable Listing Regulations and other laws applicable to the Company. The Secretarial Audit Report forms part of the Board's Report.

- b) Pursuant to Regulation 40(9) of the Listing Regulations, certificates have been issued on a half-yearly basis, by Satyender Kumar & Associates, Company Secretaries, certifying due compliance of share transfer/transmission formalities by the Company.

12.22 Reconciliation of Share Capital Audit

As stipulated by SEBI, Satyender Kumar & Associates, Company Secretaries conducts the Reconciliation of Share Capital Audit of the Company for the purpose of reconciliation of total admitted capital with the depositories, i.e. NSDL and CDSL, and the total issued and listed capital of the Company.

Satyender Kumar & Associates, Company Secretaries conducts such audit in every quarter and issues a Reconciliation of Share Capital Audit Certificate to this effect to the Company. A copy of such audit report is submitted to the stock exchanges, where the Company's shares are listed and is also placed before the Board.

12.23 Unclaimed dividend

In terms of Section 124(5) of the Companies Act, 2013 ("Act") if a member does not claim the dividend amount for a consecutive period of seven years or more, the unclaimed amount shall be transferred to the Investor Education and Protection Fund (IEPF) established by the Central Government.

During the year, the Company has transferred Rs. 7,74,968/- lying unclaimed in Unpaid Dividend Account in respect of Dividend for the year 2012-13 to the said Fund on November 19, 2020.

13. DISCLOSURES

13.1 All transactions entered into with related parties as defined under the Act and Regulation 23 of the Listing Regulations during the Financial Year 2020-21 were in the ordinary course of business and on arm's length pricing basis and do not attract provisions of Section 188 of the Act. There were no materially significant transactions with the related parties during the Financial Year which were in conflict with the interest of Company. Suitable disclosures as required by Accounting Standard (AS 18) have been made in the Financial Statements.

13.2 Strictures and Penalties

The Company has complied with the requirements of the Stock Exchanges/ SEBI and Statutory Authorities on all matters related to the capital markets during the last three years. No other penalties have been imposed or strictures passed against the Company by the stock exchanges, the Securities and Exchange Board of India or any statutory authority on any matter related to capital markets during the last three years. Further, Securities of the Company have not been suspended for trading at any point of time during the year.

13.3 Vigil mechanism / Whistle Blower Policy

The Company is committed to adhere to the highest standards of ethical, moral and legal conduct of business operations. To maintain these standards, the Company encourages its employees who have concerns about suspected misconduct to come forward and express these concerns without fear of punishment or unfair treatment. A Vigil mechanism / Whistle Blower Policy as defined under Regulation 22 of the Listing Regulations provides a channel to the employees and Directors of the Company to report to the management concerns about unethical behaviour, actual or suspected fraud or violation of the codes of conduct or policy. The mechanism provides for adequate safeguards against victimization of employees and Directors of the Company to avail the mechanism and also provide for direct access to the Managing Director/Chairman of the Audit Committee in exceptional cases. This neither relieves employees from their duty of confidentiality in the course of their work nor can it be used as a route for raising malicious or unfounded allegations against people in authority and / or colleagues in general.

None of the personnel of the Company has been denied access to the Audit Committee.

Name and Address of the Vigilance & Ethics Officer

Mr. Anshuman Sharma (AGM-HR&A)
Shivam Autotech Limited
10, 1st Floor, Emaar Digital Greens, Tower A,
Golf Course Extension Road, Gurugram, Haryana-122102
0124-4698700
E-mail- anshumansharma@shivamautotech.com

Name and Address of Managing Director

Mr. Neeraj Munjal
 Shivam Autotech Limited
 10, 1st Floor, Emaar Digital greens, Tower A,
 Golf Course Extension Road, Gurugram, Haryana-122102
 0124-4698700
 Email- neeraj@shivamautotech.com

Name and Address of the Chairman of Audit Committee

Ms. Jyothi Prasad
 Shivam Autotech Limited
 10, 1st Floor, Emaar Digital greens, Tower A,
 Golf Course Extension Road, Gurugram, Haryana-122102
 0124-4698700
 Email- admn@shivamautotech.com

Pursuant to Section 177 of the Companies Act, 2013, the SEBI Listing Regulations and the SEBI (Prohibition of Insider Trading) Regulations, 2015, the Company had adopted its Whistle Blower Policy. The website link of Vigil Mechanism / Whistle Blower Policy is given below:

<http://www.shivamautotech.com/pdf/WhistleBlowerPolicy.pdf>

- 13.4 The Company has complied with the mandatory requirements specified in Listing Regulations relating to Corporate Governance.

13.5 Material Subsidiaries

The Company does not have any material subsidiary.

- 13.6 The Board has approved a policy for related party transactions which can be accessed at the Company's website link http://www.shivamautotech.com/Uploads/image/161imguf_6.rpt.pdf

- 13.7 The Company is not exposed to commodity price risks and commodity hedging activities.

13.8 Details of utilization of funds raised through preferential allotment or qualified institutions placement as specified under Regulation 32 (7A)

The Company has not raised funds through preferential allotment or qualified institutions placement during the year.

13.9 Certificate from Practising Company Secretary

The Company has received a certificate from a Practising Company Secretary to the effect that none of the directors on the Board of the Company has been debarred or disqualified from being appointed or continuing as directors of the Company by the Ministry of Corporate Affairs or any other statutory authority. The same is attached as **Annexure-F** which forms part of this report.

13.10 Audit Fees paid to Statutory Auditors

The details of total fees for all services paid to the Statutory Auditors M/S. NSBP & Co., Chartered Accountants (Firm Registration No.001075N) during the year ended March 31, 2021 are as below:

Particulars	Amount (Rs. In Lakhs)
Audit Fees	10.50
Limited reviews	4.50
Certifications/other services	4.00
Total	19.00

13.11 Policy to prevent and deal with sexual harassment

The Company has in place a policy on Prevention of Sexual Harassment at workplace. For further details in this regard, please refer to the Board's Report forming part of this Annual Report.

13.12 Unclaimed / Undelivered Shares to Suspense Account

In terms of Regulation 39 of the Listing Regulations, the Company reports the following details in respect of equity shares lying in the Unclaimed Suspense Account which were issued in demat form:

Particulars	Demat	
	Number of Shareholders	Number of equity shares
Aggregate Number of shareholders and the outstanding shares in the Suspense Account lying as on April 01, 2020	1,369	766,370
Number of shareholders who approached the Company for transfer of shares and shares transferred from Suspense Account during the year	2	500
Aggregate Number of shareholders and the outstanding shares in the Suspense Account lying as on March 31, 2021	1,367	765,870

The voting rights on the shares in the suspense account shall remain frozen till the rightful owners claim the shares.

13.13 Transfer of Unpaid / Unclaimed Amounts and Shares to Investor Education and Protection Fund

Pursuant to the provisions of Section 124(6) of the Companies Act, 2013 ("Act") read with Rule 6 of Investors Education and Protection Fund Authority (Accounting, Audit, Transfer and Refund) Rules, 2016 (as amended from time to time) ("Rules"), members whose dividend amount has not been paid or claimed for seven consecutive years or more, shares held by them shall be credited to the demat Account of the Investor Education and Protection Fund Authority (IEPFA). During FY 2020-21, 3,282 equity shares of Rs. 2/- each held by aforesaid members, were transferred to the demat Account of IEPF Authority constituted in accordance with the Rules.

These details have also been uploaded on the website of the IEPF Authority (www.iepf.gov.in). All the corporate benefits accruing on these shares like bonus, splits etc. also will be credited to the said "Demat Account" of the IEPF Authority and the voting rights on these shares shall remain frozen until the rightful owner has claimed the shares.

The Company has initiated necessary action for transfer of shares in respect of which dividend has not been paid or claimed by the members consecutively since 2013-14. During the financial year 2021-22, notices were sent to the concerned shareholders whose shares were liable to be transferred to IEPF Demat Account under the said Rules for taking appropriate action and full details of such shareholders and shares due for transfer to IEPF Authority's Demat Account have also been uploaded on Company's website at www.shivamautotech.com.

13.14 Prevention of Insider Trading

The Company has adopted a Code of internal procedures and Conduct for regulating, monitoring and reporting of trading by designated persons with a view to regulate trading in securities by the designated persons of the Company applicable from April 01, 2019 as per SEBI (Prohibition of Insider Trading) (Amendment) Regulations, 2019. This Code is applicable to all Board Members / Officers / Designated Employees. The Code requires pre-clearance for dealing in the Company's shares and prohibits the purchase or sale of Company shares by the designated persons while in possession of unpublished price sensitive information in relation to the Company and during the period when the trading window is closed.

The Company has also adopted a Code of Practice and Procedure for Fair Disclosure of Unpublished Price Sensitive Information in pursuance of Regulation 8(1) of the SEBI (Prohibition of Insider Trading) Regulation, 2015. The Chief Financial Officer of the Company is designated as Chief Investor Relations Officer in pursuance of such code. The Company Secretary is responsible for implementation of the Code.

13.15 Code of Conduct for Directors and Senior Management Personnel

The Company has in place a comprehensive Code of Conduct ('the Code') applicable to the Directors and Senior Management Personnel. The Company's Board of Directors and Senior Management Personnel are responsible for and are committed to setting the standards of conduct contained in this Code and for updating these standards, as appropriate, to ensure their continuing relevance, effectiveness and responsiveness to the needs of investors and all other stakeholders as also to reflect corporate legal and regulatory developments.

The Code is applicable to Non-Executive Directors including Independent Directors to such an extent as may be applicable to them depending on their roles and responsibilities. The Code gives guidance and support needed for ethical conduct of business and compliance of law. The Code reflects the core values of the Company viz. Customer Value, Ownership Mindset, Respect, Integrity, One Team and Excellence. A copy of the Code has been put up on the Company's website and can be accessed at:

http://www.shivamautotech.com/pdf/Code_of_Conduct_for_Board_Members_and_Senior_Management.pdf

The Code has been circulated to Directors and Management Personnel, and its compliance is affirmed by them annually. A declaration signed by the Managing Director of the Company is published in this Report.

13.16 Review of legal compliance reports under SEBI Listing Regulations

The Board periodically reviews compliance reports with respect to the various laws applicable to the Company, as prepared and placed before it by the Management.

13.17 Compliances by the Company

The Company has duly complied with Corporate Governance requirements as specified under Regulation 17 to 27, Regulation 46 (2) clause (b) to (i) and Schedule V of the Listing Regulations.

Quarterly reports on compliance with Corporate Governance as per Regulation 27 of the Listing Regulations were duly filed with the stock exchanges within the stipulated time and same are also available on website of the Company.

13.18 Compliance certificate from practicing company secretary regarding compliance of conditions of corporate governance

In compliance with Regulation 34 and Schedule V of Listing Regulations, Company has received a Certificate from Practicing Company Secretary, Satyender Kumar & Associates, Company Secretaries on compliance of the Corporate Governance norms. The same forms part of this report.

13.19 Chairman

The Company has appointed Mr. Bhagwan Dass Narang as the Chairman of the Company w.e.f. November 09, 2020. He is a Non-executive and Independent Director of the Company.

Mr. Neeraj Munjal is the Managing Director of the Company.

13.20 CEO & MD / CFO Certification

The MD and the CFO have issued certificate pursuant to Regulation 17(8) of Listing Regulations certifying that the financial statements do not contain any untrue statement and these statements represent a true and fair view of the Company's affairs for the financial year ended March 31, 2021. The said certificate forms integral part of the Annual Report.

13.21 Public Issues/Preferential Issues

The Company has not raised any money/funds from public issues, right issues, preferential allotment or qualified institutional placements as specified under Regulation 32(7a) of the SEBI Listing Regulations during the financial year 2020-21.

13.21 Right Issue

The Board of Directors in their meeting dated December 28, 2019 have approved the further issue of Equity shares to the existing shareholders of the Company on Right basis upto Rs.50 crores. Further the Board has approved the Draft Letter of offer for the Proposed Rights Issue pursuant to the provisions of SEBI (Issue of Capital and Disclosure Requirements) Regulations, 2018, as amended from time to time in its Board Meeting dated June 09, 2021. The Company is gearing up the process for equity infusion through right issue.

B. NON-MANDATORY REQUIREMENTS**Adoption of Non- mandatory Requirements**

In adherence with Regulation 27 (1) of Listing Regulations, the Company has voluntarily complied with following non-mandatory requirements:

Shareholders' Rights: The quarterly and year to date financial results/statements are published in newspapers and posted on Company's website i.e. www.shivamautotech.com.

Modified Opinion(s) in Audit Report: The Company continues to adopt best practices to ensure regime of Unmodified Opinion.

Reporting of Internal Auditor: The Internal Auditors have direct access to the Audit Committee and the Internal Auditors' presents their Audit Observations to the Audit Committee of Board.

The Board: The Chairman of the Company is a non-Executive Director.

Sd/-

For and on behalf of the Board
Neeraj Munjal
Managing Director
DIN: 00037792

Sd/-

For and on behalf of the Board
Charu Munjal
Whole Time Director
DIN: 03094545

Place: Gurugram
Date: August 13, 2021

CEO & CFO CERTIFICATE

We hereby certify to the Board that:

- (a) We have reviewed financial statements and the cash flow statement for the year ended 31st March, 2021, and that to the best of our knowledge and belief:
 - (i) these statements do not contain any materially untrue statement or omit any material fact or contain statements that might be misleading;
 - (ii) These statements together present a true and fair view of the Company's affairs and are in compliance with existing accounting standards, applicable laws and regulations.
- (b) There are, to the best of our knowledge and belief, no transactions entered into by the Company during the year which are fraudulent, illegal or violative of the Company's Code of Conduct.
- (c) We are responsible for establishing and maintaining Internal Controls for financial reporting and that we have evaluated the effectiveness of Internal Control Systems of the Company pertaining to financial reporting. We have disclosed to the Auditors and the Audit Committee, deficiencies in the design or operation of such Internal Controls, if any, of which we are aware and the steps we have taken or propose to take to rectify these deficiencies.
- (d) We have indicated to the Auditors and the Audit committee:
 - (i) Significant changes in Internal Control over financial reporting during the year;
 - (ii) Significant changes in accounting policies during the year and that the same have been disclosed in the notes to the financial statements; and
 - (iii) Instances of significant fraud of which we have become aware and the involvement therein, if any, of the management or an employee having a significant role in the Company's Internal Control System over financial reporting.

Place : Gurugram
Date : June 09, 2021

Sd/-
(NEERAJ MUNJAL
Managing Director
DIN: 00037792

Sd/-
(DAVENDRA UJLAYAN)
VP – Finance
PAN: AAFPU2249C

CERTIFICATE OF COMPLIANCE OF CODE OF CONDUCT

I, **Neeraj Munjal**, Managing Director of the Company hereby certify that the Board of Directors and the Senior Management Personnel have affirmed compliance with the Code of Conduct of the Company for the Financial Year 2020-21.

Sd/-
(NEERAJ MUNJAL)
MANAGING DIRECTOR
DIN: 00037792

Place: Gurugram
Date : June 09, 2021

CERTIFICATE OF CORPORATE GOVERNANCE

**To,
The Members of
Shivam Autotech Limited.**

We have examined the compliance of conditions of Corporate Governance by Shivam Autotech Limited (the Company) for the financial year ended 31st March 2021, as per the Regulation 17 to 27, clauses (b) to (i) of Regulation 46(2) and paragraphs C, D and E of Schedule V of the Securities and Exchange Board of India (Listing Obligations and Disclosure Requirements) Regulations, 2015 ('Listing Regulations'). The compliance of conditions of Corporate Governance is the responsibility of the Management. Our examination was limited to the procedures and implementation thereof, adopted by the Company for ensuring the compliance of the conditions of Corporate Governance. It is neither an audit nor an expression of opinion on the financial statement of the company.

In our opinion and to the best of our information and according to our examination of the relevant records and the explanations given to us and the representations made by the Officers and the management, we certify that the Company has complied with the conditions of Corporate Governance as stipulated in the above mentioned Listing Regulations, as applicable during the Financial Year ended 31st March, 2021

We further state that such compliance is neither an assurance as to the future viability of the Company nor the efficiency or effectiveness with which the Management has conducted the affairs of the Company.

Limitations

The prevailing lockdown on account of COVID-19 situation has impacted the physical verification of the documents and records as being maintained by the Company at their offices and we are constrained to determine the quantum of said impact. We have taken all possible steps to verify the records as made available to us by the Company through electronic medium and taken necessary confirmation/representation from the officials of Company, wherever required.

**Place: Gurugram
Date : 13.08.2021**

**For SATYENDER KUMAR & ASSOCIATES
Company Secretaries
Sd/-
Satyender Kumar
(Proprietor)
C.P. No. 5189
FCS 4087
UDIN: F004087C000784515**

CONSERVATION OF ENERGY, TECHNOLOGY ABSORPTION, FOREIGN EXCHANGE EARNINGS AND OUTGO

Information regarding Conservation of Energy, Technology Absorption and Foreign Exchange Earnings and Outgo pursuant to Section 134(3)(m) of the Companies Act, 2013, read with Companies (Accounts) Rules, 2014 and forming part of Board's Report

A) CONSERVATION OF ENERGY:

I. Steps taken or impact on conservation of energy:

Energy conservation initiatives, energy efficient technologies have been on the top focus in Shivam's operations. The Company believes that actions around energy bring direct benefit to bottom-line and to the climate. The Company is making continuous efforts on ongoing basis by adopting innovative measures to reduce wastage and optimise consumption. Some of key energy initiatives undertaken during the year are as under:

Energy Projects & activities taken up:

- Green Infrastructure
- Use of Timers to stop m/c /Hydraulic Power Pack during idle hours
- Energy Efficient LED Light deployment/replacement activities continues across all plants to reduce fixed consumption
- Induction Heater Auto Run to start with Press cycle
- Auto Air Blast in CNC Turning Centre
- Forward planning for optimized usage of energy sources (Direct & Indirect) to control cost
- Strengthened up training to identify the energy efficiency improvement projects.
- Focused Energy review meetings by Management
- Interplant Energy efficiency comparison and review by all the plants
- Alternate method for curing being looked into to reduce the water consumption
- Plugging Air Leakages at Regular Intervals
- Use of coil cooler in DG Set
- LPG type evaporator replaced by heater
- Chillers/AC/Panel AC temperature setting to be done at bare minimum required temperature.
- Provision of Energy Efficient Pumps for ETP/STP, Water Supply and Fire Systems
- Usage of recycle waste
- Onsite waste water treatment and its usage.
- Rain water harvesting

II. Steps taken by the Company for utilizing alternate sources of energy

The Company has installed Roof Top Solar Power Systems at Binola and Rohtak plants as an alternate source of energy, which has resulted in reducing electricity bills.

The Company is following up the concept of Green Factory Building for its Rohtak and Kolar Plant and has successfully achieved the Green Building Standards for Gold Level of Certification under the Indian Green Building Council (IGBC) Green Factory Buildings Rating System in April 2021 and June 2021 respectively and is valid for 3 years. Various initiatives have been undertaken by the Company to use waste water, to recycle waste of steel scrap, wood scrap and others.

B) TECHNOLOGY ABSORPTION

Efforts made towards Technology Absorption

Technology leadership is at the core of all Research & Development activities of the Company. Your company values Technology as a key pillar to support business growth and believes that leadership in technology only can sustain business leadership.

The Company is conscious of implementation of latest technologies in key working areas. Technology is ever-changing and employees of the Company are made aware of the latest working techniques and technologies through workshops, group e-mails, and discussion sessions for optimum utilization of available resources and to improve operational efficiency.

Successful migration from BS-IV to BS-VI technology through in-house R&D efforts across entire range of models as a part of mandatory regulatory requirement of new emission standards before March 31, 2020.

The Company is involved in supporting the MAKE IN INDIA initiative of Prime Minister by indigenizing various components as an import substitute in order to fulfill the continuous demand of the customers for price reduction. The Company continues to use the latest technologies for improving the productivity and quality of its services and products. Development and improvement of products has been an inbuilt and ongoing activity within the existing manufacturing facilities. These activities also enabled the Company to reduce process waste, lower the energy consumption and increase productivity. R&D activities of the Company helped in development of novel materials & technologies resulting into enhanced product quality and to improve process capabilities.

The Company is a pioneer of the net shape and near net shape technology, along with use of warm forging technology, especially in gear manufacturing. The Company has a suite of software for 3D & 3D CAD modelling, forging process simulation, machining process simulation, and gear design, which helps in optimized product and process design. This is further complemented by regular process innovations, and automation technologies employed for continuous improvement in the overall productivity, such as SCADA system for control and monitoring of heat treatment process furnaces. The Company has some of the most technologically advanced machines for high speed cold and hot forging, capable of producing more than 120 parts per minute, with precision and accuracy as per customer requirements. Moreover, the Company regularly works several specialized technology companies, for design and development of technologically complex components, sub-systems or systems. This has allowed the Company to file several process and product design patents, both in India & abroad.

Research & Development were carried in product development, process development, energy conservation, environment protection, cost reduction and automation. In this process design and material database are continuously improved and enhanced. Apart from process improvements, the research and development also aims at finding equivalent substitutes of various inputs and materials to have cost savings without compromising quality.

The expenditure incurred on research, development and improvement of products is an indirect cost which is reflected in the financials of the company.

Specific areas in which R & D carried out by the Company

The Company is mainly focused on specific areas of R&D and Engineering by which it can meet its Mission & Vision.

The focus of the company with respect to R&D is two-fold, i.e. to diversify product portfolio, and develop proprietary systems. The company has a dedicated R&D team, primarily working on 2 verticals, i.e. braking system and transmission system for electric vehicles. All on-going in-house R&D projects are expected to be ready for production in 2022. The product and vehicle category application mix is as per below table –

Product	Vehicle Application Category
Integrated Differential Axle – 33" / 35"	Electric Rickshaw / E-Cart
Integrated Differential Axle – 46"	L5 3W EV
EV Gearbox	2W EV Scooter + L5 3W EV + 4W EV LCV
Mechanical CBS	2W EV (Drum – Drum System)
Hydraulic CBS	2W EV (Disc – Disc System)
Split Service Braking System	L5 3W EV
Independent service braking system	Quadricycle + L2 3W EV (Export)
Tractor Front Axle	18 – 30 HP 4WD Tractor

Moreover, the company is keen to engage with EV start-ups, and provide required support for product development and series production.

c) Foreign Exchange Earnings/ Outgo:	(Rupees In Lacs)
Earnings	1769.62
Outgo	865.26

FORM No. MR-3

SECRETARIAL AUDIT REPORT

For The Financial Year ended on 31st March, 2021

(Pursuant to Section 204(1) of the Companies Act, 2013 and Rule No. 9 of the Companies (Appointment and Remuneration of Managerial Personnel) Rules, 2014)

To,

The Members,

Shivam Autotech Limited

CIN: L34300HR2005PLC081531

10, 1st Floor, Tower A, Emaar Digital Greens,

Sector – 61, Golf Course Extension Road,

Gurugram, Haryana – 122102

We have conducted the secretarial audit of the compliance of applicable statutory provisions and the adherence to good corporate practices by **Shivam Autotech Limited** (hereinafter called the Company). Secretarial Audit was conducted in a manner that provided us a reasonable basis for evaluating the corporate conducts/statutory compliances and expressing our opinion thereon.

Based on our verification of the Company's books, papers, minute books, forms and returns filed and other records maintained by the company and also the information provided by the Company, its officers, agents and authorized representatives during the conduct of secretarial audit, We hereby report that in our opinion, the company has, during the audit period covering financial year ended on 31st March, 2021 ("Audit Period") complied with the statutory provisions listed hereunder and also that the Company has proper Board-processes and compliance-mechanism in place to the extent, in the manner and subject to the reporting made hereinafter:

We have examined the books, papers, minute books, forms and returns filed and other records maintained by the Company for the financial year ended on 31st March, 2021 according to the provisions of:

- (i) The Companies Act, 2013 (the Act) and the rules made thereunder;
- (ii) The Securities Contracts (Regulation) Act, 1956 ('SCRA') and the rules made thereunder;
- (iii) The Depositories Act, 1996 and the Regulations and Bye-laws framed thereunder;
- (iv) Foreign Exchange Management Act, 1999 and the rules and regulations made thereunder to the extent of Foreign Direct Investment, Overseas Direct Investment and External Commercial Borrowings; (Not applicable to the Company during the audit period)
- (v) The following Regulations and Guidelines prescribed under the Securities and Exchange Board of India Act, 1992 ('SEBI Act'):-
 - (a) The Securities and Exchange Board of India (Substantial Acquisition of Shares and Takeovers) Regulations, 2011;
 - (b) The Securities and Exchange Board of India (Prohibition of Insider Trading) Regulations, 2015;
 - (c) Securities and Exchange Board of India (Issue of Capital and Disclosure Requirements) Regulations, 2018; (compliance yet to be initiated for rights issue during the period under review)
 - (d) The Securities and Exchange Board of India (Share Based Employee Benefits) Regulations, 2014; (Not applicable to the Company during the audit period)
 - (e) The Securities and Exchange Board of India (Issue and Listing of Debt Securities) Regulations, 2008; (Not applicable to the Company during audit the period)
 - (f) The Securities and Exchange Board of India (Registrars to an Issue and Share Transfer Agents) Regulations, 1993 regarding the Companies Act and dealing with client to the extent of securities issued; (Not applicable as the Company is not registered as Registrar to an Issue and Share Transfer Agent)

- (g) The Securities and Exchange Board of India (Delisting of Equity Shares) Regulations, 2009; and (Not applicable to the Company during the audit period)
- (h) The Securities and Exchange Board of India (Buyback of Securities) Regulations, 2018. (Not applicable to the Company during the audit period)
- vi) As confirmed and certified by the management, there is no Sectoral law specifically applicable to the Company based on the Sectors /Businesses.

We have also examined compliance with the applicable clauses/regulations of the following:

- (i) Secretarial Standards with regard to Meeting of Board of Directors (SS-1) and General Meetings (SS-2) issued by The Institute of Company Secretaries of India;
- (ii) The Securities and Exchange Board of India (Listing Obligations and Disclosure Requirements), Regulations, 2015 and Listing agreements entered into by the Company with National Stock Exchange of India Limited and BSE Limited;

During the period under review the Company has complied with the provisions of the Act, Rules, Regulations, Guidelines, Standards, etc. mentioned above except that the company has obtained loan from holding company (74.8% shares) with an option of conversion of such loan into shares, without the prior approval of members as required under Section 62(3) of the Act.

We further report that,

The Board of Directors of the Company is duly constituted with proper balance of Executive Directors, Non-Executive Directors, Independent Directors and Woman Directors. The changes in the composition of the Board of Directors that took place during the period under review were carried out in compliance with the provisions of the Act.

Adequate notice is given to all directors to schedule the Board Meetings, agenda and detailed notes on agenda were sent at least seven days in advance, and a system exists for seeking and obtaining further information and clarifications on the agenda items before the meeting and for meaningful participation at the meeting.

Majority decision is carried through while the dissenting members' views are captured and recorded as part of the minutes (during the year under review there were no instance recorded in the minutes where any director has dissented to any particular resolution).

We further report that based on review of compliance mechanism established by the Company and on the basis of the Compliance Certificate(s) issued by the KMPs and taken on record by the Board of Directors at their meeting(s), we are of the opinion that management has adequate systems and processes commensurate with the size and operations of the company to monitor and ensure compliance with applicable laws, rules, regulations and guidelines.

Limitations

The prevailing lockdown on account of COVID-19 situation has impacted the physical verification of the documents and records as being maintained by the Company at their offices and we are constrained to determine the quantum of said impact. We have taken all possible steps to verify the records as made available to us by the Company through electronic medium and taken necessary confirmation/representation from the officials of Company, wherever required.

For **SATYENDER KUMAR & ASSOCIATES**
Company Secretaries

Place: Gurugram
Date : 13.08.2021

Sd/-
Satyender Kumar
(Proprietor)
C.P. No. 5189
FCS 4087
UDIN: F004087C000784526

Note: This report is to be read with our letter of even date which is annexed as Annexure- 1 and forms an integral part of this report.

Annexure - 1

To,

The Members,

Shivam Autotech Limited

CIN: L34300HR2005PLC081531

10, 1st Floor, Tower A, Emaar Digital Greens,

Sector – 61, Golf Course Extension Road,

Gurugram, Haryana – 122102

Our report of even date is to be read along with this letter.

1. Maintenance of secretarial record is the responsibility of the management of the company. Our responsibility is to express an opinion on these secretarial records based on our audit.
2. We have followed the audit practices and processes as were appropriate to obtain reasonable assurance about the correctness of the contents of the Secretarial records. The verification was done on remote test basis to ensure that correct facts are reflected in secretarial records. We believe that the processes and practices we followed provide a reasonable basis for our opinion.
3. We have not verified the correctness and appropriateness of financial records and Books of Accounts of the company.
4. Where ever required, we have obtained the Management representation about the compliance of laws, rules and regulations and happening of events etc.
5. The compliance of the provisions of Corporate and other applicable laws, rules, regulations, standards is the responsibility of management and we have relied on the Compliance Certificates issued by KMPs.
6. The Secretarial Audit report is neither an assurance as to the future viability of the company nor of the efficacy or effectiveness with which the management has conducted the affairs of the company.

For **SATYENDER KUMAR & ASSOCIATES**
Company Secretaries

Place: Gurugram

Date : 13.08.2021

Sd/-
Satyender Kumar
(Proprietor)
C.P. No. 5189
FCS 4087
UDIN: F004087C000784526

Annexure - E**I. Information as per Section 197 of the Companies Act, 2013 read with Rule 5 (1) of Companies (Appointment and Remuneration of Managerial Personnel) Rules, 2014 and forming part of the Board's Report for the year ended March 31, 2021.****a. The ratio of the remuneration of each director to the median remuneration of the employees of the Company for the financial year 2020-21:**

Executive Directors	Ratio
Mr. Neeraj Munjal	40.43
Mrs. Charu Munjal	18.50

The Company pays only sitting fees and commission to Non-Executive Directors.

b. The percentage increase/decrease in remuneration of each Director, Chief Executive Officer, Chief Financial Officer, Company Secretary in the financial year 2020-21:

Directors, Chief Executive Officer, Chief Financial Officer and Company Secretary	% increase/decrease
Mr. Neeraj Munjal	0.00%
Mrs. Charu Munjal	0.00%
Mr. Davendra Ujlayan*	-1.63%
Ms. Samta Bajaj	8.53%

c. The percentage increase in the median remuneration of employees in the financial year 2020-21: 3.81%**d. The number of permanent employees on the rolls of Company as on March 31, 2021: 879****e. Average percentile increase/decrease already made in the salaries of employees other than the managerial personnel in the last financial year and its comparison with the percentile increase/decrease in the managerial remuneration and justification thereof and point out if there are any exceptional circumstances for increase in the managerial remuneration:**

The average percentile increase in the salaries of employees was around 2-3% after accounting for promotions and other event based compensation revisions and there is no increase in the managerial remuneration for the year.

The Company gives general increase to all its permanent workers after every three years as per the practice followed by the Company after making wage agreements with its union for three years. Apart from this, the Company gives 3 to 5 percent every year on the basis of the individual employee's performance.

Due to COVID 19 pandemic and slowdown in Auto Sector, the company has not increased the remuneration of permanent employees of the company including Managing Directors. Once the situation will be normalized the company will be able to increase the salary/remuneration of employees as per its Policy on the basis of the individual employee's performance.

f. Affirmation that the remuneration is as per the remuneration policy of the Company:

It is hereby affirmed that the remuneration paid is as per the Remuneration Policy for Directors, Key Managerial Personnel and other Employees.

II. The Statement containing particulars of employees as required under Section 197(12) of the Companies Act, 2013 read with Rule 5(2) & 5(3) of the Companies (Appointment and Remuneration of Managerial Personnel) Rules, 2014, is as mentioned below:**a. Details of the Employees, who were in receipt of remuneration aggregating Rs. 1,02,00,000 or more per annum.**

S. No	Name	Designation	Nature of employment	Remuneration (Rs. in Lacs)	Qualification & Experience (Yrs)	Age (Yrs)	Date of Commencement of Employment	Previous Employment & Designation	Shareholding
1.	Mr. Neeraj Munjal	Managing Director	Director	187.58	B.Com & DIBM 32 years	54	01.04.2006	Munjal Auto Industries Ltd. Executive Director	Nil

Notes:

1. Remuneration includes Basic Salary, Commission, other allowances and taxable value of perquisites and Company's contribution to provident fund.
2. The above mentioned appointment is on contractual basis.

b. Details of top ten employee except Managing Director

S. No	Name	Designation	Remuneration Received	Nature of employment (whether contractual or otherwise)	Qualification	Experience (in years)	Date of Commencement of employment	Age (In years)	Previous employment held by the employee before joining the company	Equity Shares of the Company held by the Employee	whether employee is relative of any director or manager, if yes, name such director or manager
1	CHARU MUNJAL	Executive Director	85,81,536	Permanent	Diploma in Textile Management	21 yrs	28/5/2013	49	N.A.	NIL	Yes, Spouse of Mr. Neeraj Munjal, Managing Director
2	DAVENDRA UJLAYAN	Vice President	68,59,800	Permanent	CS, DIRM, FCA, FII	32 yrs	12/3/2007	58	BOYSEN INDIA LTD	10	No
3	SURESH KUMAR	General Manager	44,09,136	Permanent	BE-Mechinical & Diploma	27 yrs	25/8/2010	48	SATA VIKASH INDIA PVT. LTD.	NIL	No
4	RAJESH KUMAR SRIVASTAVA	General Manager	42,08,501	Permanent	Diploma in Electrical Engineering	35 yrs	2/4/2007	54	RANAQU AUTOMOTIVE COMPONENTS LIMITED	NIL	No
5	SANJEEV GOEL	Dy. General Manager	36,42,792	Permanent	B.Tech-Mechinical & Diploma	35 yrs	1/3/2000	52	AMTEK AUTO LTD.	NIL	No
6	VIVEK SHARMA	General Manager	34,72,632	Permanent	BE-Mechinical	24 yrs	1/3/2013	48	PUNJ LLOYD LIMITED.	NIL	No
7	MANOJ KUMAR AGARWAL	Dy. General Manager	33,50,928	Permanent	B.Tech-Mechinical & Diploma	33 yrs	15/12/1999	54	BENDA AMTEK LTD.	NIL	No
8	ANSHUMAN SHARMA	Dy. General Manager	29,05,416	Permanent	PGD-PMIR, Master of Labour mgt	23 Yrs	22/7/2013	45	ASAHI INDIA GLASS LTD.	NIL	No
9	SUBHASH SINGH NEGI	Asst. General Manager	27,21,792	Permanent	PGDM-Operations, Diploma in Mechanical	27 yrs	13/3/2018	51	KAFILA FORGE LIMITED	NIL	No
10	KAMAL SHARMA	Asst. General Manager	26,80,116	Permanent	Diploma-Mechanical	32 yrs	7/2/2000	53	ESCORTS LTD	NIL	No

CERTIFICATE OF NON-DISQUALIFICATION OF DIRECTORS

(pursuant to Regulation 34(3) and Schedule V Para C clause (10)(i) of the SEBI (Listing Obligations and Disclosure Requirements) Regulations, 2015)

To,

The Members of
Shivam Autotech Limited
CIN: L34300HR2005PLC081531
10, 1st Floor, Tower A, Emaar Digital Greens,
Sector 61, Golf Course Extension Road,
Gurugram, Haryana-122102

We have examined the following documents:

- i) Declaration of non-disqualification as required under Section 164 of Companies Act, 2013 ('the Act');
- ii) Disclosure of concern or interests as required under Section 184 of the Act;

(hereinafter referred to as 'relevant documents')

as submitted by the Directors of Shivam Autotech Limited ('the Company') bearing CIN: L34300HR2005PLC081531 and having its registered office at 10, 1st Floor, Tower A, Emaar Digital Greens, Sector 61, Golf Course Extension Road, Gurugram, Haryana-122102 to the Board of Directors of the Company ('the Board') for the Financial Year ended 31st March, 2021 and relevant registers, records, forms and returns maintained by the Company and as made available to us for the purpose of issuing this Certificate in accordance with Regulation 34(3) read with Schedule V Para C Clause 10(i) of SEBI (Listing Obligations and Disclosure Requirements) Regulations, 2015.

We have considered non-disqualification to include non-debarment by Regulatory/ Statutory Authorities. It is the responsibility of Directors to submit relevant documents with complete and accurate information in accordance with the provisions of the Act.

Ensuring the eligibility for the appointment / continuity of every Director on the Board is the responsibility of the management of the Company. Our responsibility is to express an opinion on the basis of our verification.

Based on our examination as aforesaid and such other verifications carried out by us as deemed necessary and adequate (including Directors Identification Number (DIN) status at the portal www.mca.gov.in), in our opinion and to the best of our information and knowledge and according to the explanations provided by the Company, its officers and authorized representatives, we hereby certify that none of the Directors on the Board of the Company, as listed hereunder for the Financial Year ending 31st March, 2021, have been debarred or disqualified from being appointed or continuing as Directors of Companies by Securities and Exchange Board of India/Ministry of Corporate Affairs or any such statutory authority.

Sr. No.	Name of Director	DIN	Date of appointment in Company
1.	Mr. Neeraj Munjal	00037792	29/07/2005
2.	Mr. Bhagwan Das Narang	00826573	14/02/2006
3.	Dr. Anil Kumar Gupta	02643623	09/08/2019
4.	Mrs. Charu Munjal	03094545	28/05/2013
5.	Ms. Jyothi Prasad	06947488	13/11/2019
6.	Mr. Sunil Chinubhai Vakil	02527630	21/12/2020

Note: Mr. Sunil Kant Munjal (DIN:00003902) has resigned as an Independent Director of the Company w.e.f. 24.09.2020.

This certificate is neither an assurance as to the future viability of the Company nor of the efficiency or effectiveness with which the management has conducted the affairs of the Company.

This Certificate has been issued at the request of the Company to make disclosure in its Corporate Governance Report of the Financial Year ended 31st March, 2021.

For **SATYENDER KUMAR & ASSOCIATES**
Company Secretaries

Sd/-
Satyender Kumar
(Proprietor)

C.P. No. 5189

UDIN: F004087C000784504

Place: Gurugram

Date : 13.8.2021

ANNUAL REPORT ON CORPORATE SOCIAL RESPONSIBILITY (CSR) ACTIVITIES

1. Brief outline on CSR Policy of the Company.

At Shivam Autotech Limited, Corporate Social Responsibility (CSR) has played a pivotal role in improving the lives of communities and society at large, and in and around our operations, with an objective to energize, involve and enable them to realize their potential. This has also enabled us to fulfil our commitment to be a socially responsible corporate citizen.

Objective of CSR policy

The main objective of Shivam's CSR policy is -

- To lay down guidelines to make CSR a key business process for sustainable development for the society.
- To take projects/ initiatives resulting in enhancement in the quality of life and economic well-being of the community, in and around society at large.

The Company had contributed towards CSR activities, by providing financial aid to some foundations, trusts etc. involved in the field of promoting education, healthcare, eradicating hunger and sanitation, especially for the benefit of differently abled person. The above areas are mapped with the activities as prescribed in Schedule VII to the Companies Act, 2013.

The Company implement the CSR Programmes through Company personnel or through external implementing agencies and ensure proper governance, monitoring and reporting thereof.

Our aim is to be one of the most respected companies in India delivering superior and sustainable value to all our customers, business partners, shareholders, employees and host communities. The CSR initiatives focus on holistic development of host communities and create social, environmental and economic value to the society.

To pursue these objectives, we will continue to:

- a. Uphold and promote the principles of inclusive growth and equitable development.
- b. Develop Community Development Plans based on needs and priorities of host communities and measure the effectiveness of community development programmes.
- c. Work actively in areas of preventive health and sanitation, education, skills for employability, livelihoods and income generation, waste resource management and water conservation for host communities for enhancing Human Development Index.
- d. Collaborate with likeminded bodies like governments, voluntary organizations and academic institutes in pursuit of our goals.
- e. Interact regularly with stakeholders, review and publicly report our CSR initiatives.

2. Composition of CSR Committee (Dissolved w.e.f. February 12, 2021)

Sl. No.	Name of Director	Designation/Nature of Directorship	Number of meetings of CSR Committee held during the year	Number of meetings of CSR Committee attended during the year
1.	Dr. Anil Kumar Gupta	Chairman of the Committee- Non-Executive Director	1	1
2.	Mr. Bhagwan Dass Narang	Member- Non-Executive and Independent Director	1	1
3.	Mrs. Charu Munjal	Member- Executive (Whole-Time) Director	1	1

(c) Details of CSR amount spent against other than ongoing project for the financial year:

1.	2.	3.	4.	5.		6.	7.	8.	
				State	District			Name	CSR Registration number (Applicable w.e.f. April 01, 2021)
S. No.	Name of the Project	Items from the list of activities in Schedule VII to the Act	Local area (Yes/No)	Location of the Project		Amount spent for the project (in Rs.)	Mode of implementation Direct (Yes/No)	Mode of implementation Through Implementing Agency	
1.	Paid to Disha Charitable Trust, a Referral, Information and Guidance Centre for persons with disabilities.	ii. promoting education, including special education and employment enhancing vocation skills especially among children, women, elderly and the differently abled and livelihood enhancement projects.	No	Gujarat	Vadodra	2,00,000/-	Yes	-	Not Applicable
TOTAL						2,00,000/-			

(d) Amount spent in Administrative Overheads: NIL**(e) Amount spent on Impact Assessment, if applicable:** Not Applicable**(f) Total amount spent for the financial Year (8b + 8c + 8d + 8e):** Rs. 2,00,000**(g) Excess amount for set off, if any:**

Sl. No.	Particular	Amount (in Rs. Lakhs)
(i)	Two percent of average net profit of the Company as per section 135(5)	(46.10)
(ii)	Total amount spent for the financial year	2.00
(iii)	Excess amount spent for the financial year [(ii)-(i)]	2.00
(iv)	Surplus arising out of the CSR projects or programmes or activities of the previous financial years, if any	NIL
(v)	Amount available for set off in succeeding financial years [(iii)-(iv)]	2.00

9. (a) Details of Unspent CSR amount for the preceding three financial years:

Sl. No.	Preceding Financial Year	Amount transferred to Unspent CSR Account under Section 135 (6) (in Rs.)	Amount spent in the reporting Financial Year (in Rs.)	Amount transferred to any fund specified under Schedule VII as per section 135 (6), if any.			Amount remaining to be spent in succeeding financial years. (in Rs.)
				Name of the Fund	Amount (in Rs.)	Date of transfer	
1.	2018-19 Rs. 3.42 lakhs was unspent due to non-identification of appropriate projects / activities / programmes in line with the CSR policy of the Company	NA	NA	NA	NA	NA	NA

(b) Details of CSR amount spent in the financial year for ongoing projects of the preceding financial year(s):

(1)	(2)	(3)	(4)	(5)	(6)	(7)	(8)	(9)
Sl. No.	Project ID	Name of the project	Financial year in which the project was commenced	Project duration	Total amount allocated for the project (in Rs.)	Amount Spent on the project in reporting Financial year (in Rs.)	Cumulative amount Spent at the end of reporting Financial year (in Rs.)	Status of the project- Completed/ Ongoing
NIL								

11. In case of creation or acquisition of capital asset, furnish the details relating to the asset so created or acquired through CSR spent in the financial year:

Not applicable

12. Specify the reason(s), if the company has failed to spend the two per cent of the average net profit as per section 135(5):

Not Applicable

Place: Gurugram
Date: August 13, 2021

Sd/-
Neeraj Munjal
Managing Director
DIN: 00037792

Sd/-
Anil Kumar Gupta
Chairman, CSR Committee
DIN: 02643623

INDEPENDENT

AUDITORS'
REPORT**To the Members of Shivam Autotech Limited****Report on the Audit of the Financial Statements****Opinion**

We have audited the accompanying financial statements of **Shivam Autotech Limited** ("the Company"), which comprise the Balance Sheet as at March 31, 2021, the Statement of Profit and Loss (including Other Comprehensive Income), the Statement of Changes in Equity and the Statement of Cash Flows for the year ended on that date, and notes to the financial statements including a summary of the significant accounting policies and other explanatory information (hereinafter referred to as "the financial statements").

In our opinion and to the best of our information and according to the explanations given to us, the aforesaid financial statements give the information required by the Companies Act, 2013 ("the Act") in the manner so required and give a true and fair view in conformity with the Indian Accounting Standards prescribed under section 133 of the Act read with the Companies (Indian Accounting Standards) Rules, 2015, as amended, thereof ("Ind AS") and other accounting principles generally accepted in India, of the state of affairs of the Company as at March 31, 2021, the loss and total comprehensive losses, changes in equity and its cash flows for the year ended on that date.

Basis for Opinion

We conducted our audit of the financial statements in accordance with the Standards on Auditing specified under section 143(10) of the Act (SAs). Our responsibilities under those Standards are further described in the Auditor's Responsibilities for the Audit of the financial statements section of our report. We are independent of the Company in accordance with the Code of Ethics issued by the Institute of Chartered Accountants of India (ICAI) together with the ethical requirements that are relevant to our audit of the financial statements under the provisions of the Act and the Rules made thereunder, and we have fulfilled our other ethical responsibilities in accordance with these requirements and the ICAI's Code of Ethics.

We believe that the audit evidence obtained by us is sufficient and appropriate to provide a basis for our audit opinion on the financial statements.

Emphasis of Matter

We draw attention to:

- i. Note 7 in the financial statements, wherein management has recognized deferred tax assets on the assumption that there would be sufficient future taxable profits, more fully been explained in the said note for reversal of such deferred tax assets.
- ii. Note 10 in the financial statements, regarding the booking of material consumption and accounting impact of physical verification observations, more fully been explained in the said note.

Our opinion is not modified in respect of above matters.

Key Audit Matters

Key audit matters (KAM) are those matters that, in our professional judgment were of most significance in our audit of the financial statements of the current period. These matters were addressed in the context of our audit of the financial statements as a whole, and in forming our opinion thereon, and we do not provide a separate opinion on these matters.

We have determined that there are no key audit matters to communicate in our report.

Information Other than the Financial Statements and Auditor's Report Thereon

The Company's Board of Directors is responsible for the other information. The other information comprises the information included in the Management Discussion and Analysis, Board's Report including Annexures to Board's Report, Business Responsibility Report, Corporate Governance and Shareholder's Information, but does not include the standalone financial statements and our auditor's report thereon. The Annual Report is expected to be made available to us after the date of this Auditors' Report. Our opinion on the standalone financial statements does not cover the other information and we do not express any form of assurance conclusion thereon.

In connection with our audit of the standalone financial statements, our responsibility is to read the other information and, in doing so, consider whether the other information is materially inconsistent with the standalone financial statements or our knowledge obtained during the course of our audit or otherwise appears to be materially misstated.

If, based on the work we have performed, we conclude that there is a material misstatement of this other information, we are required to report that fact. We have nothing to report in this regard.

Management's Responsibilities for the Financial Statements

The Company's Board of Directors is responsible for the matters stated in Section 134(5) of the Act with respect to the preparation of these financial statements that give a true and fair view of the financial position, financial performance, total comprehensive losses, changes in equity and cash flows of the Company in accordance with accounting principles generally accepted in India, including the Indian Accounting Standard (Ind AS) specified under Section 133 of the Act, read with the Companies (Indian Accounting Standards) Rules, 2015, as amended, thereof.

This responsibility also includes maintenance of adequate accounting records in accordance with the provisions of the Act for safeguarding the assets of the Company and for preventing and detecting frauds and other irregularities; selection and application of appropriate accounting policies; making judgments and estimates that are reasonable and prudent; and design, implementation and maintenance of adequate internal financial controls, that were operating effectively for ensuring the accuracy and completeness of the accounting records, relevant to the preparation and presentation of the financial statements that give a true and fair view and are free from material misstatement, whether due to fraud or error.

In preparing the financial statements, management is responsible for assessing the Company's ability to continue as a going concern, disclosing, as applicable, matters related to going concern and using the going concern basis of accounting unless management either intends to liquidate the Company or to cease operations, or has no realistic alternative but to do so.

The Board of Directors are responsible for overseeing the Company's financial reporting process.

Auditor's Responsibilities for the Audit of the Financial Statements

Our objectives are to obtain reasonable assurance about whether the financial statements as a whole are free from material misstatement, whether due to fraud or error, and to issue an auditor's report that includes our opinion. Reasonable assurance is a high level of assurance, but is not a guarantee that an audit conducted in accordance with SAs will always detect a material misstatement when it exists. Misstatements can arise from fraud or error and are considered material if, individually or in the aggregate, they could reasonably be expected to influence the economic decisions of users taken on the basis of these financial statements.

As part of an audit in accordance with SAs, we exercise professional judgment and maintain professional skepticism throughout the audit. We also:

- Identify and assess the risks of material misstatement of the financial statements, whether due to fraud or error, design and perform audit procedures responsive to those risks, and obtain audit evidence that is sufficient and appropriate to provide a basis for our opinion. The risk of not detecting a material misstatement resulting from fraud is higher than for one resulting from error, as fraud may involve collusion, forgery, intentional omissions, misrepresentations, or the override of internal control.
- Obtain an understanding of internal financial control relevant to the audit in order to design audit procedures that are appropriate in the circumstances. Under section 143(3) (i) of the Act, we are also responsible for expressing our opinion on whether the Company has adequate internal financial controls system in place and the operating effectiveness of such controls.
- Evaluate the appropriateness of accounting policies used and the reasonableness of accounting estimates and related disclosures made by the management.
- Conclude on the appropriateness of management's use of the going concern basis of accounting and, based on the audit evidence obtained, whether a material uncertainty exists related to events or conditions that may cast significant doubt on the Company's ability to continue as a going concern. If we conclude that a material uncertainty exists, we are required to draw attention in our auditor's report to the related disclosures in the financial statements or, if such disclosures are inadequate, to modify our opinion. Our conclusions are based on the audit evidence obtained up to the date of our auditor's report. However, future events or conditions may cause the Company to cease to continue as a going concern.
- Evaluate the overall presentation, structure and content of the financial statements, including the disclosures, and whether the financial statements represent the underlying transactions and events in a manner that achieves fair presentation.

Materiality is the magnitude of misstatements in the financial statements that, individually or in aggregate, makes it probable that the economic decisions of a reasonably knowledgeable user of the financial statements may be influenced. We consider quantitative materiality and qualitative factors in (i) planning the scope of our audit work and in evaluating the results of our work; and (ii) to evaluate the effect of any identified misstatements in the financial statements.

We communicate with those charged with governance regarding, among other matters, the planned scope and timing of the audit and significant audit findings, including any significant deficiencies in internal control that we identify during our audit.

We also provide those charged with governance with a statement that we have complied with relevant ethical requirements regarding independence, and to communicate with them all relationships and other matters that may reasonably be thought to bear on our independence, and where applicable, related safeguards.

From the matters communicated with those charged with governance, we determine those matters that were of most significance in the audit of the financial statements of the current period and are therefore the key audit matters. We describe these matters in our auditor's report unless law or regulation precludes public disclosure about the matter or when, in extremely rare circumstances, we determine that a matter should not be communicated in our report because the adverse consequences of doing so would reasonably be expected to outweigh the public interest benefits of such communication.

Report on Other Legal and Regulatory Requirements

1. As required by the Companies (Auditor's Report) Order, 2016 ("the Order") issued by the Central Government of India in terms of Section 143(11) of the Act, we give in "Annexure A" a statement on the matters specified in paragraphs 3 and 4 of the Order.
2. As required by Section 143(3) of the Act, based on our audit we report that:

- a) We have sought and obtained all the information and explanations which to the best of our knowledge and belief were necessary for the purposes of our audit of the aforesaid financial statements;
- b) In our opinion, proper books of account as required by law have been kept by the Company so far as it appears from our examination of those books;
- c) The balance sheet, the statement of profit and loss including other comprehensive income, statement of cash flow and the statement of changes in equity dealt with by this Report are in agreement with the relevant books of account;
- d) In our opinion, the aforesaid financial statements comply with the Accounting standard specified under Section 133 of the Act, read with the Companies (Indian Accounting Standards) Rules, 2015, as amended, thereof;
- e) On the basis of the written representations received from the directors as on March 31, 2021 and taken on record by the Board of Directors, none of the directors is disqualified as on March 31, 2021 from being appointed as a director in terms of Section 164 (2) of the Act;
- f) With respect to the adequacy of the internal financial controls over financial reporting of the Company and the operating effectiveness of such controls, refer to our separate Report in "Annexure B".
- g) With respect to the other matters to be included in the Auditor's Report in accordance with the requirements of section 197(16) of the Act, as amended:

In our opinion and to the best of our information and according to the explanations given to us, the remuneration paid by the Company to its directors during the year is in accordance with the provisions of section 197 of the Act; and

- h) With respect to the other matters to be included in the Auditor's Report in accordance with Rule 11 of the Companies (Audit and Auditors) Rules, 2014, as amended in our opinion and to the best of our information and according to the explanations given to us:
 - i. The Company has disclosed the impact of pending litigations as at March 31, 2021 on its financial position in its financial statements – Refer Note 31 to the financial statements;
 - ii. The Company has made provisions, as required under the applicable law or accounting standards, for material foreseeable losses, if any, on long-term contracts including derivative contracts; and
 - iii. There has been no delay in transferring amounts required to be transferred to the Investor Education and Protection Fund by the Company during the year ended March 31, 2021.

For **NSBP & Co.**
Chartered Accountants
Firm's Registration No. 001075N

Sd/-
Deepak K. Aggarwal
Partner

Membership No: 095541
UDIN : 21095541AAAAFP5801

Place: New Delhi
Date: June 09, 2021

Annexure A to the Independent Auditor's Report to the members of Shivam Autotech Limited on its financial statements dated June 09, 2021.

Report on the matters specified in paragraph 3 of the Companies (Auditor's Report) Order, 2016 ("the Order") issued by the Central Government of India in terms of section 143(11) of the Companies Act, 2013 ("the Act") as referred to in paragraph 1 of 'Report on Other Legal and Regulatory Requirements' section

- (i) (a) The Company has maintained proper records showing full particulars including quantitative details and situation of fixed assets.
- (b) The fixed assets have been physically verified by the management according to a phased program designed to cover all the items over a period of three years, which in our opinion, is reasonable having regard to the size of the Company and the nature of its assets. However due to Covid-19 pandemic, the fixed assets have not been physically verified by the management during the year.
- (c) According to the information and explanation given to us and on the basis of our examination of the records of the Company, the title deed of immovable properties are held in the name of the company.
- (ii) The inventories of the Company except for stock lying with third parties and stock in transit, have been physically verified by the management at reasonable intervals. In our opinion and the procedures of physical verification of inventory followed by the Management are reasonable in relation to the size of the Company and nature of its business. Discrepancies noticed on such physical verification of inventory as compared to book records were material and have been properly dealt with in the books.

Further, our attendance for inventory physical verification at Haridwar plant was impracticable due to increase in Covid-19 cases and we have relied on the physical verification done by the management, also refer to our report on Internal Financial Controls in Annexure B of this report.

- (iii) The Company has not granted any loans, secured or unsecured, to companies, firms and limited liability partnership or other parties covered in the register maintained under section 189 of the Act. Accordingly, clauses 3(iii) (a) to (c) of the Order are not applicable.
- (iv) According to the information and explanations given to us, there are no loans, investments, guarantees, and securities granted in respect of which provisions of section 185 and 186 of the Act are applicable. Hence, clause 3(iv) of the Order is not applicable to the Company.
- (v) In our opinion and according to the information and explanations given to us, the Company has not accepted deposits from the public within the meaning of directives issued by the Reserve Bank of India and provisions of sections 73 to 76 or any other relevant provisions of the Act and the Rules framed thereunder.
- (vi) According to the information and explanation given to us, The Central Government has not prescribed maintenance of cost records under section 148(1) of the Act in respect of business carried out by the company. Therefore, reporting under clause 3(vi) of the order is not applicable to the Company.
- (vii) (a) According to the records of the Company examined by us and the information and explanations given to us, the Company is generally regular in depositing undisputed statutory dues including Investor Education and Protection Fund, Income Tax, Value Added Tax, Wealth Tax, Service Tax, Custom Duty, Excise duty, Cess and any other material statutory dues, as applicable, within the prescribed time with the appropriate authorities during the year, except for the payment to Employees' Provident Fund, Employees' State Insurance, Goods and Service Tax and Tax Deducted at Source and there are no such undisputed amounts payable which have remained outstanding as at March 31, 2021 for a period of more than six months from the date they became payable.
- (b) According to the information and explanations given to us and as per the books and records examined by us, there are no dues of Custom Duty, Excise Duty, Service Tax and Sales Tax/ Value Added Tax/Goods & Service Tax and Cess which have not been deposited on account of any dispute, except the following in respect of disputed value added tax along with the forum where dispute is pending:

S. No	Name of the Statute	Nature of Dues	Gross Amount Disputed (Rs. Lakhs)	Amount Deposited (Rs. Lakhs)	Period to which the amount relates	Forum where the dispute is pending
1.	Value Added Tax Act 2005	Non-submission of Form F	247.01	23.75	2014-15	Joint Commissioner, Haridwar, Uttarakhand
2.	Value Added Tax Act 2005	Non-submission of Form F	30.01	2.09	2015-16	Joint Commissioner, Haridwar, Uttarakhand
3.	Value Added Tax Act 2005	Non-submission of Form F	107.19	-	2016-17	Refer note 1 below

Note 1: As explained by the management, they are in the process of filling the appeal against the demand at appropriate forum.

- (viii) According to the information and explanations given to us and as per the books and records examined by us, The Company has not taken any loan from debenture holders, Government and financial institution. During the year, Company has availed the moratorium during COVID-19 period as announced by Reserve bank of India, delay in payment of certain principal and interest were not treated as default. However, the default in repayment of principal/interest to the banks as on the balance sheet date are as follows: -Refer note no 39 (III) of the financial statements.

Rs. in lakhs

Sr.	Name of lender	Borrowings/Principal		Interest		Remarks
		Outstanding balance as at March 31, 2021		Outstanding balance as at March 31, 2021		
		Amount	Period (In days)	Amount	Period (In days)	
1	Yes Bank - 100Cr	85.24	21	-	-	Default is subsequently made good on 19-04-2021
2	Yes Bank - 50Cr -Term Loan -2	194.00	23	-	-	Default is subsequently made good on 19-04-2021
3	Yes Bank – ECLGS	-	-	31.34	1	Default is subsequently made good on 19-04-2021
4	Yes Bank -Funded Interest Term Loan	50.18	1	0.33	1	Default is subsequently made good on 19-04-2021
5	Yes Bank -Funded Interest Term Loan	10.10	23	-	-	Default is subsequently made good on 19-04-2021
6	Yes Bank -Funded Interest Term Loan	3.85	3	-	-	Default is subsequently made good on 19-04-2021
7	RBL Bank	19.05	1	4.63	1	Default is subsequently made good on 04-04-2021

- (ix) According to the information and explanations given by the management, the Company has not raised any monies by way of initial public offer or further public offer during the financial year and the terms loans raised by the Company have been applied for the purpose for which they are obtained. Where such end use has been stipulated by the lender(s).
During the year, the Company has availed the loan under Emergency Credit Line Guarantee Scheme (“ECLGS”) scheme as per the RBI notification on Resolution Framework for COVID-19-related Stress – Financial Parameters dated September 7, 2020 aggregating of Rs 7,949.00 Lakhs out of which, Rs. 4,100.00 Lakhs has not been utilised till balance sheet date and the same has been kept in current account of the Company.
- (x) During the course of our examination of the books and records of the Company carried out in accordance with the generally accepted auditing practices in India, we have neither come across any instance of fraud on or by the Company or any fraud on the Company by its officers or employees has been noticed or reported during the year, nor have we been informed of such case by the management of the company.
- (xi) In our opinion, and according to the information and explanations given to us, the managerial remuneration has been paid / provided in accordance with the requisite approvals mandated by the provisions of section 197 read with Schedule V to the Act.
- (xii) The Company is not a Nidhi Company, hence clause (xii) of the Order is not applicable to the Company.
- (xiii) In our opinion, and according to the information and explanations given to us during the course of audit, transactions with the related parties are in compliance with section 177 and section 188 of the Act and the details have been disclosed in the notes to the financial statements, as required by the applicable accounting standards.
- (xiv) According to the information and explanations given to us and on an overall examination of the balance sheet, the Company has not made any preferential allotment or private placement of shares or fully or partly convertible debentures during the year under review and hence, reporting requirements under clause 3(xiv) are not applicable to the Company and, not commented upon.
- (xv) In our opinion and on the basis of information and explanations given to us, the Company has not entered into non-cash transactions with directors and persons connected with him. Hence, the provisions of section 192 of Act are not applicable.
- (xvi) In our opinion and on the basis of information and explanations given to us, the Company is not required to be registered under section 45-IA of the Reserve Bank of India Act, 1934.

For **NSBP & Co.**
Chartered Accountants
Firm Registration No. 001075N
Sd/-
Deepak K. Aggarwal
Partner
Membership No: 095541
UDIN:- 21095541AAAAFP5801

Place: New Delhi
Date: June 09, 2021

Annexure B to the Independent Auditor's Report to the members of Shivam Autotech Limited ('the Company') on its financial statement dated June 09, 2021.

Report on the Internal Financial Controls under Clause (i) of Sub-section 3 of Section 143 of the Companies Act, 2013 ("the Act") as referred to in paragraph 1(f) of 'Report on Other Legal and Regulatory Requirements' section

We have audited the internal financial controls over financial reporting of **Shivam Autotech Limited** ("the Company") as of March 31, 2021 in conjunction with our audit of the financial statements of the Company for the year ended on that date.

Management's Responsibility for Internal Financial Controls

The Management and Board of Directors of the Company is responsible for establishing and maintaining internal financial controls based on the internal control over financial reporting criteria established by the Company considering the essential components of internal control stated in the "Guidance Note on Audit of Internal Financial Controls Over Financial Reporting issued by the Institute of Chartered Accountants of India". These responsibilities include the design, implementation and maintenance of adequate internal financial controls that were operating effectively for ensuring the orderly and efficient conduct of its business, including adherence to the Company's policies, the safeguarding of its assets, the prevention and detection of frauds and errors, the accuracy and completeness of the accounting records, and the timely preparation of reliable financial information, as required under the Act.

Auditor's Responsibility

Our responsibility is to express an opinion on the Company's internal financial controls over financial reporting of the Company based on our audit.

We conducted our audit in accordance with the Guidance Note on Audit of Internal Financial Controls Over Financial Reporting (the "Guidance Note") and the Standards on Auditing, prescribed under section 143(10) of the Act, to the extent applicable to an audit of internal financial controls, both applicable to an audit of Internal Financial Controls and, both issued by the Institute of Chartered Accountants of India. Those Standards and the Guidance Note require that we comply with ethical requirements and plan and perform the audit to obtain reasonable assurance about whether adequate internal financial controls over financial reporting was established and maintained and if such controls operated effectively in all material respects.

Our audit involves performing procedures to obtain audit evidence about the adequacy of the internal financial controls system over financial reporting and their operating effectiveness.

Our audit of internal financial controls over financial reporting included obtaining an understanding of internal financial controls over financial reporting, assessing the risk that a material weakness exists, and testing and evaluating the design and operating effectiveness of internal control based on the assessed risk. The procedures selected depend on the auditor's judgment, including the assessment of the risks of material misstatement of the financial statements, whether due to fraud or error.

We believe that the audit evidence we have obtained is sufficient and appropriate to provide a basis for our Qualified audit opinion on the Company's internal financial controls system over financial reporting with reference to these financial statements.

Meaning of Internal Financial Controls over Financial Reporting

A Company's internal financial control over financial reporting is a process designed to provide reasonable assurance regarding the reliability of financial reporting and the preparation of financial statements for external purposes in accordance with generally accepted accounting principles. A Company's internal financial control over financial reporting includes those policies and procedures that:

- a) pertain to the maintenance of records that, in reasonable detail, accurately and fairly reflect the transactions and dispositions of the assets of the company;
- b) provide reasonable assurance that transactions are recorded as necessary to permit preparation of financial statements in accordance with generally accepted accounting principles, and that receipts and expenditures of the company are being made only in accordance with authorizations of management and directors of the company; and
- c) provide reasonable assurance regarding prevention or timely detection of unauthorized acquisition, use, or disposition of the company's assets that could have a material effect on the financial statements.

Inherent Limitations of Internal Financial Controls over Financial Reporting

Because of the inherent limitations of internal financial controls over financial reporting, including the possibility of collusion or improper management override of controls, material misstatements due to error or fraud may occur and not be detected. Also, projections of any evaluation of the internal financial controls over financial reporting to future periods are subject to the risk

that the internal financial control over financial reporting may become inadequate because of changes in conditions, or that the degree of compliance with the policies or procedures may deteriorate.

Qualified Opinion

According to the information and explanations given to us and based on our audit, the following material weakness has been identified in the operating effectiveness with reference to its financial statements as at March 31, 2021.

- i. The Company's internal control system in respect of supervisory and review controls over process of booking of material consumption, booking of proper inventory and accounting of returnable gate pass, reconciliation of old stock lying with third party and allocation of fixed and variable overheads on product costing on periodical basis were not operating effectively during the current financial year to arrive at the correct value of stock including physical number, which could potentially result in material misstatement of cost of goods sold and inventories as on March 31, 2021.

Based on physical verification of Inventories, consumption and reconciliation of closing stock as done by the Management subsequently, necessary remedial measures have been taken to arrive at the correct value of inventories as on March 31, 2021 and also to arrive at cost of goods sold for the year then ended.

- ii. The Company's internal control weakness has been observed in respect of approval of expenses/ reimbursement of expenses and payment to the vendors/employees were not operating effectively and due to deficiency in the control, the company has made some excess payment to vendors/employees of the company however as confirmed by management these payments were subsequently been approved by the management of the company.
- iii. Due to issues and bugs in software the system is not able to calculate the depreciation correctly. All variations in depreciation on account of these issues are updated in the system manually on the basis of manual depreciation calculation. The management is in continuous discussions with the software provider to fix this anomaly in the system so that correct output can be obtained directly from the system.

A 'material weakness' is a deficiency, or a combination of deficiencies, in internal financial control over financial reporting, such that there is a reasonable possibility that a material misstatement of the company's annual or interim financial statements will not be prevented or detected on a timely basis.

In our opinion, the Company has, in all material respects, maintained adequate internal financial controls over financial reporting with reference to these financial statements as of March 31, 2021, based on the internal control over financial reporting criteria established by the Company considering the essential components of internal control stated in the Guidance Note on Audit of Internal Financial Controls Over Financial Reporting issued by the Institute of Chartered Accountants of India, and except for the possible effects of the material weakness described above on the achievement of the objectives of the control criteria, the Company's internal financial controls over financial reporting with reference to these financial statements were operating effectively as of March 31, 2021.

Explanatory paragraph

We have also audited, in accordance with the Standards on Auditing issued by ICAI, as specified under Section 143(10) of the Act, the financial statements of the Company, which comprise the balance sheet as at March 31, 2021, and the statement of profit and loss, statement of changes in equity and cash flow statement for the year then ended, and a summary of significant accounting policies and other explanatory information. This material weakness was considered in determining the nature, timing, and extent of audit tests applied in our audit of the March 31, 2021 financial statements of the Company and this report does not affect our report dated June 09, 2021, which expressed an unmodified opinion on these financial statements.

For **NSBP & Co.**
Chartered Accountants
Firm Registration No. 001075N

Place: New Delhi
Date: June 09, 2021

Sd/-
Deepak K. Aggarwal
Partner
Membership No: 09554
UDIN:21095541AAAAFP5801

BALANCE SHEET AS AT MARCH 31, 2021

(All amounts are in lakhs unless otherwise stated)

	Note	As at March 31, 2021	As at March 31, 2020
A) ASSETS			
1) Non - current assets			
(a) Property, plant and equipment	4	42,203.28	43,779.43
(b) Right-of-use assets	5.1	681.89	924.52
(c) Capital work - in - progress	5.2	46.62	2,753.72
(d) Intangible assets	4	58.22	110.83
(e) Intangible assets under development	5.3	47.00	72.30
(f) Financial assets	6		
(i) Loans	6.1	629.78	650.80
(ii) Others	6.2	715.72	355.73
(g) Deferred tax assets (net)	7	3,669.31	3,335.15
(h) Income tax assets (net)	8	49.60	455.73
(i) Other non - current assets	9	474.54	108.56
		48,575.96	52,546.77
2) Current assets			
(a) Inventories	10	8,851.63	8,599.05
(b) Financial assets	11		
(i) Trade receivables	11.1	6,738.41	7,143.51
(ii) Cash and cash equivalents	11.2	5,327.34	321.36
(iii) Bank Balances other than (ii) above	11.3	868.05	414.61
(iv) Loans	11.4	16.76	37.32
(v) Others	11.5	302.28	27.26
(c) Other current assets	12	2,760.67	3,342.51
		24,865.14	19,885.62
Total Assets		73,441.10	72,432.39
B) EQUITY AND LIABILITIES			
1) EQUITY			
(a) Equity share capital	13	2,000.00	2,000.00
(b) Other equity		9,302.14	11,516.73
		11,302.14	13,516.73
2) LIABILITIES			
Non - current liabilities			
(a) Financial liabilities	14		
Borrowings	14.1	24,531.40	20,373.17
Lease Liabilities		660.80	887.19
(b) Provisions	15	687.79	662.29
(c) Other non-current liabilities	16	24.55	25.45
		25,904.54	21,948.10
Current liabilities			
(a) Financial liabilities	17		
(i) Borrowings	17.1	13,695.31	17,801.45
(ii) Trade payables	17.2		
-Dues to micro enterprises & small enterprises		1,388.21	1,367.71
-Other trade payable		6,467.38	8,811.15
(iii) Lease Liabilities		119.10	99.86
(iv) Other financial liabilities	17.3	12,270.17	7,234.20
(b) Other current liabilities	18	2,276.84	1,637.37
(c) Provisions	19	17.41	15.82
		36,234.42	36,967.56
Total Equity & Liabilities		73,441.10	72,432.39
Corporate Information	1		
Basis of preparation of financial statement	2		
Significant accounting policies	3		
The accompanying notes 1 to 48 forms an integral part of the financial statements.			

As per report of even date

For NSBP & Co.Chartered Accountants
Firm Regn. No. 001075N

Sd/-

Deepak K. Aggarwal

Partner

Membership No. 095541

Place : New Delhi

Dated : June 09, 2021

**For & on behalf of the Board of Directors of
Shivam Autotech Limited**

Sd/-

Charu Munjal

Whole Time Director

DIN: 03094545

Sd/-

Samta Bajaj

Company Secretary

M No 50269

Sd/-

Neeraj Munjal

Managing Director

DIN : 00037792

Sd/-

Davendra Ujlayan

VP- Finance

PAN: AAFPU2249C

Place : Gurugram

Dated: June 09, 2021

STATEMENT OF PROFIT AND LOSS FOR YEAR ENDED MARCH 31, 2021

(All amounts are in lakhs unless otherwise stated)

	Note	For the year ended March 31, 2021	For the year ended March 31, 2020
I. Revenue from operations	20	48,741.15	58,783.25
II. Other income	21	351.67	104.43
III. Total income (I + II)		49,092.82	58,887.68
IV Expenses			
Cost of materials consumed	22	16,796.02	24,070.83
Changes in inventories of finished goods and work-in-progress	23	(1,003.57)	1,149.90
Consumptions of Stores		4,458.25	5,568.28
Job work charges		3,308.41	4,057.07
Employee benefit expenses	24	6,141.38	6,128.62
Finance cost	25	5,683.56	5,306.37
Depreciation and amortization expenses	26	4,872.28	5,381.24
Other expenses	27	11,289.09	12,649.63
Total expenses		51,545.42	64,311.94
V Profit/(Loss) before exceptional item and tax (III - IV)		(2,452.60)	(5,424.26)
VI Exceptional Item		-	-
VII Profit/(Loss) before tax (V+VI)		(2,452.60)	(5,424.26)
VIII Tax expense:	28		
(1) Current tax		-	-
(2) Deferred tax		(354.55)	(1,710.79)
(3) Earlier year tax adjustment		154.51	-
IX Net Profit/(Loss) for the year after tax from continuing operations (VII-VIII)		(2,252.56)	(3,713.47)
X Profit / (Loss) from discontinued operation after tax		-	-
XI Profit / (Loss) for the Year		(2,252.56)	(3,713.47)
XII Other comprehensive income			
Item that will not be reclassified to profit or loss	29	58.37	(57.67)
Income tax relating to items that will not be reclassified to profit or loss	28	(20.40)	20.15
Items that will be reclassified to profit or loss	29	-	-
Income tax relating to items that will be reclassified to profit or loss	28	-	-
Other comprehensive income total		37.97	(37.52)
XIII Total Comprehensive income		(2,214.59)	(3,750.99)
XIV Earning per equity share (Face value of Rs 2/-each)	30		
(1) Basic		(2.25)	(3.71)
(2) Diluted		(2.25)	(3.71)
Corporate Information	1		
Basis of preparation of financial statement	2		
Significant accounting policies	3		
The accompanying notes 1 to 48 forms an integral part of the financial statements.			

As per report of even date

For NSBP & Co.

Chartered Accountants

Firm Regn. No. 001075N

Sd/-

Deepak K. Aggarwal

Partner

Membership No. 095541

Place : New Delhi

Dated : June 09, 2021

For & on behalf of the Board of Directors of
Shivam Autotech Limited

Sd/-

Charu Munjal

Whole Time Director

DIN: 03094545

Sd/-

Samta Bajaj

Company Secretary

M No 50269

Sd/-

Neeraj Munjal

Managing Director

DIN : 00037792

Sd/-

Davendra Ujlayan

VP- Finance

PAN: AAFPU2249C

Place : Gurugram

Dated: June 09, 2021

STATEMENT OF CASH FLOW FOR THE YEAR ENDED MARCH 31, 2021

(All amounts are in lakhs unless otherwise stated)

	Year ended March 31, 2021	Year ended March 31, 2020	
A Cash flow from operating activities			
Net Profit Before Taxation and Extraordinary activities	(2,394.24)	(5,481.90)	
Adjustments for:			
Depreciation & Amortisation	4,872.28	5,381.24	
Provision for Doubtful debts/ECL	145.90	452.00	
Profit/(Loss) on sale of Property, Plant & Equipment	32.81	(6.15)	
Intangible assets under development written off	72.30	-	
Government Grant	(0.91)	(0.91)	
Interest income on deposits	(55.51)	(38.73)	
Finance Cost	5,683.56	5,306.36	
Operating profit before working capital changes	8,356.19	5,611.91	
Adjustment for working capital changes:			
(increase)/decrease in trade receivables	259.20	1,795.92	
(increase)/decrease in inventories	(252.58)	2,297.76	
increase/ (decrease) in trade payable	(2,323.27)	(309.25)	
(increase)/decrease in loans & advances/ Other current assets	(465.04)	16.92	
increase/ (decrease) in current liabilities & provisions	1,338.62	1,024.58	
Cash from operations	6,913.11	10,437.84	
Direct taxes (paid)/ refund (net)	251.63	(26.40)	
Net cash from operating activities	7,164.74	10,411.44	
B Cash flow from investing activities			
Purchase of Property, Plant & Equipment including capital work in progress	(2,088.93)	(4,371.34)	
Proceeds from sale of Property, Plant & Equipment	195.84	7.20	
Interest received on deposits	55.51	38.95	
Net cash used in investing activities	(1,837.58)	(4,325.19)	
C Cash flow from financing activities			
Proceeds from/(repayment of) from short term borrowings (net)	(4,106.14)	402.29	
Proceeds from/(repayment of) of long term borrowings (net)	9,265.02	(949.67)	
Repayment of Lease Liabilities	(81.02)	(85.25)	
Interest paid	(5,399.05)	(5,214.46)	
Net cash used in financing activities	(321.18)	(5,847.09)	
Net (decrease)/increase in cash or cash equivalents	5,005.98	239.16	
Cash or cash equivalents at beginning of the year	321.36	82.20	
Cash or cash equivalents at the end of the year	5,327.34	321.36	
Note:			
1) Previous year figures have been regrouped/restated, wherever considered necessary			
2) Figures in bracket represents cash outflow/(losses)			
3) The above cash flow statement has been prepared under the 'Indirect Method' as set out in the Indian Accounting Standard (IND AS-7) 'Statement of Cash Flow'.			
	As at March 31, 2021	As at March 31, 2020	
Components of cash and cash equivalents as at			
Cash and cash equivalents:			
Cash and cash equivalents	5,327.34	321.36	
Cash and cash equivalents	5,327.34	321.36	
4) Changes in liabilities arising from financing activities			
	As at April 01, 2020	Cash Flows	As at the end March 31, 2021
Non-Current Borrowings	25,114.46	9,265.02	34,379.48
Current Borrowings	17,801.45	(4,106.14)	13,695.31
Corporate Information	1		
Basis of preparation of financial statement	2		
Significant accounting policies	3		
The accompanying notes 1 to 48 forms an integral part of the financial statements.			

As per report of even date

For NSBP & Co.

Chartered Accountants
Firm Regn. No. 001075N

Sd/-

Deepak K. Aggarwal

Partner
Membership No. 095541

Place : New Delhi

Dated : June 09, 2021

For & on behalf of the Board of Directors of
Shivam Autotech LimitedSd/-
Neeraj Munjal
Managing Director
DIN : 00037792Sd/-
Davendra Ujlayan
VP- Finance
PAN: AAFPU2249CPlace : Gurugram
Dated: June 09, 2021Sd/-
Charu Munjal
Whole Time Director
DIN: 03094545Sd/-
Samta Bajaj
Company Secretary
M No 50269

STATEMENT OF CHANGES IN EQUITY FOR THE YEAR ENDED MARCH 31 2021

(All amounts are in lakhs unless otherwise stated)

A Equity Share capital

Balance of Equity Share Capital	Balance As at March 31, 2021	Changes during the year	Balance As at March 31, 2020	Changes during the year	Balance As at April 01, 2019
Equity shares of Rs. 2/- each issued, subscribed and fully paid up	2,000	-	2,000	-	2,000

B Other Equity

	Reserves and Surplus			Other comprehensive income	Total
	Capital Redemption Reserve	General Reserve	Retained earnings	Acturial loss/gain on defined benefit obligation	
Balance As at 01.04.2019	5.00	5,068.62	10,200.00	(5.92)	15,267.70
Losses for the year			(3,713.45)		(3,713.45)
Other Comprehensive Losses (net of Income tax)				(37.52)	(37.52)
Balance As at 31.03.2020	5.00	5,068.62	6,486.55	(43.44)	11,516.73
Losses for the year			(2,252.56)		(2,252.56)
Other Comprehensive Income (net of Income tax)				37.97	37.97
Balance As at 31.03.2021	5.00	5,068.62	4,233.99	(5.47)	9,302.14

The description of the nature and purpose of each reserve within equity is as follows:

- i** Retained earnings represents undistributed profits of the Company which can be distributed to its equity shareholders in accordance with the requirement of the Companies Act, 2013.
- ii** Capital redemption reserve was created consequent to redemption of preference share capital, as required under the provisions of the Companies Act, 1956. This reserve shall be utilised in accordance with the provisions of Companies Act, 2013.
- iii** Other Comprehensive Income (OCI) represent the balance in equity for items to be accounted in OCI. OCI is classified into (i) items that will not be reclassified to statement of profit and loss, and (ii) items that will be reclassified to statement of profit and loss.
- iv** General reserve represents the statutory reserve, this is in accordance with Indian corporate law wherein a portion of profit is appropriated to general reserve. Under the erstwhile Companies Act, 1956, it was mandatory to transfer the amount before a company can declare a dividend, however under the Companies Act, 2013, transfer of any amount to general reserve is at the discretion of the company.

Corporate Information

1

Basis of preparation of financial statement

2

Significant accounting policies

3

The accompanying notes 1 to 48 forms an integral part of the financial statement.

As per report of even date

For NSBP & Co.

Chartered Accountants

Firm Regn. No. 001075N

Sd/-

Deepak K. Aggarwal

Partner

Membership No. 095541

Place : New Delhi

Dated : June 09, 2021

**For & on behalf of the Board of Directors of
Shivam Autotech Limited**

Sd/-

Neeraj Munjal
Managing Director
DIN : 00037792

Sd/-

Davendra Ujlayan
VP- Finance
PAN: AAFPU2249C

Place : Gurugram
Dated: June 09, 2021

Sd/-

Charu Munjal
Whole Time Director
DIN: 03094545

Sd/-

Samta Bajaj
Company Secretary
M No A50269

NOTES TO FINANCIAL STATEMENTS FOR THE YEAR ENDED MARCH 31, 2021

(All amounts are in lakhs unless otherwise stated)

1 Corporate Information

Shivam Autotech Limited (the 'Company') was established in the year 1999, and was initially known as Munjal Auto Components till July, 2005. The Company got converted to a separate Public Limited Company w.e.f. 29th July, 2005. In pursuant to the scheme of Demerger & arrangement, the Gurgaon Unit was transferred to Shivam Autotech Limited on August 01, 2005. The Company has been engaged in the manufacturing of Near-Net- Shaped, auto transmission components mainly for Original Equipment Manufacturers (OEMs). The product range includes various types of transmission gears, transmission shafts, spline shafts, plunger, power train components, and employing cold/warm/hot forging techniques. The Company has four state-of-the-art manufacturing facilities, located at Gurgaon, Haridwar, Bengaluru & Rohtak. The Company is listed on the National Stock Exchange and Bombay Stock Exchange of India.

2 Basis of preparation

a) Statement of compliance

The Financial Statements have been prepared in accordance with Indian Accounting Standards (IND AS) as prescribed under Section 133 of the Companies Act, 2013 read with Companies (Indian Accounting Standards) Rules, 2015 and Companies (Indian Accounting Standards) (Amendment) Rules, 2016 and relevant provisions of the Companies Act, 2013. The Financial Statements comply with IND AS notified by Ministry of Company Affairs ("MCA"). The Company has consistently applied the accounting policies used in the preparation for all periods presented.

These financial statements are approved and adopted by board of directors of the Company in their meeting held on Wednesday, June 09, 2021

b) Basis of preparation

The financial statements have been prepared accrual basis on historical cost convention, except as stated otherwise.

Accounting policies have been consistently applied except where a newly issued accounting standard is initially adopted or a revision to an existing accounting standard requires a change in the accounting policy hitherto in use.

c) Functional and presentation currency

The financial statements are presented in Indian National Rupee ('INR'), which is the Company's functional currency. All amounts have been rounded to lakhs upto two decimal places, unless otherwise indicated.

d) Operating cycle

All Assets and Liabilities have been classified as current or non-current as per the Company's normal operating cycle and other criteria set out in the Schedule III to the Companies Act, 2013. Based on the nature of services provided and time between the acquisition of assets for processing and their realization in cash and cash equivalents, the Company has ascertained its operating cycle as 12 months for the purpose of current and non-current classification of assets and liabilities.

e) Use of judgments and estimates

In preparing these financial statements, management has made judgments, estimates and assumptions that affect the application of accounting policies and the reported amounts of assets, liabilities, the disclosures of contingent liabilities and contingent assets at the date of financial statements, income and expenses during the period. Actual results may differ from these estimates. Estimates and underlying assumptions are reviewed on an ongoing basis. Revisions to estimates are recognized prospectively.

Application of accounting policies that require critical accounting estimates and assumption judgments having the most significant effect on the amounts recognized in the financial statements are:

- Measurement of defined benefit obligations;
- Recognition of deferred tax assets & MAT credit entitlement;
- Useful life and residual value of Property, plant and equipment and intangible assets;

NOTES TO FINANCIAL STATEMENTS FOR THE YEAR ENDED MARCH 31, 2021

(All amounts are in lakhs unless otherwise stated)

- Impairment test of financial and non-financial assets;
- Recognition and measurement of provisions and contingencies;
- Fair value measurement of financial instruments;

3 Significant Accounting Policies

The Company has consistently applied the following accounting policies to all periods presented in the financial statements.

a) Property, plant and equipment

i) Recognition and measurement

Items of property, plant and equipment are measured at cost, less accumulated depreciation and accumulated impairment losses, if any.

Cost of an item of property, plant and equipment comprises its purchase price, and any directly attributable cost of bringing the asset to working condition for its intended use.

General and specific borrowing costs directly attributable to the construction of a qualifying asset are capitalized as part of the cost.

If significant parts of an item of property, plant and equipment have different useful lives, then they are accounted for as separate items (major components) of property, plant and equipment. The cost of replacing part of an item of property, plant and equipment or major inspections performed, are recognized in the carrying amount of the item if it is probable that the future economic benefits embodied within the part will flow to the Company and its cost can be measured reliably. The costs of all other repairs and maintenance are recognized in the statement of profit & loss as incurred.

Capital work-in-progress includes cost of property, plant and equipment under installation / under development as at the balance sheet date. Advances paid towards the acquisition of property, plant and equipment outstanding at each balance sheet date is classified as capital advances under other non-current assets.

An item of property, plant and equipment is derecognized when no future economic benefit are expected to arise from the continued use of the asset or upon disposal. Any gain or loss on disposal of an item of property, plant and equipment is recognized in statement of profit or loss.

Subsequent Expenditure

Subsequent expenditures relating to property, plant and equipment is capitalized only when it is probable that future economic benefits associated with these will flow to the company and the costs of the item can be measured reliably. The cost and related accumulated depreciation are eliminated from the financial statements upon sale or retirement of the Property, Plant and Equipment and the resultant gain or losses are recognized in the statement of profit and loss.

ii) Depreciation

Depreciation is calculated on cost of items of property, plant and equipment less their estimated residual values, and is recognized in the statement of profit and loss. Depreciation on property, plant and equipment is provided on Straight Line Method at the rates determined on the basis of useful life of the assets as prescribed in Schedule II of the Companies Act, 2013.

	Useful Life as per Schedule II of Companies Act 2013 (in years)
- Plant & Machinery	15
- Buildings	30
- Computers	3
- Office equipment	5
- Furniture & fixtures	10
- Vehicles	8
- Lease hold Improvements	Amortised over the period of lease

NOTES TO FINANCIAL STATEMENTS FOR THE YEAR ENDED MARCH 31, 2021

(All amounts are in lakhs unless otherwise stated)

Depreciation on additions to or on disposal of assets is calculated on pro-rata basis i.e. from (upto) the date on which the property, plant and equipment is available for use (disposed off).

Property, Plant and Equipment individually costing below Rs. 5,000 are fully depreciated during the year they are put to use.

b) Intangible assets

i) Recognition & measurement and amortization

Intangible Assets are recognized, if the future economic benefits attributable to the assets are expected to flow to the company and cost of the asset can be measured reliably. All other expenditure is expensed as incurred. The same are amortized over the expected duration of benefits. Such intangible assets are measured at cost less any accumulated amortization and impairment losses, if any and are amortized over their respective individual estimated useful life on straight line method.

The estimated useful lives are as follows:

Computer Software 4 years

The amortization period and the amortization method for an intangible asset with a finite useful life are reviewed at least at the end of each reporting period and adjusted prospectively, if appropriate.

Intangible assets are tested for impairment when there are indications that the carrying value may not be recoverable. All impairment losses are recognised immediately in profit or loss.

An item of intangible asset is derecognised when no future economic benefit are expected to arise from the continued use of the asset or upon disposal.

Any gain or loss on disposal of an item of intangible assets is recognized in statement of profit or loss.

c) Impairment of non-financial assets

At each reporting date, the Company reviews the carrying amounts of its non-financial assets (other than deferred tax assets) to determine whether there is any indication on impairment. If any such indication exists, then the asset's recoverable amount is estimated.

For impairment testing, assets that do not generate independent cash flows are grouped together into the smallest group of assets that generates cash inflows from continuing use that are largely independent of the cash inflows of other assets or Cash Generating Units ('CGUs').

The recoverable amount of an asset or CGU is the greater of its value in use and its fair value less costs to sell. Value in use is based on the estimated future cash flows, discounted to their present value using a pre-tax discount rate that reflects current market assessments of the time value of money and the risks specific to the asset or CGU.

An impairment loss is recognized if the carrying amount of an asset or CGU exceeds its estimated recoverable amount. Impairment losses are recognized in the statement of profit and loss.

In respect of assets for which impairment loss has been recognized in prior periods, the company reviews at each reporting date whether there is any indication that the loss has decreased or no longer exists. An impairment loss is reversed if there has been a change in the estimates used to determine the recoverable amount. Such a reversal is made only to the extent that the asset's carrying amount does not exceed the carrying amount that would have been determined, net of depreciation or amortization, if no impairment loss had been recognized.

After impairment, depreciation is provided on the revised carrying amount of the assets over its remaining useful life.

d) Financial instruments

i) Initial recognition

The Company recognizes financial assets and financial liabilities when it becomes a party to the contractual provisions of the instrument. All financial assets and liabilities are recognized at fair value on initial recognition, except for trade receivables which are initially measured at **fair value of the consideration received or**

NOTES TO FINANCIAL STATEMENTS FOR THE YEAR ENDED MARCH 31, 2021

(All amounts are in lakhs unless otherwise stated)

receivable. Transaction costs that are directly attributable to the acquisition or issue of financial assets and financial liabilities, that are not at fair value through profit or loss, are added to the fair value on initial recognition. Regular way purchase and sale of financial assets are accounted for at trade date.

ii) Subsequent measurement

(i) *Financial assets carried at amortized cost*

A financial asset is subsequently measured at amortized cost if it is held within a business model whose objective is to hold the asset in order to collect contractual cash flows and the contractual terms of the financial asset give rise on specified dates to cash flows that are solely payments of principal and interest on the principal amount outstanding. When the financial asset is derecognized or impaired, the gain or loss is recognized in the statement of profit and loss.

(ii) *Financial assets at fair value through other comprehensive income*

A financial asset is subsequently measured at fair value through other comprehensive income if it is held within a business model whose objective is achieved by both collecting contractual cash flows and selling financial assets and the contractual terms of the financial asset give rise on specified dates to cash flows that are solely payments of principal and interest on the principal amount outstanding. Movements in the carrying amount are taken through OCI, except for the recognition of impairment gains or losses, interest revenue and foreign exchange gains and losses which are recognized in profit and loss.

When the financial asset is derecognized, the cumulative gain or loss previously recognized in OCI is reclassified from equity to profit and loss. Equity instruments are subsequently measured at fair value. On initial recognition of an equity investment that is not held for trading, the Company may irrevocably elect to present subsequent changes in the investment's fair value in OCI (designated as FVOCI – equity investment). This election is made on an investment by investment basis. Fair value gains and losses recognized in OCI are not reclassified to profit and loss.

(iii) *Financial assets at fair value through profit or loss*

A financial asset which is not classified in any of the above categories are subsequently fair valued through profit or loss.

(iv) *Financial liabilities*

Financial liabilities are subsequently carried at amortized cost using the effective interest method. For trade and other payables maturing within one year from the Balance Sheet date, the carrying amounts approximate fair value due to the short maturity of these instruments.

iii) Impairment of financial assets

Financial assets, other than those at FVTPL, are assessed for indicators of impairment at the end of each reporting period. The Company recognizes a loss allowance for expected credit losses on financial asset. In case of trade receivables, the Company follows the simplified approach permitted by Ind AS 109 – Financial Instruments for recognition of impairment loss allowance. The application of simplified approach does not require the Company to track changes in credit risk. The Company calculates the expected credit losses on trade receivables using a provision matrix on the basis of its historical credit loss experience.

iv) Derecognition

Financial Assets

Company derecognizes a financial asset when the contractual rights to the cash flows from the financial asset expire or it transfers the rights to receive the contractual cash flows in a transaction in which substantially all of the risks and rewards of ownership of the financial asset are transferred or in which the company neither transfers nor retains substantially all of the risks and rewards of ownership and does not retain control of the financial asset.

NOTES TO FINANCIAL STATEMENTS FOR THE YEAR ENDED MARCH 31, 2021

(All amounts are in lakhs unless otherwise stated)

If the company enters into transactions whereby it transfers assets recognized on its balance sheet, but retains either all or substantially all of the risks and rewards of the transferred assets, the transferred assets are not derecognized.

Financial liabilities

The company derecognizes a financial liability when its contractual obligations are discharged or cancelled, or expire.

v) Reclassification of financial assets and financial liabilities

The company determines classification of financial assets and liabilities on initial recognition. After initial recognition, no reclassification is made for financial assets which are equity instruments and financial liabilities. For financial assets which are debt instruments, a reclassification is made only if there is a change in the business model for managing those assets. Changes to the business model are expected to be infrequent. The Company's senior management determines change in the business model as a result of external or internal changes which are significant to the Company's operations. Such changes are evident to external parties. A change in the business model occurs when the Company either begins or ceases to perform an activity that is significant to its operations. If the company reclassifies financial assets, it applies the reclassification prospectively from the reclassification date which is the first day of the immediately next reporting period following the change in business model. The company does not restate any previously recognized gains, losses (including impairment gains or losses) or interest.

vi) Derivative financial instruments

The Company uses derivative financial instruments, such as forward currency contracts to hedge its foreign currency risks. Derivative financial instruments are initially recognized at fair value on the date a derivative contract is entered into and are subsequently re-measured at their fair value at the end of each period. The method of recognizing the resulting gain or loss depends on whether the derivative is designated as a hedging instrument, and if so, on the nature of the item being hedged. Any gains or losses arising from changes in the fair value of derivatives are taken directly to statement of profit or loss.

vii) Offsetting

Financial assets and financial liabilities are offset and the net amount presented in the balance sheet when, and only when, the company has a legally enforceable right to set off the amounts and it intends either to settle them on a net basis or to realize the asset and settle the liability simultaneously.

e) Fair value measurement

Fair value is the price that would be received to sell an asset or paid to transfer a liability in an orderly transaction between market participants at the measurement date, regardless of whether that price is directly observable or estimated using other valuation technique. In estimating the fair value of an asset or a liability, the Company takes into account the characteristics of the asset or liability if market participants would take those characteristics into account when pricing the asset or liability at the measurement date.

Fair values for measurement and/ or disclosure purposes are categorized into Level 1, 2, or 3 based on the degree to which the inputs to the fair value measurements are observable and the significance of the inputs to the fair value measurement in its entirety, which are described as follows:

Level 1 - This includes financial instruments measured using quoted prices.

Level 2 - The fair value of financial instruments that are not traded in an active market is determined using valuation techniques which maximize the use of observable market data and rely as little as possible on entity-specific estimates. If all significant inputs required to fair value an instrument are observable, the instrument is included in level 2. Inputs other than quoted prices included within Level 1 that are observable for the asset or liability, either directly (i.e. as prices) or indirectly (i.e. Derived from prices).

Level 3 - If one or more of the significant inputs is not based on observable market data, the instrument is included in level 3.

NOTES TO FINANCIAL STATEMENTS FOR THE YEAR ENDED MARCH 31, 2021

(All amounts are in lakhs unless otherwise stated)

f) Provisions, Contingent Liabilities and Contingent Assets

A provision is recognized if, as a result of a past event, the Company has a present legal or constructive obligation that can be estimated reliably, and it is probable that an outflow of economic benefits will be required to settle the obligation. If the effect of the time value of money is material, provisions are determined by discounting the expected future cash flows at a pre-tax rate that reflects current market assessments of the time value of money and the risks specific to the liability. Where discounting is used, the increase in the provision due to the passage of time is recognized as a finance cost.

Contingent Liability is disclosed after careful evaluation of facts, uncertainties and possibility of reimbursement, unless the possibility of an outflow of resources embodying economic benefits is remote. Contingent liabilities are not recognized but are disclosed in notes. Contingent assets are not disclosed in the financial statements unless an inflow of economic benefits is probable.

g) Revenue Recognition

Revenue is recognized to the extent that it is probable that the economic benefits will flow to the Company and the revenue can be reliably measured.

i) Sale of goods-

Sales is accounted for upon dispatch of goods from the factory when the risks and rewards of ownership are transferred to the buyer.

Ind AS 115 provides for a five step model for the analysis of Revenue transactions. The model specifies that revenue should be recognised when (or as) an entity transfer control of goods or services to a customer at the amount to which the entity expects to be entitled. Further the standard requires enhanced disclosures about the nature, amount, timing, and uncertainty of revenue and cash flows arising from the entity's contracts with customers.

Revenue is recognized upon transfer of control of promised products or services to customers in an amount that reflects the consideration we expect to receive in exchange for those products or services.

ii) Dividends

Dividend is recognized when the shareholders' right to receive payment is established by the balance sheet date.

iii) Insurance claim

Claims lodged with the insurance companies are accounted on accrual basis to the extent these are measurable and ultimate collection is reasonably certain.

iv) Interest Income

Interest income is recognised on time proportion basis taking in to account the amount outstanding and the rate applicable.

v) Government Grant & Subsidies

Grant/subsidies is recognised when there is reasonable assurance the Grant/subsidy will be received and all attaching condition will be complied with.

h) Employee Benefits

i) Short term employee benefits

Short-term employee benefits are expensed as the related service is provided. A liability is recognized for the amount expected to be paid if the Company has a present legal or constructive obligation to pay this amount as a result of past service provided by the employee and the obligation can be estimated reliably.

ii) Defined contribution plans

Employees benefits in the form of the Company's contribution to Provident Fund, Family Pension scheme and Employees State Insurance are defined contribution schemes. The Company recognizes contribution payable to these schemes as an expense, when an employee renders the related service.

NOTES TO FINANCIAL STATEMENTS FOR THE YEAR ENDED MARCH 31, 2021

(All amounts are in lakhs unless otherwise stated)

If the contribution payable exceeds contribution already paid, the deficit payable is recognized as a liability (accrued expense), after deducting any contribution already paid. If the contribution already paid exceeds the contribution due for service before the end of the reporting period. The Company recognize that excess as an asset (prepaid expense) to the extent that the prepayment will lead to, for example, a reduction in future payments or a cash refund.

iii) Defined benefit plans

Retirement benefits in the form of gratuity are considered as defined benefit plans. The Company's net obligation in respect of defined benefit plans is calculated by estimating the amount of future benefit that employees have earned in the current and prior periods, discounting that amount and deducting the fair value of any plan assets.

The company provides for its gratuity liability based on actuarial valuation of the gratuity liability as at the Balance Sheet date, based on Projected Unit Credit Method, carried out by an independent actuary. The Company contributes to the gratuity fund, which are recognized as plan assets. The defined benefit obligation as reduced by fair value of plan assets is recognized in the Balance Sheet.

When the calculation results in a potential asset for the company, the recognized asset is limited to the present value of economic benefits available in the form of any future refunds from the plan or reductions in future contributions to the plan. To calculate the present value of economic benefits, consideration is given to any applicable minimum funding requirements.

Remeasurement of the net defined benefit liability, which comprise actuarial gains and losses, the return on plan assets (excluding interest) and the effect of the asset ceiling (if any, excluding interest), are recognized immediately in Other Comprehensive Income. Net interest expense (income) on the net defined liability (assets) is computed by applying the discount rate, used to measure the net defined liability (asset), to the net defined liability (asset) at the start of the financial year after taking into account any changes as a result of contribution and benefit payments during the year. Net interest expense and other expenses related to defined benefit plans are recognized in statement of profit or loss.

When the benefits of a plan are changed or when a plan is curtailed, the resulting change in benefit that relates to past service or the gain or loss on curtailment is recognized immediately in statement of profit or loss. The company recognizes gains and losses on the settlement of a defined benefit plan when the settlement occurs.

iv) Other long-term employee benefits

Employee benefits in the form of long term compensated absences are considered as long term employee benefits. The Company's net obligation in respect of long-term employee benefits is the amount of future benefit that employees have earned in return for their service in the current and prior periods. That benefit is discounted to determine its present value. Remeasurements are recognized in profit or loss in the period in which they arise.

The liability for long term compensated absences are provided based on actuarial valuation as at the Balance Sheet date, based on Projected Unit Credit Method, carried out by an independent actuary.

i) Valuation of inventories

- i) Finished goods are valued at lower of cost or net realizable value. Scrap is valued at net realizable value. cost includes direct materials and labour and a proportion of manufacturing overheads based on normal operating capacity.
- ii) Work in progress is valued at raw material cost including proportionate production overheads.
- iii) Stores, spares and raw materials are valued at lower of cost or net realizable value. However, materials & other items held for use in the production of inventories are not written below cost if the finished products in which they will be incorporated are expected to be sold at or above cost. cost of purchases is assessed on first in first out (FIFO) method.

NOTES TO FINANCIAL STATEMENTS FOR THE YEAR ENDED MARCH 31, 2021

(All amounts are in lakhs unless otherwise stated)

- iv) Net realizable value is the estimated selling price in the ordinary course of business, less estimated costs of completion and estimated costs necessary to make the sale.

j) Foreign Exchange Transactions / Translations / Hedge Accounting

Standalone financial statements have been presented in Indian Rupees (₹), which is the Company's functional and presentation currency.

- Initial recognition

Foreign currency transactions are recorded on initial recognition in the functional currency, using the exchange rate at the date of the transaction.

- Conversion

Foreign currency monetary items are retranslated using the exchange rate prevailing at the reporting date. Non-monetary items, which are measured in terms of historical cost denominated in a foreign currency, are reported using the exchange rate at the date of the transaction. Non-monetary items, which are measured at fair value or other similar valuation denominated in a foreign currency, are translated using the exchange rate at the date when such value was determined.

- Exchange differences

The gain or loss arising on translation of non-monetary items measured at fair value is treated in line with the recognition of the gain or loss on the change in fair value of the item (i.e., translation differences on items whose fair value gain or loss is recognized in OCI or profit or loss are also recognized in OCI or profit or loss, respectively).

k) Borrowing costs

Borrowing costs are interest and other ancillary costs (including exchange differences relating to foreign currency borrowings to the extent that they are regarded as an adjustment to interest costs) incurred in connection with the borrowing of funds. General and specific borrowing costs attributable to acquisition and construction of any qualifying asset (one that takes a substantial period of time to get ready for its designated use or sale) are capitalized until such time as the assets are substantially ready for their intended use or sale, and included as part of the cost of that asset. All the other borrowing costs are recognized in the Statement of Profit and Loss within Finance costs of the period in which they are incurred.

l) Income tax

Income tax expense comprises current and deferred tax. It is recognized in profit or loss except to the extent that it relates to items recognized directly in equity or in Other Comprehensive Income.

i) Current tax

Current tax comprises the expected tax payable or receivable on the taxable income or loss for the year after taking credit of the benefits available under the Income Tax Act and any adjustment to the tax payable or receivable in respect of previous years. It is measured using tax rates enacted or substantively enacted at the reporting date. Current tax assets and liabilities are offset only if, the Company:

- has a legally enforceable right to set off the recognized amounts; and
- intends either to settle on a net basis, or to realize the asset and settle the liability simultaneously.

ii) Deferred tax

Deferred tax is the tax expected to be payable or recoverable on differences between the carrying values of assets and liabilities in the financial statements and the corresponding tax bases used in the computation of taxable profit and is accounted for using the balance sheet liability method. Deferred tax liabilities are generally recognized for all taxable temporary differences. In contrast, deferred tax assets are only recognized to the extent that it is probable that future taxable profits will be available against which the temporary differences can be utilized.

NOTES TO FINANCIAL STATEMENTS FOR THE YEAR ENDED MARCH 31, 2021

(All amounts are in lakhs unless otherwise stated)

The carrying value of deferred tax assets is reviewed at the end of each reporting period and reduced to the extent that it is no longer probable that sufficient taxable profits will be available to allow all or part of the asset to be recovered.

Deferred tax is calculated at the tax rates that are expected to apply in the period when the liability is settled or the asset is realized based on the tax rates and tax laws that have been enacted or substantially enacted by the end of the reporting period. The measurement of deferred tax liabilities and assets reflects the tax consequences that would follow from the manner in which the Company expects, at the end of the reporting period, to cover or settle the carrying value of its assets and liabilities.

Deferred tax assets and liabilities are offset only if:

- i) The entity has a legally enforceable right to set off current tax assets against current tax liabilities; and
- ii) The deferred tax assets and the deferred tax liabilities relate to income taxes levied by the same taxation authority on the same taxable entity.

Deferred tax assets include Minimum Alternate Tax (MAT) paid in accordance with the tax laws in India, which is likely to give future economic benefits in the form of availability of set off against future income tax liability. MAT is recognized as deferred tax assets in the Balance Sheet when the asset can be measured reliably and it is probable that the future economic benefit associated with the asset will be realized.

m) Segment Reporting

The Company's operating businesses are organized and managed separately according to the nature of products manufactured and services provided, with each segment representing a strategic business unit that offers different products. The analysis of geographical segments is based on the areas in which major operating divisions of the Company operate. The reportable segments have been identified based on the significant components of the enterprise for which discrete financial information is available and are reviewed by the Chief operating decision maker (CODM) to assess the performance and allocate resources to the operating segments. Refer Note -35.

n) Cash and cash equivalents

Cash and cash equivalents comprise cash at bank and on hand and short-term deposits with original maturities of three months or less that are readily convertible to known amounts of cash and which are subject to an insignificant risk of changes in value.

o) Cash flow statement

Cash flows are reported using the indirect method as explained in the Accounting Standard on Statement of Cash Flows (Ind AS - 7), whereby profit for the period is adjusted for the effects of transactions of a non-cash nature, any deferrals or accruals of past or future operating cash receipts or payments and item of income or expenses associated with investing or financing cash flows. The cash flows from operating, investing and financing activities of the Company are segregated.

p) Ind AS - 116 Lease

Ind AS 116 requires lessees to determine the lease term as the non-cancellable period of a lease adjusted with any option to extend or terminate the lease, if the use of such option is reasonably certain. The Company makes an assessment on the expected lease term on a lease-by-lease basis and thereby assesses whether it is reasonably certain that any options to extend or terminate the contract will be exercised. In evaluating the lease term, the Company considers factors such as any significant leasehold improvements undertaken over the lease term, costs relating to the termination of the lease and the importance of the underlying asset to Company's operations taking into account the location of the underlying asset and the availability of suitable alternatives. The lease term in future periods is reassessed to ensure that the lease term reflects the current economic circumstances. After considering current and future economic conditions, the company has concluded that no changes are required to lease period relating to the existing lease contracts.

NOTES TO FINANCIAL STATEMENTS FOR THE YEAR ENDED MARCH 31, 2021

(All amounts are in lakhs unless otherwise stated)

The Company as a lessee

The Company's lease asset classes primarily consist of leases for buildings. The Company assesses whether a contract contains a lease, at inception of a contract. A contract is, or contains, a lease if the contract conveys the right to control the use of an identified asset for a period of time in exchange for consideration. To assess whether a contract conveys the right to control the use of an identified asset, the Company assesses whether: (i) the contract involves the use of an identified asset (ii) the Company has substantially all of the economic benefits from use of the asset through the period of the lease and (iii) the Company has the right to direct the use of the asset.

At the date of commencement of the lease, the Company recognizes a right-of-use asset ("ROU") and a corresponding lease liability for all lease arrangements in which it is a lessee, except for leases with a term of twelve months or less (short-term leases) and low value leases. For these short-term and low value leases, the Company recognizes the lease payments as an operating expense on a straight-line basis over the term of the lease.

Certain lease arrangements include the options to extend or terminate the lease before the end of the lease term. ROU assets and lease liabilities includes these options when it is reasonably certain that they will be exercised.

The right-of-use assets are initially recognized at cost, which comprises the initial amount of the lease liability adjusted for any lease payments made at or prior to the commencement date of the lease plus any initial direct costs less any lease incentives. They are subsequently measured at cost less accumulated depreciation and impairment losses.

Right-of-use assets are depreciated from the commencement date on a straight-line basis over the shorter of the lease term and useful life of the underlying asset. Right of use assets are evaluated for recoverability whenever events or changes in circumstances indicate that their carrying amounts may not be recoverable. For the purpose of impairment testing, the recoverable amount (i.e. the higher of the fair value less cost to sell and the value-in-use) is determined on an individual asset basis unless the asset does not generate cash flows that are largely independent of those from other assets. In such cases, the recoverable amount is determined for the Cash Generating Unit (CGU) to which the asset belongs.

The lease liability is initially measured at amortized cost at the present value of the future lease payments. The lease payments are discounted using the interest rate implicit in the lease or, if not readily determinable, using the incremental borrowing rates in the country of domicile of these leases. Lease liabilities are re-measured with a corresponding adjustment to the related right of use asset if the Company changes its assessment if whether it will exercise an extension or a termination option. Lease liability and ROU asset have been separately presented in the Balance Sheet and lease payments have been classified as financing cash flows.

The Company as a lessor

Leases for which the Company is a lessor is classified as a finance or operating lease. Whenever the terms of the lease transfer substantially all the risks and rewards of ownership to the lessee, the contract is classified as a finance lease. All other leases are classified as operating leases. When the Company is an intermediate lessor, it accounts for its interests in the head lease and the sublease separately. The sublease is classified as a finance or operating lease by reference to the right-of-use asset arising from the head lease. For operating leases, rental income is recognized on a straight line basis over the term of the relevant lease.

q) Earning per share

Basic earnings per share are calculated by dividing the net profit or loss for the period attributable to equity shareholders by the weighted average number of equity shares outstanding during the year.

For the purpose of calculating diluted earnings per share, the net profit or loss for the period attributable to equity shareholders and the weighted average number of shares outstanding during the period are adjusted for the effects of all dilutive potential equity shares.

NOTES TO FINANCIAL STATEMENTS FOR THE YEAR ENDED MARCH 31, 2021

(All amounts are in lakhs unless otherwise stated)

r) Government grants

Government grants are recognized at fair value when there is reasonable assurance that the grant would be received and the Company would comply with all the conditions attached with them. Government grants related to PPE are treated as deferred income (included under non-current liabilities with current portion considered under current liabilities) and are recognized and credited in the Statement of Profit and Loss on a systematic and rational basis over the estimated useful life of the related asset and included under "Other operating income". Government grants related to revenue nature are recognized on a systematic basis in the Statement of profit and loss over the periods necessary to match them with the related costs which they are intended to compensate and are adjusted with the related expenditure. If not related to a specific expenditure, it is taken as income and presented under "Other operating income".

s) Recent Pronouncements

On March 24, 2021, the Ministry of Corporate Affairs ("MCA") through a notification, amended Schedule III of the Companies Act, 2013. The amendments revise Division I, II and III of Schedule III and are applicable from April 1, 2021. Key amendments relating to Division II which relate to companies whose financial statements are required to comply with Companies (Indian Accounting Standards) Rules 2015 are:

Balance Sheet:

- (i) Lease liabilities should be separately disclosed under the head 'financial liabilities', duly distinguished as current or non-current.
- (ii) Certain additional disclosures in the statement of changes in equity such as changes in equity share capital due to prior period errors and restated balances at the beginning of the current reporting period.
- (iii) Specified format for disclosure of shareholding of promoters.
- (iv) Specified format for ageing schedule of trade receivables, trade payables, capital work-in-progress and intangible asset under development.
- (v) If a company has not used funds for the specific purpose for which it was borrowed from banks and financial institutions, then disclosure of details of where it has been used.
- (vi) Specific disclosure under 'additional regulatory requirement' such as compliance with approved schemes of arrangements, compliance with number of layers of companies, title deeds of immovable property not held in name of company, loans and advances to promoters, directors, key managerial personnel (KMP) and related parties, details of benami property held etc.

Statement of profit and loss:

- (vii) Additional disclosures relating to Corporate Social Responsibility (CSR), undisclosed income and crypto or virtual currency specified under the head 'additional information' in the notes forming part of the standalone financial statements.

The amendments are extensive and the Company will evaluate the same to give effect to them as required by law.

NOTES TO FINANCIAL STATEMENTS FOR THE YEAR ENDED MARCH 31, 2021

(All amounts are in lakhs unless otherwise stated)

4 Property, plant & equipment

Particulars	Tangible Asset										Intangible assets	Grand Total	
	Freehold Land	Building	Plant & Equipment	Computers	Office equipment	Furniture & fixtures	Vehicles	Lease hold Improvements	Total Tangible assets				
Gross Block													
As at 01 April 2019	5,754.84	10,744.28	63,882.70	334.12	354.91	393.53	644.43	149.58	82,258.39	588.61	82,847.00		
Additions		274.53	1,933.51	11.18	4.19	57.19	(70.71)	140.97	2,421.57	19.47	2,441.04		
Disposals									(70.71)		(70.71)		
As at 31 March 2020	5,754.84	11,018.81	65,816.21	345.30	359.10	450.72	573.72	290.55	84,609.25	608.08	85,217.33		
Additions	-	-	3,274.05	0.06	0.48	14.83	-	55.35	3,344.77	10.90	3,355.67		
Disposals	-	-	(257.70)	-	(8.48)	-	(10.02)	-	(276.20)	-	(276.20)		
As at 31 March 2021	5,754.84	11,018.81	68,832.56	345.36	351.10	465.55	563.70	345.90	87,677.82	618.98	88,296.80		
Depreciation/Amortisation													
As at 01 April, 2019	-	1,742.04	32,807.56	273.88	275.19	195.56	356.82	89.81	35,740.84	422.42	36,163.26		
Charge for the year		375.90	4,601.08	32.08	27.11	31.87	69.55	21.04	5,158.64	74.83	5,233.47		
Disposals							(69.66)		(69.66)		(69.66)		
As at 31 March 2020	-	2,117.94	37,408.64	305.96	302.30	227.43	356.71	110.85	40,829.82	497.25	41,327.07		
Charge for the year		371.00	4,166.00	19.53	19.60	29.81	58.18	28.15	4,692.27	63.51	4,755.78		
Disposals			(29.47)		(8.11)		(9.97)		(47.55)		(47.55)		
As at 31 March 2021	-	2,488.94	41,545.17	325.49	313.79	257.24	404.92	139.00	45,474.54	560.76	46,035.30		
Net Block													
As at 31 March, 2020	5,754.84	8,900.87	28,407.57	39.34	56.80	223.29	217.01	179.70	43,779.43	110.83	43,890.26		
As at 31 March, 2021	5,754.84	8,529.87	27,287.39	19.87	37.31	208.31	158.78	206.90	42,203.28	58.22	42,261.50		

Notes:-

(i) Lease hold improvements have been amortised over period of lease.

(ii) Refer note no. 39 for charges.

(iii) **Impairment Review**

Assets are tested for impairment whenever there are any internal or external indicators of impairment. Impairment test is performed at the level of each Cash Generating Unit ('CGU') or groups of CGUs within the Company at which the assets are monitored for internal management purposes, within an operating segment. The impairment assessment is based on higher of value in use and value from sale calculations. During the year, the testing did not result in any impairment in the carrying amount of other assets. The measurement of the cash generating units' value in use is determined based on financial plans that have been used by management for internal purposes. The planning horizon reflects the assumptions for short to- mid-term market conditions.

Key assumptions used in value-in-use calculations are:-

(i) Operating margins (Earnings before interest and taxes), (ii) Discount Rate, (iii) Growth Rates and (iv) Capital Expenditure

NOTES TO FINANCIAL STATEMENTS FOR THE YEAR ENDED MARCH 31, 2021

(All amounts are in lakhs unless otherwise stated)

5.1 Right-of-use assets	Amounts	
Gross Block (at cost)		
As at 01.04.2019		-
Additions		1,072.29
Disposals		-
As at 31.03.2020		1,072.29
Additions		-
Disposals		126.12
As at 31.03.2021		946.17
Amortisation		
As at 01.04.2019		-
Charge for the year		147.77
Disposals		-
As at 31.03.2020		147.77
Charge for the year		116.51
Disposals		
As at 31.03.2021		264.28
Net Block as at 31.03.2021		681.89
Net Block as at 31.03.2020		924.52

5.2 Capital- Work-In-Progress (CWIP)	As at March 31, 2021	As at March 31, 2020
Opening CWIP	2,753.72	27.48
Add: Additions during the year	-	3,812.28
Less: capitalised during the year	2,707.10	1,086.04
Total Capital Work in Progress*	46.62	2,753.72

*Includes pre-operative expenditure pending capitalisation of Rs. Nil (Previous year Rs. Nil)

5.3 Intangible Assets Under Development	As at March 31, 2021	As at March 31, 2020
Intangible Assets under Development		
Opening	72.30	41.94
Add: Additions during the year	47.00	30.36
Less: Written off during the year	72.30	-
	47.00	72.30

6 Financial Asset: Non Current

6.1 Loans	As at March 31, 2021	As at March 31, 2020
Unsecured considered good		
-Security Deposits	629.78	650.80
Total	629.78	650.80

6.2 Other Financial Assets	As at March 31, 2021	As at March 31, 2020
Bank Deposit with Maturity above 12 months including interest thereon	715.72	355.73
Total	715.72	355.73

*Out of total Rs. 232.58 Lakhs (PY Rs. 235.02 Lakhs) is held as margin money with government departments and others.

NOTES TO FINANCIAL STATEMENTS FOR THE YEAR ENDED MARCH 31, 2021

(All amounts are in lakhs unless otherwise stated)

7	Deferred Tax Liability/assets	As at March 31, 2021	As at March 31, 2020
	Deferred tax liability	(3,707.79)	(3,544.07)
	Deferred tax assets	5,697.04	5,199.16
	MAT Credit Entitlement	1,680.06	1,680.06
	Total	3,669.31	3,335.15

(i) Movement in deferred tax items

FY 2020-21	Balance as on 01-04-2020	Recognised in Statement of Profit & Loss	Recognised in other comprehensive income	Balance as on 31-03-2021
Deferred tax (liability)/asset in relation to Depreciation on Property, plant & equipment	(4,092.40)	396.60		(3,695.80)
Provision for doubtful trade receivables	166.94	33.05		199.98
Borrowings - Processing Fees	(42.79)	30.79		(12.00)
Expenses allowed on payment basis	415.84	(105.88)	(20.40)	289.56
Recognition of DTA on unabsorbed depreciation	5,207.50	-		5,207.50
Deferred tax Assets/(Liability)	1,655.09	354.55	(20.40)	1,989.25
MAT Credit Entitlement	1,680.06			1,680.06
Net Deferred tax Assets/ (Liability)	3,335.15	354.55	(20.40)	3,669.31

FY 2019-20	Balance as on 01-04-2019	Recognised in Statement of Profit & Loss	Recognised in other comprehensive income	Balance as on 31-03-2020
Deferred tax (liability)/asset in relation to Depreciation on Property, plant & equipment	(3,737.58)	(354.82)		(4,092.40)
Provision for doubtful trade receivables	9.00	157.94		166.94
Borrowings - Processing Fees	(25.63)	(17.16)		(42.79)
Expenses allowed on payment basis	188.60	247.39	(20.15)	415.84
Recognition of DTA on unabsorbed depreciation	3,530.06	1,677.44		5,207.50
Deferred tax Assets/(Liability)	(35.55)	1,710.79	(20.15)	1,655.09
MAT Credit Entitlement	1,680.06			1,680.06
Net Deferred tax Assets/ (Liability)	1,644.51	1,710.79	(20.15)	3,335.15

As a matter of prudence, the Company continues to carry Deferred tax assets of Rs. 5,697.04 lakhs as at March 31, 2021 (restricted to deferred tax assets on unabsorbed depreciation of Rs. 5,207.50 Lakhs created up to March 31, 2020). In past the company had incurred losses mainly due to depress in the automobile sector, however the management is hopeful to earn adequate profits in future to utilise deferred tax assets.

NOTES TO FINANCIAL STATEMENTS FOR THE YEAR ENDED MARCH 31, 2021

(All amounts are in lakhs unless otherwise stated)

8	Income tax asset (Net)	As at March 31, 2021	As at March 31, 2020
	Income Tax Assets		
	Tax refund receivable (net of provision)	49.60	455.73
	Total	49.60	455.73

9	Other Non Current Assets	As at March 31, 2021	As at March 31, 2020
	Unsecured considered good		
	- Capital advance		
	Suppliers / Contractors	447.11	81.14
	- Balance deposit with government authorities under protest	27.43	27.42
	Total	474.54	108.56

10	Inventories*	As at March 31, 2021	As at March 31, 2020
	(Valued at cost or net realisable value, unless otherwise stated) (Refer note i of note no 3) (As taken, valued and certified by the management)		
	a) Raw materials	1,241.01	1,485.60
	b) Work-in-progress	3,128.49	2,326.43
	c) Finished goods	407.78	224.56
	d) Stores and spares	3,970.49	4,476.89
	e) Others (Scrap)	103.86	85.57
	* Refer note no 39-I & II for charges		
	Total	8,851.63	8,599.05

i) **Inventory Physical verification and inventory consumption**

Due to non- updation of Bill of material (BOM), setting up of new production facilities and expansion of the customer base, quantitative variance were observed between physical and book records. Variance as observed has been considered as consumption of material for the preparation of the financial statements.

11	Financial Asset: Current	As at March 31, 2021	As at March 31, 2020
11.1	Trade Receivables		
	Unsecured, Considered good		
	- From related party	25.10	-
	- From others	6,713.31	7,143.51
	- Unsecured, Considered doubtful	623.64	477.75
	Less: Allowance for doubtful debts*	(623.64)	(477.75)
	Total	6,738.41	7,143.51

Refer note no.40 (B)

*Refer note no-39 (I), II & 44.

NOTES TO FINANCIAL STATEMENTS FOR THE YEAR ENDED MARCH 31, 2021

(All amounts are in lakhs unless otherwise stated)

11.2 Cash & cash equivalents	As at March 31, 2021	As at March 31, 2020
Balances with banks		
- in Current Accounts*	5,320.21	316.75
Cash in hand	7.13	4.61
Total	5,327.34	321.36
*Refer note 14.1 (iii)		
11.3 Bank Balance, other than cash & cash equivalents	As at March 31, 2021	As at March 31, 2020
Earmarked balance		
- unpaid dividend	23.44	31.19
Other Balance		
- in fixed deposit (original maturity exceeding three months but upto one year)*	844.61	383.42
Total	868.05	414.61
*It includes fixed deposits lodged as security with banks for credit limit		
11.4 Loans	As at March 31, 2021	As at March 31, 2020
Unsecured considered good		
Loans to employees	16.76	37.32
	16.76	37.32
11.5 Others Financial Asset	As at March 31, 2021	As at March 31, 2020
Unsecured considered good		
Unbilled Revenue	157.61	27.26
Other Advances	144.67	-
Total	302.28	27.26
12 Other Current Asset	As at March 31, 2021	As at March 31, 2020
Prepaid Expenses	167.29	168.29
Advances to employee	7.54	2.02
Advances other than capital advances	1,234.77	928.87
Balance with government authorities	81.68	950.90
Power Open Access Receivable	71.98	96.71
Budgetary support from Government	1,149.49	1,149.49
Others	47.92	46.23
Total	2,760.67	3,342.51
13 Equity Share Capital	As at March 31, 2021	As at March 31, 2020
Authorised Share Capital		
12,50,00,000 (previous year- 12,50,00,000) equity shares of Rs. 2/- each	2,500.00	2,500.00
Issued, Subscribed and Fully Paid Up		
10,00,00,000 (previous year- 10,00,00,000) equity shares of Rs 2/- each	2,000.00	2,000.00
Total	2,000.00	2,000.00

NOTES TO FINANCIAL STATEMENTS FOR THE YEAR ENDED MARCH 31, 2021

(All amounts are in lakhs unless otherwise stated)

	As at March 31, 2021	As at March 31, 2020
(i) Reconciliation of number and amount of equity shares outstanding:	No. of Shares	No. of Shares
At the beginning of the year	10,00,00,000	10,00,00,000
Changes during the year	-	-
Outstanding at the end of the year	10,00,00,000	10,00,00,000

Terms & right attached to equity shares

- a) The Company has only one class of equity shares having par value of Rs. 2/- per share. Each shareholder having equity shares is entitled to one vote per share. The company declares dividends in Indian Rupees. During the year ended March 31, 2021, the amount of dividend per share recognised as distributed to equity shareholder was Rs. NIL (March 31, 2020 Rs. NIL)
- b) Aggregate number of bonus shares issued, shares issued for consideration other than cash and shares bought back during the period of five years immediately preceding the reporting date.-Nil
- c) In the event of liquidation of the company, the holders of equity shares will be entitled to receive remaining assets of the company after distribution of the preferential amount, if any. The distribution will be in proportion to the number of equity shares held by the shareholders.

(ii) Details of shareholders holding more than 5% shares in the company

Particulars	As at March 31, 2021	As at March 31, 2020
Dayanand Munjal Investments Pvt Ltd (holding company)		
No. of Shares	7,47,95,950	7,47,95,950
% of Holding	74.80%	74.80%

As per the records of the company, including its register of shareholders/members and other declarations received from shareholders regarding beneficial interest, the above shareholding represents both legal and beneficial ownership of shares.

14 Financial Liability : Non Current

14.1 Borrowing	As at March 31, 2021	As at March 31, 2020
Term loans:		
i. From banks-Secured	28,732.98	23,222.26
Less: Shown in current maturities of long term borrowings*	(7,058.71)	(3,727.29)
ii. From others-Secured	1,109.00	-
Less: Shown in current maturities of long term borrowings*	-	-
iii. From others-Unsecured	702.47	1,951.49
Less: Shown in current maturities of long term borrowings*	(679.37)	(1,013.99)
iii. From related parties -Unsecured	3,860.00	-
Less: Shown in current maturities of long term borrowings*	(2,110.00)	-
IND AS Adjustment	(24.97)	(59.30)
Total	24,531.40	20,373.17

* Amount disclosed under the head 'other financial Liabilities' note no. 17.3

- (i) Note: Refer note -39 -I & II for borrowing terms and repayment of loan
- (ii) Note: Refer note -39 -III for defaults made in repayment of loans.

NOTES TO FINANCIAL STATEMENTS FOR THE YEAR ENDED MARCH 31, 2021

(All amounts are in lakhs unless otherwise stated)

- (iii) Note: During the year, Government has notified the Emergency Credit Line Guarantee Scheme (ECLGS) to support the borrower to bridge the gaps in working capital requirements which was affected due to pandemic. During the year, the company has availed Rs. 7,949.00 Lakhs under the said scheme. As per the ECLGS Scheme, Yes Bank Limited (one of the lenders) has provided the loan and the same is not being disbursed/adjusted with the existing borrowings. The above said loan is being carried in a current account maintained with the bank for future adjustment.

15	Provision	As at March 31, 2021	As at March 31, 2020
	Provision for employee benefits		
	- Gratuity	382.65	330.86
	- Leave Encashment	305.14	331.43
	Total	687.79	662.29

Refer note no.36

16	Other non-current liabilities	As at March 31, 2021	As at March 31, 2020
	Deferred Income - Government Grant	24.55	25.45
	Total	24.55	25.45

17 Financial Liability : Current

17.1	Short Term Borrowings	As at March 31, 2021	As at March 31, 2020
	Secured - at amortised cost		
	Bank		
	- Cash Credit	2,375.43	3,201.45
	- Working Capital Demand Loan	7,819.88	11,100.00
	Other		
	- Working Capital Demand Loan	3,500.00	3,500.00
	Total	13,695.31	17,801.45

Note: Refer note -39 II for borrowing terms and repayment of loan

17.2	Other trade Payables	As at March 31, 2021	As at March 31, 2020
	a) Micro, small and medium enterprises (Refer note no 33)	1,388.21	1,367.71
	b) Due to related party	627.68	281.85
	c) Others	5,839.70	8,529.30
	Total	7,855.59	10,178.86

NOTES TO FINANCIAL STATEMENTS FOR THE YEAR ENDED MARCH 31, 2021

(All amounts are in lakhs unless otherwise stated)

17.3 Other Financial Liabilities	As at March 31, 2021	As at March 31, 2020
Current maturities of long term debt		
a) From Banks	7,058.71	3,727.29
b) From others	679.37	1,013.99
c) From related parties	2,110.00	-
Security Deposit	52.36	52.81
Interest accrued and due on borrowings	151.68	-
Interest accrued but not due on borrowings	411.31	278.46
Retention Money	15.53	15.53
Unpaid Dividend*	23.44	31.19
Other Payables		
a) Capital Creditors	201.72	1,229.09
b) Accrued salary & Benefits **	569.01	389.98
c) Others	997.04	495.85
Total	12,270.17	7,234.20

* There are no amounts outstanding in respect of unpaid dividend for more than seven years to be transferred to Investor Education and Protection Fund.

** Includes Rs. 8.44 lakhs due to related parties (previous year Rs 11.48 lakhs)

Note: Refer note -39 -III for defaults made in repayment of loans.

18 Other current Liability	As at March 31, 2021	As at March 31, 2020
Withholding and other taxes	1,929.78	999.63
Advance from Customers	346.15	636.83
Deferred Income - Government Grant	0.91	0.91
Total	2,276.84	1,637.37

19 Provision for employee benefits	As at March 31, 2021	As at March 31, 2020
- Gratuity	8.45	7.68
- Leave Encashment	8.96	8.14
Total	17.41	15.82

Refer note no.36

20 Revenue From Operation	For the Year Ended March 31, 2021	For the Year Ended March 31, 2020
a) Sales of products	46,631.42	57,031.34
b) Other operating revenues		
From scrap sale	2,027.80	1,550.12
Sales - Others	81.93	128.42
From Job work	-	73.37
	2,109.73	1,751.91
Total Revenue From Operations	48,741.15	58,783.25

NOTES TO FINANCIAL STATEMENTS FOR THE YEAR ENDED MARCH 31, 2021

(All amounts are in lakhs unless otherwise stated)

21	Other Income	For the Year Ended March 31, 2021	For the Year Ended March 31, 2020
	a) Interest Income from bank deposits and others	54.93	37.66
	b) Gain on foreign exchange fluctuation	178.62	-
	c) Miscellaneous receipts	116.63	58.64
	d) Profit on sale of property, plant and equipment's (net)	-	6.15
	e) Interest income at amortized cost	0.58	1.07
	f) Government grant	0.91	0.91
		351.67	104.43
22	Cost of Material Consumed	For the Year Ended March 31, 2021	For the Year Ended March 31, 2020
	Opening balance of the raw material inventory	1,485.60	1,634.36
	Add : Purchases during the year	16,551.43	23,922.07
		18,037.03	25,556.43
	Less: Closing balance of the raw material inventory	1,241.01	1,485.60
	Total cost of raw materials consumed	16,796.02	24,070.83
23	(Increase) / Decrease in Stocks	For the Year Ended March 31, 2021	For the Year Ended March 31, 2020
	Opening balance of the Inventories		
	Work - in - process	2326.43	3,336.32
	Finished goods	224.56	406.78
	Process scrap	85.57	43.36
		2,636.56	3,786.46
	Closing balance of the Inventories		
	Work - in - process	3,128.49	2,326.43
	Finished goods	407.78	224.56
	Process scrap	103.86	85.57
		3,640.13	2,636.56
	Net (Increase) / Decrease in Stocks	(1,003.57)	1,149.90
	Refer note no.34		
24	Employee benefit expenses	For the Year Ended March 31, 2021	For the Year Ended March 31, 2020
	Salaries, wages, allowances & commission including gratuity and retirement benefits	5490.30	5348.85
	Contribution to provident and other funds (Refer note no. 36(B)(v))	310.98	321.34
	Staff welfare expenses	340.10	458.43
		6,141.38	6,128.62

NOTES TO FINANCIAL STATEMENTS FOR THE YEAR ENDED MARCH 31, 2021

(All amounts are in lakhs unless otherwise stated)

25	Finance cost	For the Year Ended March 31, 2021	For the Year Ended March 31, 2020
	Interest on term loans	3,140.73	2,797.22
	Interest on cash credit	1,719.33	1,778.51
	Interest others (including cash discount)	658.92	500.72
	Interest on lease liabilities	96.72	113.82
	Other Borrowing Cost*	67.86	116.10
	Total Finance cost	5,683.56	5,306.37
	*Mainly consist of loan processing facilities from bank.		
26	Depreciation and Amortization	For the Year Ended March 31, 2021	For the Year Ended March 31, 2020
	a) Depreciation of tangible assets	4,692.26	5,158.64
	b) Amortization of Right-of use assets	116.51	147.77
	c) Amortization of intangible assets	63.51	74.83
	Total Depreciation and Amortization Expenses	4,872.28	5,381.24
27	Other expenses	For the Year Ended March 31, 2021	For the Year Ended March 31, 2020
	Power and fuel consumption	3,587.30	3,923.16
	Packing material consumption	187.89	187.29
	Repair and maintenance on		
	- Machinery	675.15	740.95
	- Building	228.14	234.06
	- Other	151.91	192.08
	Lease rent	28.65	55.21
	Wages to contractors	4,382.84	4,339.80
	Rates and taxes	82.68	64.66
	Corporate social responsibility expenses (Refer note no.2 below)	2.00	4.90
	Loss on sale of property, plant and equipment (net)	32.81	-
	Insurance	321.56	321.59
	Legal and professional	130.27	211.21
	Payment to auditor (Refer note no.1 below)	19.51	18.39
	Foreign Exchange losses (net)	-	68.58
	Travelling and conveyance	251.75	576.10
	Printing and stationery	1.08	2.11
	Postage, telegram and telephones	15.71	24.70
	Selling expenses	37.46	137.95
	Board & secretarial expenses	43.94	55.83
	Security expenses	210.82	277.05
	Freight and forwarding charges	541.15	623.54
	Provision for doubtful debts	145.90	452.00
	Miscellaneous expenses	210.57	138.47
	Total Other Expenses	11,289.09	12,649.63

NOTES TO FINANCIAL STATEMENTS FOR THE YEAR ENDED MARCH 31, 2021

(All amounts are in lakhs unless otherwise stated)

Other expenses	For the Year Ended March 31, 2021	For the Year Ended March 31, 2020
Note 1: Payment to auditor		
As auditor:		
- Audit Fee	10.50	11.16
- Limited review	4.50	4.50
- Certification/other services	4.00	1.40
Reimbursement of expenses	0.51	1.33
	19.51	18.39

Note 2: Corporate social responsibility expenses

Details of expenditure on corporate social responsibility activities as per Section 135 of Companies Act, 2013.

Particulars	For the Year Ended March 31, 2021	For the Year Ended March 31, 2020
1. Gross amount required to be spent by the company during the year		
2. Amount spent during the year		
Education	2.00	3.70
Others	-	1.20
	2.00	4.90

28 Tax Expense	For the Year Ended March 31, 2021	For the Year Ended March 31, 2020
(a) Current tax	-	-
Deferred Tax	(354.55)	(1,710.79)
Deferred Tax - Ind AS	20.40	20.15
Earlier year tax adjustment	154.51	-
	(179.64)	(1,690.64)
(b) Reconciliation of effective tax rate		
Tax expense		
Profit before tax	(2,452.63)	(5,424.23)
Add: Interest on Tax as grouped in finance cost		
Less: Other comprehensive income	20.40	20.15
Add: Ind AS Adjustment	35.48	62.52
	(2,396.75)	(5,341.55)
Applicable tax rate	34.944%	34.944%
Computed tax expense	(837.52)	(1,866.55)
Total Tax Expense	(837.52)	(1,866.55)

NOTES TO FINANCIAL STATEMENTS FOR THE YEAR ENDED MARCH 31, 2021

(All amounts are in lakhs unless otherwise stated)

Tax Expense		For the Year Ended March 31, 2021	For the Year Ended March 31, 2020
Adjustments for:			
Income exempt for tax purpose			
Expenses not allowed for tax purpose		61.26	182.04
Brought forward unabsorbed depreciation setoff		-	-
Changes in recognized deductible temporary differences		3.26	45.15
Other Tax Adjustments		438.86	(51.28)
Earlier year tax adjustment		154.51	-
Net adjustments		657.88	175.92
Tax Expense		(179.64)	(1,690.64)
29	Other Comprehensive Income	For the Year Ended March 31, 2021	For the Year Ended March 31, 2020
Item that will not be reclassified to profit or loss			
Re-measurement of defined benefit plans		58.37	(57.67)
Income tax relating to items that will not be reclassified to profit or loss		(20.40)	20.15
Total Other Comprehensive Income		37.97	(37.52)
30	Earning per Share	For the Year Ended March 31, 2021	For the Year Ended March 31, 2020
Net profit for calculation of basic and diluted EPS (Rs. In Lakhs)		(2,252.56)	(3,713.44)
Total number of equity shares outstanding at the end of the year		10,00,00,000	10,00,00,000
Weighted average number of equity shares in calculating basic and diluted EPS		10,00,00,000	10,00,00,000
		(2.25)	(3.71)
31	Contingent Liabilities (not provided for) in respect of:		
S.N.	Particulars	Year ended March 31, 2021	Year ended March 31, 2020
a)	Letter of credit opened by banks	-	1,183.37
b)	PF Liability where the cases are pending at various stages of appeal with the authorities	70.00	70.00
c)	Bank Guarantees	14.16	-
d)	Sales tax demands financial year 2014-15	247.01	-
e)	Sales tax demands for financial year 2015-16 (including interest)	30.71	-
f)	Sales tax demands for financial year 2016-17	107.19	-
g)	Traces demands **	17.39	-
h)	Income tax demands where the cases are pending at various stages of appeal with the authorities	-	534.91

Interest on above demands is not computed and demanded by the department, therefore interest amount is not included above except otherwise stated.

** The Traces demands have been extracted from the traces online portal.

NOTES TO FINANCIAL STATEMENTS FOR THE YEAR ENDED MARCH 31, 2021

(All amounts are in lakhs unless otherwise stated)

Contingent liabilities and claims against the Company not acknowledged as debts related to various matters (Refer Note (a) below)

- a) i) The company assesses its obligation arising in the normal course of business including pending litigation, proceeding with tax authorities and other long-term contracts. A provision for material foreseeable losses is recognised in accordance with the applicable accounting standards. Disclosure of contingent liabilities is made as applicable.
- ii) Based on favourable decision in similar cases, the company believes that there is a fair chance of favourable decision in respect of the items listed above and hence no provision is considered necessary against the same.

32 Commitments:

S.N.	Particulars	Year ended March 31, 2021	Year ended March 31, 2020
a)	Estimated amount of contracts remaining to be executed on capital account and not provided for (net of advances)	1,115.96	728.59
b)	Estimated amount of contracts remaining to be executed on other than capital account and not provided for (net of advances)	-	-

33 Details of Dues to Micro and Small Enterprises as per MSMED Act, 2006 to the extent of information available with the Company

S.N.	Particulars	Year ended March 31, 2021	Year ended March 31, 2020
a)	Principal amount and Interest due thereon remaining unpaid to any supplier as at end of each accounting year	1,533.09	1,432.71
b)	Interest paid by the Company in terms of Section 16 of the MSMED Act along with the amounts of the payment made to the supplier beyond the appointed day during the accounting year.	-	-
c)	the amount of interest due and payable for the year of delay in making payment (which have been paid but beyond the appointed day during the year) but without adding the interest specified under this Act	-	-
d)	the amount of interest accrued and remaining unpaid	144.88	65.00
e)	The amount of further interest remaining due and payable even in the succeeding years, until such date when the interest dues above are actually paid to the small enterprise for the purpose of disallowance as a deductible expenditure under section 23 of this Act.	-	-

Dues to Micro and Small Enterprises have been determined to the extent such parties have been identified on the basis of information collected by the management. This has been relied upon by the auditors.

34 Details of Opening and Closing Inventory of Finished Goods:

S.N.	Class of Product	Year ended March 31, 2021	Year ended March 31, 2020
a)	Opening stock		
	Gear Components	224.56	406.78
b)	Closing stock		
	Gear Components	407.78	224.56

NOTES TO FINANCIAL STATEMENTS FOR THE YEAR ENDED MARCH 31, 2021

(All amounts are in lakhs unless otherwise stated)

35 Segment Information**(i) General Disclosure**

The Company is primarily in the business of manufacture and sale of components to automotive original equipment manufacturers. Hence there is only one identified reportable segments as per Ind As 108 - Segment reporting.

The above reportable segments have been identified based on the significant components of the enterprise for which discrete financial information is available and are reviewed by the Chief operating decision maker (CODM) to assess the performance and allocate resources to the operating segments.

(ii) Entity wide disclosure required by IND AS 108 are made as follows:**a) Revenues from sale of products to external customers**

Particulars	Year ended March 31, 2021	Year ended March 31, 2020
India	46,971.53	57,888.40
Outside India	1,769.62	894.85
	48,741.15	58,783.25

b) Segment Assets

Total of non-current assets other than financial instruments, and deferred tax assets broken down by location of the assets, is shown below

Particulars	Year ended March 31, 2021	Year ended March 31, 2020
India	43,511.56	47,749.36
Outside India	-	-

(iii) Information about major customers:

Particulars	Year ended March 31, 2021		Year ended March 31, 2020	
	Amount	Percentage	Amount	Percentage
Hero Moto corp Limited	26,852.75	55%	36,017.83	61%

36 Employee Benefits - Gratuity & Post employment benefits

The Company has classified the various benefits provided to employees as under:-

A. Defined Contribution Plan

The Company makes contribution to statutory Provident Fund and Employee State Insurance in accordance with Employees Provident Fund and Miscellaneous Provision Act, 1952 and Employee State Insurance Act, 1948 respectively. This is post-employment benefit and is in the nature of defined contribution plan.

B. Defined Benefit Plan

Gratuity (being partly administered by a Trust) is computed as 15 days salary, for every recognized retirement / termination / resignation. The Gratuity plan for the company is a defined benefit scheme where annual contributions as per actuarial valuation are charged to the Statement of profit and loss.

The Company also has a leave encashment scheme with defined benefits for its employees. The Company makes provision for such liability in the books of accounts on the basis of year end actuarial valuation. No fund has been created for this scheme.

NOTES TO FINANCIAL STATEMENTS FOR THE YEAR ENDED MARCH 31, 2021

(All amounts are in lakhs unless otherwise stated)

For summarizing the components of net benefit expense recognized in the statement of profit and loss and the funded status and amounts recognized in the balance sheet for the respective plans, the details are as under

A. Statement of profit and loss

Net employee benefit expense

Particulars	2020-21		2019-20	
	Gratuity (Funded)	Leave encashment	Gratuity (Funded)	Leave encashment
Current Service cost	89.06	28.22	82.10	35.18
Net Interest cost	23.17	23.24	16.55	25.09
Expenses recognized in the statement of profit & loss	112.23	74.12	98.65	97.91

B. Balance Sheet

(i) Details of Plan assets/ (liabilities) for gratuity and Leave Encashment

Particulars	2020-21		2019-20	
	Gratuity (Funded)	Leave encashment	Gratuity (Funded)	Leave encashment
Defined benefit obligation	1,075.45	314.10	1,004.51	339.56
Fair value of plan assets	684.35	-	665.97	-
Net Asset/(Liability) recognized in the Balance Sheet	(391.10)	(314.10)	(338.54)	(339.56)

(ii) Changes in the present value of the defined benefit obligation are as follows:

Particulars	2020-21		2019-20	
	Gratuity (Funded)	Leave encashment	Gratuity (Funded)	Leave encashment
Opening defined benefit obligation	1,004.51	339.56	828.68	325.20
Interest cost	68.76	23.24	63.94	25.09
Current service cost	89.06	28.22	82.10	35.18
Past service cost	-	-	-	-
Benefit paid	(26.88)	(99.37)	(28.95)	(83.54)
Actuarial (gains)/losses on obligation	(60.00)	22.44	58.74	37.63
Closing defined benefit obligation	1,075.45	314.09	1,004.51	339.56

(iii) Changes in the fair value of plan assets (gratuity) are as follows:

Particulars	2020-21	2019-20
Opening fair value of plan assets	665.97	614.15
Actual return on Plan Assets	45.59	47.39
Contribution during the year	1.30	3.48
Benefit paid	(26.88)	(28.95)
Return on plan assets, excluding amount recognised in net interest expense	(1.63)	1.07
Acquisition Adjustment	-	28.83
Closing fair value of plan assets	684.35	665.97

NOTES TO FINANCIAL STATEMENTS FOR THE YEAR ENDED MARCH 31, 2021

(All amounts are in lakhs unless otherwise stated)

- (iv) **The principal assumptions used in determining gratuity obligations for the Company's plans are shown below:**

Particulars	2020-21 %	2019-20 %
Discount rate (%)	6.80%	6.85%
Expected salary increase (%)	6.00%	6.00%
Demographic Assumptions		
Mortality rate (% of IALM 06-08)	100%	100%
Retirement Age (year)	58 Years	58 Years
Attrition / Withdrawal rates, based on age (per annum)		
Up to 30 years	3.00%	3.00%
31 - 44 years	2.00%	2.00%
Above 44 years	1.00%	1.00%

The estimates of future salary increases considered in actuarial valuation, take account of inflation, seniority, promotion and other relevant factors, such as supply and demand in the employment market. The above information is certified by Actuary.

- v. **Contribution to defined contribution plans:**

Particulars	2020-21	2019-20
Provident fund	292.87	305.44
Employee State Insurance	10.59	14.90
Labour welfare fund	7.52	1.00
Total	310.98	321.34

- vi **Sensitivity analysis of the defined benefit obligation:**

Particulars	2020-21		2019-20	
	Gratuity (Funded)	Leave encashment	Gratuity (Funded)	Leave encashment
Impact of the change in discount rate				
Present value of obligation at the end of the period	1,075.46	314.32	1,004.51	339.57
Impact due to increase of 0.50%	472.64	138.62	438.98	148.98
Impact due to decrease of 0.50%	615.05	179.29	577.91	194.78
Impact of the change in salary increase				
Present value of obligation at the end of the period	1,075.46	314.32	1,004.51	339.57
Impact due to increase of 0.50%	614.53	179.24	577.45	194.75
Impact due to decrease of 0.50%	471.62	138.32	437.96	148.65

Sensitivities due to mortality & withdrawals are insignificant & hence ignored.

NOTES TO FINANCIAL STATEMENTS FOR THE YEAR ENDED MARCH 31, 2021

(All amounts are in lakhs unless otherwise stated)

vii Other comprehensive income (OCI):

Particulars	2020-21		2019-20	
	Gratuity (Funded)	Leave encashment	Gratuity (Funded)	Leave encashment
Actuarial (gains) / losses				
- changes in demographic assumptions	-	-	(0.29)	-
- changes in financial assumptions	7.05	-	108.70	-
- experience variance (i.e. Actual experience vs assumptions)	(67.05)	-	(49.67)	-
- others	-	-	-	-
Return on plan assets, excluding amount recognised in net expense	1.63	-	(1.07)	-
Re-measurement (or Actuarial) (gain)/ loss arising because of change in effect of asset ceiling	-	-	-	-
Components of defined benefit costs recognised in other comprehensive income	(58.37)	-	57.67	-

37 Related Party Transaction**a) List of Related Parties (as certified by the management)****(i) Key Managerial Personnel**

Mr. Neeraj Munjal, Managing Director

Dr. Anil Kumar Gupta, Non-Executive Director w.e.f. 09.08.2019

Mrs. Charu Munjal, Whole-Time Director

Mr. Davendra Ujlayan, VP- Finance

Mr. Dinesh Kumar Mishra, AGM- Finance from 10.02.2020 to 02.09.2020

Ms. Shivani Kakkar, Company Secretary upto 25.01.2020

Ms. Samta Bajaj, Company Secretary w.e.f 10.02.2020

Mrs. Jyothi Prasad, Independent Director w.e.f. 13.11.2019

Dr. Vinayshil Gautam- Independent Director, upto 25.09.2019

Mr. Sunil Chinubhai Vakil, Independent Director w.e.f. 21.12.2020

Mr. Sunil Kant Munjal- Independent Director, upto 24.09.2020

Mr. Bhagwan Dass Narang-Independent Director

(ii) Holding Company

Dayanand Munjal Investments Private Limited

(iii) Enterprises over which key management personnel and their relatives are able to exercise significant influence

Munjal Showa Limited

Pushti Metal Industries LLP

Earthly Possessions

Sunil Vakil Associates

NOTES TO FINANCIAL STATEMENTS FOR THE YEAR ENDED MARCH 31, 2021

(All amounts are in lakhs unless otherwise stated)

b) The following transactions were carried out with related parties in the ordinary course of business:

Nature of transaction	Key management		Enterprises over which key management personnel and their relatives are able to exercise significant influence		Total	
	2020-21	2019-20	2020-21	2019-20	2020-21	2019-20
Sale of Goods & Services						
Munjal Showa Limited			601.52	1,308.16	601.52	1,308.16
Pushti Metal Industries LLP			5.02	-	5.02	-
Purchase of goods and services						
Munjal Showa Limited			0.15	3.60	0.15	3.60
Pushti Metal Industries LLP			874.58	1,104.27	874.58	1,104.27
Earthly Possessions			802.16	885.21	802.16	885.21
Sunil Vakil Associates		-	8.25	-	8.25	-
Finance Cost						
Munjal Showa Limited			11.23	-	11.23	-
Dayanand Munjal Investment Pvt. Ltd.			279.62	-	279.62	-
Loans Taken						
Dayanand Munjal Investment Pvt. Ltd.			3,500.00	-	3,500.00	-
Munjal Showa Limited			560.00	-	560.00	-
Loans Repaid						
Munjal Showa Limited			200.00	-	200.00	-
Salary & perquisites						
Neeraj Munjal	176.06	176.06			176.06	176.06
Anil Kumar Gupta	-	35.63			-	35.63
Charu Munjal	80.21	80.06			80.21	80.06
Davendra Ujlayan	54.47	55.37			54.47	55.37
Dinesh Mishra	14.99	2.44			14.99	2.44
Shivani Kakkar	-	8.06			-	8.06
Samta Bajaj	4.48	0.68			4.48	0.68
Sitting fees						
Dr. Vinayshil Gautam	-	3.60			-	3.60
Mr. Sunil Kant Munjal	1.50	3.30			1.50	3.30
Mr Bhagwan das Narang	6.90	7.50			6.90	7.50
Dr. Anil Kumar Gupta	6.60	3.30			6.60	3.30
Mr. Sunil Chinubhai Vakil	1.50	-			1.50	-
Ms. Jyothi Prasad	6.00	1.80			6.00	1.80

NOTES TO FINANCIAL STATEMENTS FOR THE YEAR ENDED MARCH 31, 2021

(All amounts are in lakhs unless otherwise stated)

c) Balances Outstanding at Year End:

Nature of transaction	Key management		Enterprises over which key management personnel and their relatives are able to exercise significant influence		Total	
	2020-21	2019-20	2020-21	2019-20	2020-21	2019-20
Trade Receivable:						
Munjal Showa Limited			25.10	(7.70)	25.10	(7.70)
Trade Payable:						
Munjal Showa Limited			4.16	4.01	4.16	4.01
Pushti Metal Industries LLP			243.10	102.92	243.10	102.92
Earthly Possessions			380.42	174.92	380.42	174.92
Sunil Vakil Associates	2.90	-			2.90	-
Salary & perquisites payable:						
Neeraj Munjal	4.75	7.45			4.75	7.45
Charu Munjal	3.69	4.03			3.69	4.03
Anil Kumar Gupta	-	-			-	-
Borrowings:						
Dayanand Munjal Investment Pvt. Ltd.			3,500.00	-	3,500.00	-
Munjal Showa Limited			360.00	-	360.00	-
Interest Payable:						
Dayanand Munjal Investment Pvt. Ltd.			279.62	-	279.62	-
Munjal Showa Limited			5.56	-	5.56	-

Based on the recommendation of the Nomination and Remuneration Committee, all decisions relating to the remuneration of the directors are taken by the Board of Directors of the Company, in accordance with shareholder's approval, wherever necessary.

The sales to and purchases from related parties are made in the normal course of business and on terms equivalent to those that prevail in arm's length transactions.

Gratuity and leave liability is determined for all the employees on an overall basis, based on the actuarial valuation done by an independent actuary. The specific amount of gratuity and leave liability for KMP cannot be ascertained separately, except for the amount actually paid.

The above transactions for sale and purchase of goods and services are inclusive of GST, wherever applicable.

38 Operating Lease

(a) Operating lease arrangements

Office premises are taken on operating lease. There is no escalation clause in the lease agreement

(b) Future minimum rentals payables under non-cancellable operating lease:

Particulars	As at	As at
	March 31, 2021	March 31, 2020
Not later than one year	126.32	126.32
Later than one year and not later than five years	582.89	525.23
Later than five years	494.38	980.23
Total	1,203.59	1,631.78

NOTES TO FINANCIAL STATEMENTS FOR THE YEAR ENDED MARCH 31, 2021

(All amounts are in lakhs unless otherwise stated)

39 Summary of borrowing arrangement**I Long Term Borrowings****From Bank**

Particulars	As at March 31, 2021	As at March 31, 2020	Rate of interest	Security	Repayment terms
IDFC First Bank Limited	1,439.96	1,919.53	11.75%	First pari passu charge on the present and future Moveable Assets situated at Haridwar Plant	Repayable in 18 quarterly installments beginning from August, 2017
IDFC First Bank Limited - 15Cr	1,168.43	1,250.00	10.85%	First charge on entire fixed assets of Haridwar Plant (including land and building) excluding plant and machinery exclusively charged to other lenders.	Repayable in 66 Monthly Equal installments beginning from May, 2019
IDFC First Bank Limited - 28.5 Cr	1,445.25	1,708.16	10.85%	First charge on entire fixed assets of Haridwar Plant (including land and building) excluding plant and machinery exclusively charged to other lenders.	Repayable in 49 Monthly Equal installments beginning from October, 2018
IDFC First Bank Limited - ECLGS	1,640.00	-	9.25%	Second Pari Passu charge on- 1. Current Assets both present and future. 2. Fixed Assets of Haridwar Plant including Land and Building, except exclusively charged to other lenders.	Repayable in 48 Monthly Equal installments beginning from April, 2022
Kotak Mahindra Bank Limited	786.92	1,485.00	10%-11%	First pari passu on entire fixed assets of Rohtak & Bangalore Plant, respectively with other lenders.	Repayable in 19 quarterly installments beginning from December, 2016
Yes Bank Limited - 50 Cr	2,943.52	3,400.00	9%-10.5%	Exclusive charge on all the Assets procured out of Term Loan proceeds (1.2x to be maintained)	Repayable in 22 quarterly installments beginning from June, 2018
Yes Bank Limited - 50 Cr	4,271.72	4,365.00	8.50%-9.50%	First pari passu charge on Immovable & Movable Fixed Assets of Bangalore and Rohtak Plant (both present and future)	Repayable in 24 quarterly installments beginning from December, 2018
Yes Bank Limited - 100 Cr	7,493.74	6,313.62	9.5%-10.5%	1. Exclusive charge on all Moveable Fixed Assets of Binola Plant 2. First Pari passu charge on all Fixed Assets of Bangalore and Rohtak Plant 3. First Pari Passu charge on all Fixed Assets of Haridwar plant.	Repayable in 24 quarterly installments beginning from June, 2020

NOTES TO FINANCIAL STATEMENTS FOR THE YEAR ENDED MARCH 31, 2021

(All amounts are in lakhs unless otherwise stated)

Particulars	As at March 31, 2021	As at March 31, 2020	Rate of interest	Security	Repayment terms
Yes Bank Limited - ECLGS	4,100.00	-	9.00%	<ol style="list-style-type: none"> 1. Exclusive charge on Current assets financed through the said WCTL facility. 2. Second Charge on entire Current Assets of Rohtak & Bangalore plant. 3. Second Charge on existing charge on entire Current Assets of Binola and Haridwar Plants. 4. Second charge on entire Moveable Fixed Assets of Binola Plant. 5. Second Charge on existing charge on Immovable & entire Moveable Fixed Assets of Rohtak and Bangalore plants. 6. Second charge on all the assets procured out of proceeds of Term Loan 2, 4 & 5 of the Borrower. 	Repayable in 48 Monthly Equal installments beginning from March, 2022
HDFC Bank Limited - 55 Cr	1,717.50	2,000.00	10.00%	<ol style="list-style-type: none"> 1. First pari passu on fixed assets of all plants except Manesar with other lenders, Exclusive charge on movable fixed asset of manesar Plant. 2. First pari passu charge on present and future current assets of the Company Plants at Binola, Haridwar and Manesar. 3. First pari passu charge on equitable mortgage of factory land and building located at Binola, Haridwar, Rohtak and Bangalore Plant. 	Repayable in 36 monthly installment beginning from October, 2020
HDFC Bank Limited - ECLGS	1,100.00	-	8.20%	<ol style="list-style-type: none"> 1. Current Assets of the Company (Both Present and Future). 2. Movable Fixed assets of the Company at Binola Plant. Extension of second ranking charge over existing primary and collateral securities including mortgages created in favour of the Bank. 	Repayable in 48 Monthly Equal installments beginning from March, 2022

NOTES TO FINANCIAL STATEMENTS FOR THE YEAR ENDED MARCH 31, 2021

(All amounts are in lakhs unless otherwise stated)

Particulars	As at March 31, 2021	As at March 31, 2020	Rate of interest	Security	Repayment terms
HDFC Bank Limited - Other Loan	49.88	-	12.00%	Funded Interest Term Loan	One Time Repayment at maturity date of loans on September 23, 2023
RBL Bank Limited - 26 Cr	576.06	780.95	9.55%	First pari passu charge by the way of hypothecation on entire movable fixed assets (Plant and Machinery) of the Haridwar Plant First pari passu charge by the way of equitable mortgage on entire fixed assets (Land and Building) of the Haridwar Plant	Repayable in 42 monthly installment beginning from March, 2020
Total	28,732.98	23,222.26			

From Others

Hero FinCorp Limited	702.47	1,562.50	11.90%	Unsecured	Repayable in 9 quarterly installment beginning from July, 2019
Hero FinCorp Limited	-	388.99	11.50%	Unsecured	Repayable in 37 monthly installment beginning from August, 2017
Hero FinCorp-ECLGS	1,109.00	-	14.00%	Second Pari Passu charge on the present and future current assets of Binola and Haridwar Plant	Repayable in 48 Monthly Equal installments beginning from April, 2022
Dayanand Munjal Investments Private Limited	3,500.00	-	10.50%	Unsecured	Repayable in 4 Half Yearly installments after moratorium period of 1 year
Munjal Showa Limited	360.00	-	12.00%	Unsecured	Repayable in 4 Equal installments payable on 10th and 25th of each month by way of 2 equal monthly installments beginning from 10th April 2021
	5,671.47	1,951.49			
Ind As Impact	(24.97)	(59.30)			
Total	34,379.48	25,114.45			

NOTES TO FINANCIAL STATEMENTS FOR THE YEAR ENDED MARCH 31, 2021

(All amounts are in lakhs unless otherwise stated)

II Short Term Borrowings

From Bank - Cash Credit / Working Capital Demand Loan

Particulars	As at March 31, 2021	As at March 31, 2020	Security
Binola			
IDBI Bank Limited	(4.97)	-	
Hero FinCorp Limited	3,500.00	3,500.00	First pari-passu charge on present and future current assets of plants situated at Binola and Haridwar.
Kotak Mahindra Bank	-	-	
Haridwar			
IDFC First Bank Limited	1,679.72	4,039.90	1. First Pari Passu charge on Current Assets of Haridwar Plant- 45 cr 2. Exclusive Charge on all the current assets of Rohtak Plant- 5 Cr
Others			
HDFC Bank Limited	1,666.50	2,774.20	First pari passu charges on the current asset of Binola & Haridwar plant along with the other working capital bankers.
Yes Bank Limited	6,854.06	7,487.35	Exclusive charges on all the current assets of Bengaluru plant and first pari pasu charge on all the current assets of Binola & Haridwar plant of the Borrower (Present & future)
Total	13,695.31	17,801.45	

III Delay in repayment of borrowings (current and non current) and interest

Amount represents Rs. in lakhs and period represents maximum days

Sr.	Name of lender	Borrowings/Principal		Interest		Remarks
		Outstanding as at March 31, 2021		Outstanding as at March 31, 2021		
		Amount	Period (in days)	Amount	Period (in days)	
1	Hero FinCorp Limited - 25 CR	-	-	40.76*	-	
2	Hero FinCorp Limited - 30 CR	-	-	22.53*	-	
3	Hero FinCorp Limited - ECLGS	-	-	12.94	1	Subsequently repaid on 05-04-2021
4	Hero Fincorp Limited - Working Capital Demand Loan	3,500.00	4	-	-	Subsequently repaid on 31-05-2021
5	Hero Fincorp Limited - Working Capital Demand Loan	-	-	33.54	4	Subsequently repaid on 18-05-2021
6	Hero Fincorp Limited - Working Capital Demand Loan	-	-	5.61*	-	
7	Yes Bank Limited - 100Cr	85.24	21	-	-	Subsequently repaid on 19-04-2021
8	Yes Bank Limited - 50Cr - Term Loan -2	194.00	23	-	-	Subsequently repaid on 19-04-2021

NOTES TO FINANCIAL STATEMENTS FOR THE YEAR ENDED MARCH 31, 2021

(All amounts are in lakhs unless otherwise stated)

Sr.	Name of lender	Borrowings/Principal		Interest		Remarks
		Outstanding as at March 31, 2021		Outstanding as at March 31, 2021		
		Amount	Period (in days)	Amount	Period (in days)	
9	Yes Bank Limited - ECLGS	-	-	31.34	1	Subsequently repaid on 19-04-2021
10	Yes Bank Limited - Funded Interest Term Loan	50.18	1	0.33	1	Subsequently repaid on 19-04-2021
11	Yes Bank Limited- Funded Interest Term Loan	10.10	23	-	-	Subsequently repaid on 19-04-2021
12	Yes Bank Limited- Funded Interest Term Loan	3.85	3	-	-	Subsequently repaid on 19-04-2021
13	RBL Bank Limited	19.05	1	4.63	1	Subsequently repaid on 04-04-2021

* overdues days has not been calculated as overdue charges imposed by the lenders on various dates.

IV Note on Delays in repayment of loans

Due to disruption in the operations owing to the outbreak of Covid-19 pandemic, liquidity profile of the company weakened resulting in delays in debt servicing. The liquidity position is delicately poised due to high working capital utilization and working capital intensive nature of operations and cyclical nature of auto sector.

In order to overcome stress owing to COVID 19 situation, the Company had proposed debt resolution under the RBI notification on the one-Time Resolution Framework for COVID-19-related Stress dated August 6, 2020 read together with the RBI notification on Resolution Framework for COVID-19-related Stress – Financial Parameters dated September 7, 2020 to lenders (“OTR”). For the same, the Company discuss the way forward through OTR and subsequently a formal request for invocation of OTR framework was shared with the lenders on September 27, 2020.

Thereafter, owing to stress on account of COVID-19, the Indian government announced the Emergency Credit Line Guarantee Scheme (“ECLGS”) under the third tranche of the “Atmanirbhar Bharat Package” on November 12, 2020, which allowed 100% guaranteed collateral free pre-approved sanction limit of up to 20% of outstanding as on February 29, 2020. Considering the revival in the industry and Company witnessing a turnaround, Company in discussions with its lenders decided to withdraw its OTR proposal and opt for the ECLGS facility in December 2020. Post submission of its request for withdrawing from OTR scheme, Company had cleared its outstanding with all the lenders. Further, the Company has over dues as on March 31, 2021, which was also cleared within 30 days.

Considering the fulfilment of conditions and compliances framed under the ECLGS, there were delays in servicing the loans. However these had not impacted the implementation of the Scheme and the said scheme was successfully implemented before March 31, 2021.

40 Financial Risk Management

Financial risk management objectives and policies:

The Company, as an internationally active supplier for the automobile industry expose its business and products to various market risks, credit risk and liquidity risk. The Company realizes that risks are inherent and integral aspect of any business. The primary focus is to foresee the unpredictability of financial markets and seek to minimize potential adverse effects on its financial performance. The Company's senior management oversees the management of these risks and devise appropriate risk management framework for the Company. The senior management provides assurance that the Company's financial risk activities are governed by appropriate policies and procedures and that financial risks are identified, measured and managed in accordance with the Company's policies and risk objectives.

NOTES TO FINANCIAL STATEMENTS FOR THE YEAR ENDED MARCH 31, 2021

(All amounts are in lakhs unless otherwise stated)

Below notes explain the sources of risks in which the Company is exposed to and how it manages the risks:

A Market Risk

Market risk is the risk that the fair value of future cash flows of a financial instrument will fluctuate because of changes in market prices. The Company is exposed to the risk of movements in interest rates, inventory price and foreign currency exchange rates that affects its assets, liabilities and future transactions. The Company is exposed to following key market risks:

a) Interest rate risk

Interest rate risk is the risk that the fair value of future cash flows of the financial instruments will fluctuate because of changes in market interest rates. The Company's main interest rate risk arises from long-term borrowings with variable rates, which exposes the Company to cash flow interest rate risk. During March 31, 2021 and March 31, 2020, the Company's borrowings at variable rate were mainly denominated in INR.

Interest rate risk exposure - The exposure of the Company's borrowing to interest rate changes at the end of the reporting period are as follows:

Particulars	As at 31st March, 2021	As at 31st March, 2020
Variable Rate Borrowing	38,644.88	41,023.71
Fixed Rate Borrowing	9,454.88	1,951.49
Ind as Adjustment	(24.97)	(59.30)
Total	48,074.79	42,915.90

An analysis by maturities is provided in Note (c) Maturities of financial liabilities below.

Sensitivity analysis - For Floating rate liabilities, the analysis is prepared assuming the amount of the liability outstanding at the end of the reporting period was outstanding for the whole year.

Sensitivity on variable rate borrowings	Impact on Profit & Loss Account	
	For the year ended 31-03-2021	For the year ended 31-03-2020
Interest rate increase by 0.25%	96.61	102.56
Interest rate decrease by 0.25%	(96.61)	(102.56)

b) Price Risk

Fluctuation in commodity price in global market affects directly and indirectly the price of raw material and components used by the Company in its various products segment. Substantial pricing pressure from major OEMs to give price cuts and inability to pass on the increased cost to customers may also affect the profitability of the Company.

Key Raw material - As per the agreement with the customers, any increase in the raw material prices is passed on to the customer. But in some cases where the customer was already asking for reduction in prices, the company has to absorb the price increase.

c) Foreign Currency risk

Foreign currency risk is the risk that the fair value or future cash flows of an foreign exposure will fluctuate because of changes in foreign exchange rates. The Company's exposure to the risk of changes in foreign exchange rates relates primarily to the Company's export revenue and import of raw materials and other consumables.

NOTES TO FINANCIAL STATEMENTS FOR THE YEAR ENDED MARCH 31, 2021

(All amounts are in lakhs unless otherwise stated)

The unhedged foreign currency exposure is as follows:

Particulars	Trade Receivable		Trade Payables	
	Foreign Currency in Lakhs	Rs in lakhs	Foreign Currency in Lakhs	Rs in lakhs
Foreign Exposure as at March 31, 2021				
CHF	-	-	0.06	4.54
EUR	3.59	308.46	0.27	22.79
JPY	-	-	14.19	9.38
SGD	-	-	-	-
USD	7.62	557.79	0.89	64.81
Foreign Exposure as at March 31, 2020				
CHF	-	-	4.55	356.02
EUR	1.86	154.64	0.35	28.79
GBP	-	-	-	-
JPY	-	-	1,030.88	722.65
SGD	-	-	2.45	129.66
USD	5.98	450.60	0.95	71.93

The exposure of foreign currency risk is Rs. Nil (previous year Rs. Nil).

Foreign currency sensitivity

The following tables demonstrate the sensitivity to a reasonably possible change in foreign exchange rates, with all other variables held constant.

Particulars	Change in FCR / INR Rate	Impact on Profit & Loss Statements	
		For the year ended 31-03-2021	For the year ended 31-03-2020
USD	+ 50 basis points	3.37	2.51
	- 50 basis points	(3.37)	(2.51)
EURO	+ 50 basis points	1.66	0.76
	- 50 basis points	(1.66)	(0.76)
CHF	+ 50 basis points	(0.03)	(2.27)
	- 50 basis points	0.03	2.27
JPY	+ 50 basis points	(7.10)	(515.44)
	- 50 basis points	7.10	515.44
SGD	+ 50 basis points	-	(1.22)
	- 50 basis points	-	1.22

NOTES TO FINANCIAL STATEMENTS FOR THE YEAR ENDED MARCH 31, 2021

(All amounts are in lakhs unless otherwise stated)

B Credit risk:

Credit risk is the risk that a counter party will not meet its obligations under a financial instrument or customer contract, leading to a financial loss. The Company is exposed to credit risk from its operating activities (primarily trade receivables and advances to suppliers) and from its financing activities, including deposits and other financial instruments.

The Company has developed guidelines for the management of credit risk from trade receivables. The Company's primary customers are major Indian automobile manufacturers (OEMs) with good credit ratings. Non-OEM clients are subjected to credit assessments as a precautionary measure, and the adherence of all clients for payment on due dates is monitored on an on-going basis. An impairment analysis is performed at each reporting date on an individual basis for major clients. In addition, a large number of minor receivables are grouped into homogeneous groups and assessed for impairment collectively. The calculation is based on historical data. The maximum exposure to credit risk at the reporting date is the carrying value of each class of financial assets **disclosed in Note 44. The Company does not hold collateral as security except in case of few customers.** The Company evaluates the concentration of risk with respect to trade receivables as low, as its customers are located in several jurisdictions and industries and operate in largely independent markets.

Particulars	As at March 31, 2021			As at March 31, 2020		
	Upto 6 months	More than 6 months	Total	Upto 6 months	More than 6 months	Total
Gross carrying amount (A)	6,193.89	1,168.16	7,362.05	6,519.68	1,101.58	7,621.26
Expected Credit Losses (B)		623.64	623.64		477.75	477.75
Net Carrying Amount (A-B)	6,193.89	544.52	6,738.41	6,519.68	623.83	7,143.51

Credit risk from balances with banks and other financial asset is managed in accordance with the Company's approved investment policy. Investments of surplus funds are made only with approved counterparties and within credit limits assigned to each counterparty. Counterparty credit limits are reviewed on regular basis and the said limits gets revised as and when appropriate. The limits are set to minimise the concentration of risks and therefore mitigate financial loss through counterparty's potential failure to make payments. The Company has deposited liquid funds at various banking institutions. Primary banking institutions are major Indian and foreign banks. In long term credit ratings, these banking institutions are considered to be investment grade. Also, no impairment loss has been recorded in respect of fixed deposits that are with recognised commercial banks and are not past due.

C Liquidity risk:

The liquidity risk encompasses any risk that the Company cannot fully meet its financial obligations. To manage the liquidity risk, cash flow forecasting is performed in the operating divisions of the Company and aggregated by Company finance. The Company's finance monitors rolling forecasts of the Company's liquidity requirements to ensure it has sufficient cash to meet operational needs while maintaining sufficient headroom on its undrawn committed borrowing facilities / overdraft facilities at all times so that the Company does not breach borrowing limits or covenants (where applicable) on any of its borrowing facilities.

Table hereunder provides the current ratios of the Company as at the year end

Particulars	As at March 31, 2021	As at March 31, 2020
Total current assets	24,865.14	19,885.62
Total current liabilities	36,234.42	36,967.56
Current ratio	0.69	0.54

NOTES TO FINANCIAL STATEMENTS FOR THE YEAR ENDED MARCH 31, 2021

(All amounts are in lakhs unless otherwise stated)

The table below summarises the maturity profile of the Company's financial liabilities (Current and Non current):

	Particulars	Less than 1 year	1 to 5 years	> 5 years	Total
I	As at March 31, 2021				
(i)	Borrowings	23,518.42	23,383.92	1,172.45	48,074.79
(ii)	Lease liability	119.10	660.80	-	779.90
(iii)	Other Financial Liability	2,422.09	-	-	2,422.09
(iv)	Trade and other payable	7,855.59	-	-	7,855.59
	Total	33,915.19	24,044.72	1,172.45	59,132.37
II	As at March 31, 2020				
(i)	Borrowings	22,483.42	18,000.18	2,491.59	42,975.19
(ii)	Lease liability	99.85	887.19	-	987.04
(iii)	Other Financial Liability	2,492.92	-	-	2,492.92
(iv)	Trade and other payable	10,178.86	-	-	10,178.86
	Total	35,255.05	18,887.37	2,491.59	56,634.01

41 Financial Instrument - Disclosure

This section explains the judgements and estimates made in determining the fair values of the financial instruments that are recognised and measured at fair value. To provide an indication about the reliability of the inputs used in determining fair value, the Company has classified its financial instruments into the three levels prescribed under the accounting standard.

Financial Asset

Sl. No	Particulars	Note	Fair value hierarchy	As at March 31, 2021		As at March 31, 2020	
				Carrying Amount	Fair Value	Carrying Amount	Fair Value
	Financial assets designated at amortised cost	D	Level 2				
(a)	<u>Non Current</u>						
	- Loans			629.78	629.78	650.80	650.80
	- Others Financial Asset			715.72	715.72	355.73	355.73
(b)	<u>Current</u>						
	- Trade receivables*			6,738.41	6,738.41	7,143.51	7,143.51
	- Cash and cash equivalents*			5,327.34	5,327.34	321.36	321.36
	- Bank Balances			868.05	868.05	414.61	414.61
	- Loans			16.76	16.76	37.32	37.32
	- Others Financial Asset			302.28	302.28	27.26	27.26
	Total			14,598.34	14,598.34	8,950.59	8,950.59

NOTES TO FINANCIAL STATEMENTS FOR THE YEAR ENDED MARCH 31, 2021

(All amounts are in lakhs unless otherwise stated)

Financial Liability

Sl. No	Particulars	Note	Fair value hierarchy	As at March 31, 2021		As at March 31, 2020	
				Carrying Amount	Fair Value	Carrying Amount	Fair Value
	Financial liability designated at amortised cost	D	Level 2				
(a)	<u>Non Current</u>						
	- Borrowings			24,531.40	24,531.40	20,373.17	20,373.17
	- Lease liabilities			660.80	660.80	887.19	887.19
(b)	<u>Current</u>						
	- Borrowings*			13,695.31	13,695.31	17,801.45	17,801.45
	- Trade payables*			7,855.59	7,855.59	10,178.86	10,178.86
	- Lease liabilities			119.10	119.10	99.86	99.86
	- Other financial liabilities			12,270.17	12,270.17	7,234.20	7,234.20
	Total			59,132.37	59,132.37	56,574.73	56,574.73

A - Company has opted to fair value its mutual fund investment through profit & loss

B - Company has opted to fair value its quoted investments in equity share through OCI

C - As per Para D-15 of Appendix D of Ind AS 101, the first time adopter may chose to measure its investment in subsidiaries, JVs and Associates at cost or at fair value. Company has opted to value its investments in subsidiaries, JVs and Associates at cost.

D - Company has adopted effective rate of interest for calculating Interest. This has been calculated as the weighted average of effective interest rates calculated for each loan. In addition processing fees and transaction cost relating to each loan has also been considered for calculating effective interest rate.

* In case of trade receivables, cash and cash equivalents, trade payables, short term borrowings and other financial assets and liabilities it is assessed that the fair values approximate their carrying amounts largely due to the short-term maturities of these instruments.

Fair value hierarchy

Level 1 - Quoted prices (unadjusted) in active markets for identical assets or liabilities.

Level 2 - Inputs other than quoted prices included within Level 1 that are observable for the asset or liability, either directly (i.e. as prices) or indirectly (i.e. derived from prices). The fair values of the financial assets and financial liabilities included above have been determined in accordance with generally accepted pricing models based on a discounted cash flow analysis, with the most significant inputs being the discount rate that reflects the credit risk of counterparties

Level 3 - Inputs for the assets or liabilities that are not based on observable market data (unobservable inputs).

42 Capital Management

For the purpose of the Company's capital management, equity includes issued equity capital and all other equity reserves attributable to the equity shareholders and net debt includes interest bearing loans and borrowings less current investments and cash and cash equivalents. The Company's objectives when managing capital is to safeguard their ability to continue as a going concern, so that they can continue to provide returns for shareholders and benefits for other stakeholders, and maintain an optimal capital structure to reduce the cost of capital.

NOTES TO FINANCIAL STATEMENTS FOR THE YEAR ENDED MARCH 31, 2021

(All amounts are in lakhs unless otherwise stated)

The Company manages its capital structure and makes adjustments in light of changes in economic & financial conditions and the requirements of the financial covenants. The funding requirement is met through a mixture of equity, internal accruals, long term borrowings and short term borrowings. The Company monitors capital using a gearing ratio, which is net debt divided by total capital plus net debt.

In order to achieve this overall objective, the Company's capital management, amongst other things, aims to ensure that it meets financial covenants attached to the interest-bearing loans and borrowings that define capital structure requirements. During the year the Company has breached with these covenants. During the year lenders has imposed the penalties towards non-fulfillment of the covenants as per the loan agreements and the same has duly been accounted in financial statements wherever charged by the lenders.

No changes were made in the objectives, policies or processes for managing capital during the year ended 31st March, 2020 and 31st March, 2021.

Particulars	As at	As at
	March 31, 2021	March 31, 2020
Debt (i)	48,074.79	42,915.90
Cash and cash equivalents	(5,327.34)	(321.36)
Net Debt	42,747.45	42,594.54
Total Equity	11,302.14	13,516.73
Net debt to equity ratio (Gearing Ratio)	4.25	3.18

(i) Debt is defined as long-term and short-term borrowings

43 Impact of COVID

Covid-19 pandemic has rapidly spread throughout the world, including India. Governments in India and across the world have taken significant measures to curb the spread of the virus including imposing mandatory lockdowns and restrictions in activities. Consequently, Company's manufacturing plants and offices had to be closed down/operate under restrictions for a considerable period of time during the year. Lockdowns/restrictions have impacted the Company operationally including on commodity prices and consumer demand. More recently, the next wave of the pandemic has impacted India and the Company is monitoring the situation closely taking into account the directives from the Governments.

Management believes that it has taken into account all the possible impacts of known events arising from COVID-19 pandemic in the preparation of the financial statements including but not limited to its assessment of Company's liquidity and going concern, recoverable values of its property, plant and equipment, intangible assets and the net realisable values of other assets. However, given the effect of these lockdowns and restrictions on the overall economic activity and in particular on the automotive industry, the impact assessment of COVID-19 on the financial statement captions is subject to significant estimation uncertainties due to its nature and duration and, accordingly, the actual impacts in future may be different from those estimated as at the date of approval of these financial statements. The Company will continue to monitor any material changes to future economic conditions and consequential impact on its financial statements.

44 Trade receivables

The Company has identified certain trade receivables aggregating to Rs. 868.01 lakhs (PY Rs. 795.16 lakhs) , whose recovery is not as per the payment terms. Based on the management estimate and provisioning norms, the company has made provision for doubtful debt of Rs. 623.64 lakhs (PY Rs 477.75 lakhs).To take the remedial steps, the Company has initiated the legal action against some of the customers for recovery of aforesaid dues.

45 The Indian Parliament has approved the Code on Social Security, 2020 which would impact the contributions by the Company towards Provident Fund and Gratuity. The Ministry of Labour and Employment has released draft rules for the Code on Social Security, 2020 on November 13, 2020, and has invited suggestions from stakeholders, which are under active consideration by the Ministry. The Company will assess the impact and its evaluation once the subject

NOTES TO FINANCIAL STATEMENTS FOR THE YEAR ENDED MARCH 31, 2021

(All amounts are in lakhs unless otherwise stated)

rules are notified and will give appropriate impact in its financial statements in the period in which, the Code becomes effective and the related rules to determine the financial impact are published.

- 46** The Board of directors in its meeting held on December 28, 2019 considered and approved the further issue of Equity shares to the existing shareholders of the Company on Right basis upto Rs.50 crores in such ratio and proportion to their holdings on the record date as may be decided by the board in accordance with the provisions of the Section 23 and Section 62 and all other applicable provisions, if any, of the Companies Act, 2013 and rules made there under, Chapter III and other applicable regulations of Securities and Exchange Board of India (Issue of Capital and Disclosure Requirements) Regulations, 2018, as amended, the guidelines and / or regulations and/or circulars issued by the Securities and Exchange Board of India, the Listing Agreements entered with the Stock Exchanges pursuant to Securities And Exchange Board of India (Listing Obligations and Disclosure Requirements) Regulations, 2015 and subject to the such other approvals, permissions, consents, no objections and sanctions of the lenders of the Company, SEBI, Stock Exchange(s), RBI, Government of India and/or any other concerned regulatory authorities, as may be necessary.

Further for the purpose of giving effect to the Rights Issue, the Board may either by itself or has authorized a Committee of the Board, under the name and style of "Rights Issue Committee" to decide the other terms and conditions of the Rights Issue as may be required from time to time. Further, the Draft letter of offer has been placed and approved by the Board of Directors in the meeting held on June 09, 2021.

47 Events occurring After the Balance Sheet date

No adjusting or significant non adjusting events have occurred between the reporting date and date of authorization of financial statements

- 48** Previous year figures have been regrouped / reclassified wherever necessary to correspond with current year classification/ disclosure.

As per report of even date

For NSBP & Co.

Chartered Accountants

Firm Regn. No. 001075N

Sd/-

Deepak K. Aggarwal

Partner

Membership No. 095541

Place : New Delhi

Dated: June 09, 2021

**For & on behalf of the Board of Directors of
Shivam Autotech Limited**

Sd/-

Neeraj Munjal

Managing Director

DIN : 00037792

Sd/-

Davendra Ujlayan

VP- Finance

PAN: AAFPU2249C

Place : Gurugram

Dated: June 09, 2021

Sd/-

Charu Munjal

Whole Time Director

DIN: 03094545

Sd/-

Samta Bajaj

Company Secretary

M No 50269



10, 1st Floor, Emaar Digital Greens, Tower A, Sector 61,
Golf Course Extension Road, Gurugram, Haryana - 122102

Ph: 0124-4698700

E-mail: info@shivamautotech.com | www.shivamautotech.com