

REV. NO. 00

| | |
|----------------------|------------|
| IF IN DOUBT, PL. ASK | |
| DO NOT SCALE DRAWING | |
| APPROVED FOR | |
| DEVELOPMENT | PRODUCTION |
| ✓ | |

THIS DOCUMENT CONTAINS INFORMATION PROPRIETARY TO CLH GASEOUS FUEL APPLICATIONS PRIVATE LIMITED. ANY REPRODUCTION, DISCLOSURE, OR USE OF THIS DOCUMENT, OR ANY INFORMATION CONTAINED THEREIN IS EXPRESSLY PROHIBITED EXCEPT AS CLH GASEOUS FUEL APPLICATIONS PRIVATE LIMITED MAY OTHERWISE AGREE IN WRITING.

| CLASSIFICATION OF CHARACTERISTICS | |
|-----------------------------------|-----------------|
| ● | CRITICAL |
| ○ | MAJOR |
| ▲ | KEY INSTRUCTION |

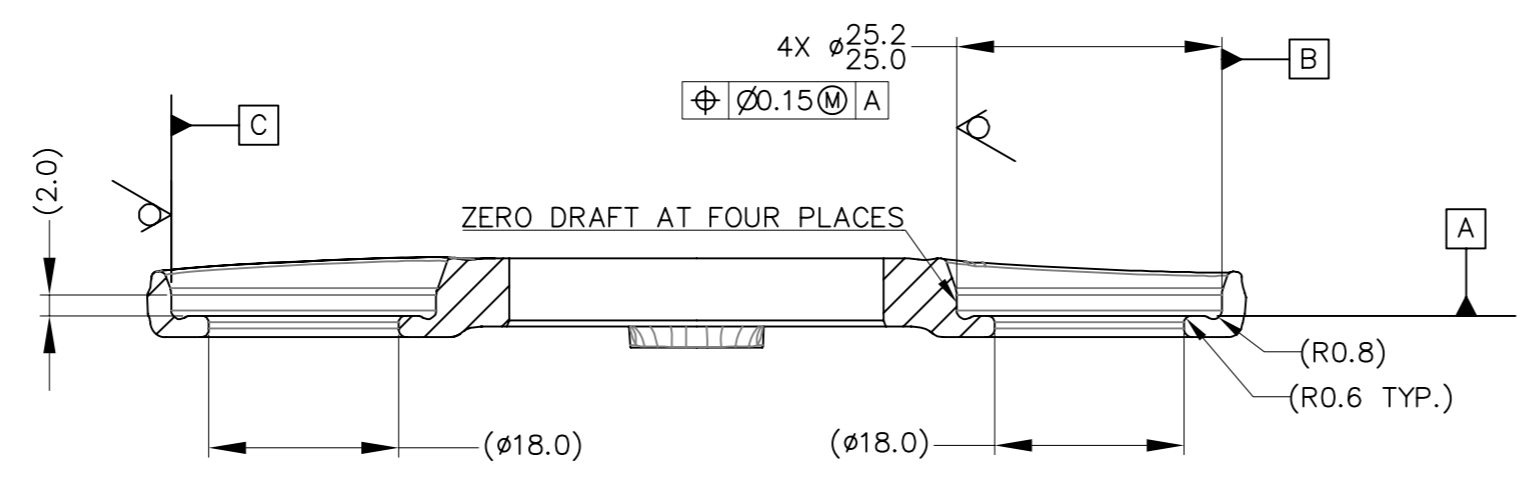
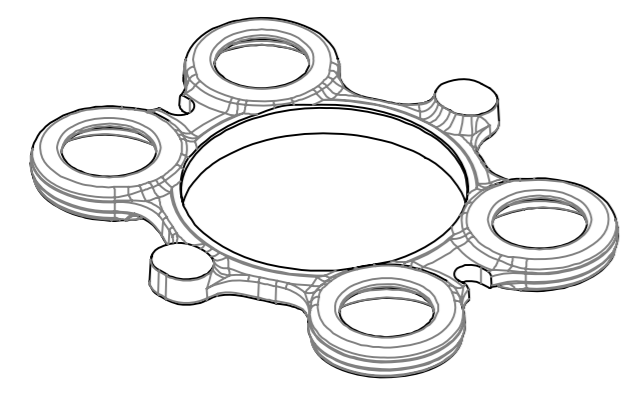

SECTION A-A

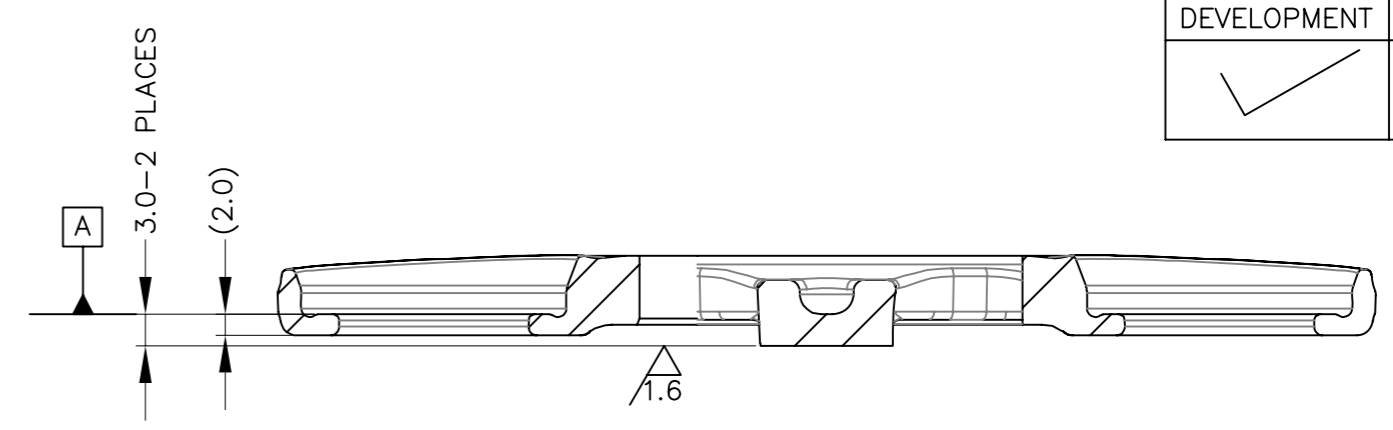

SECTION C-C

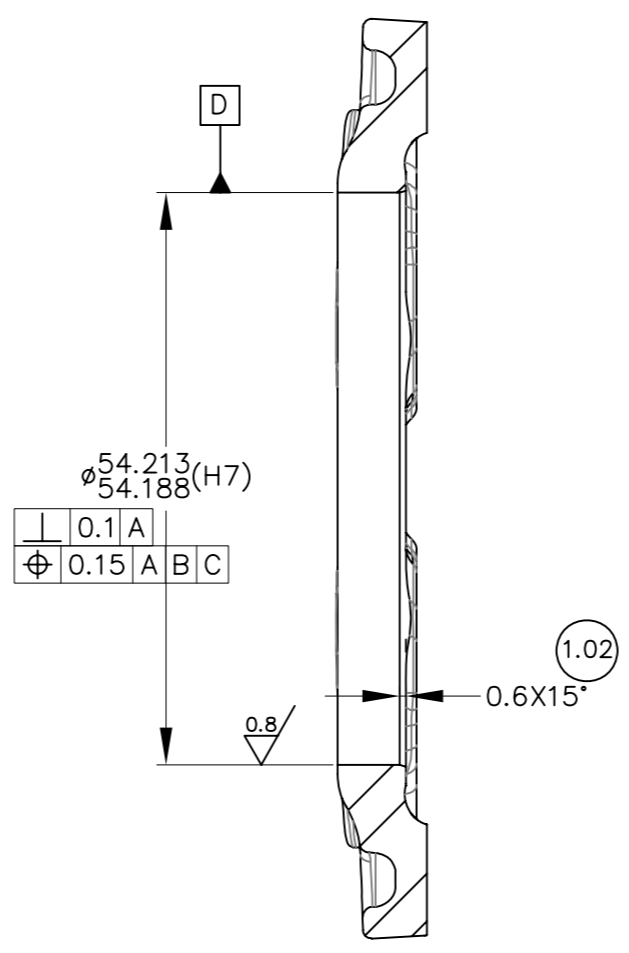
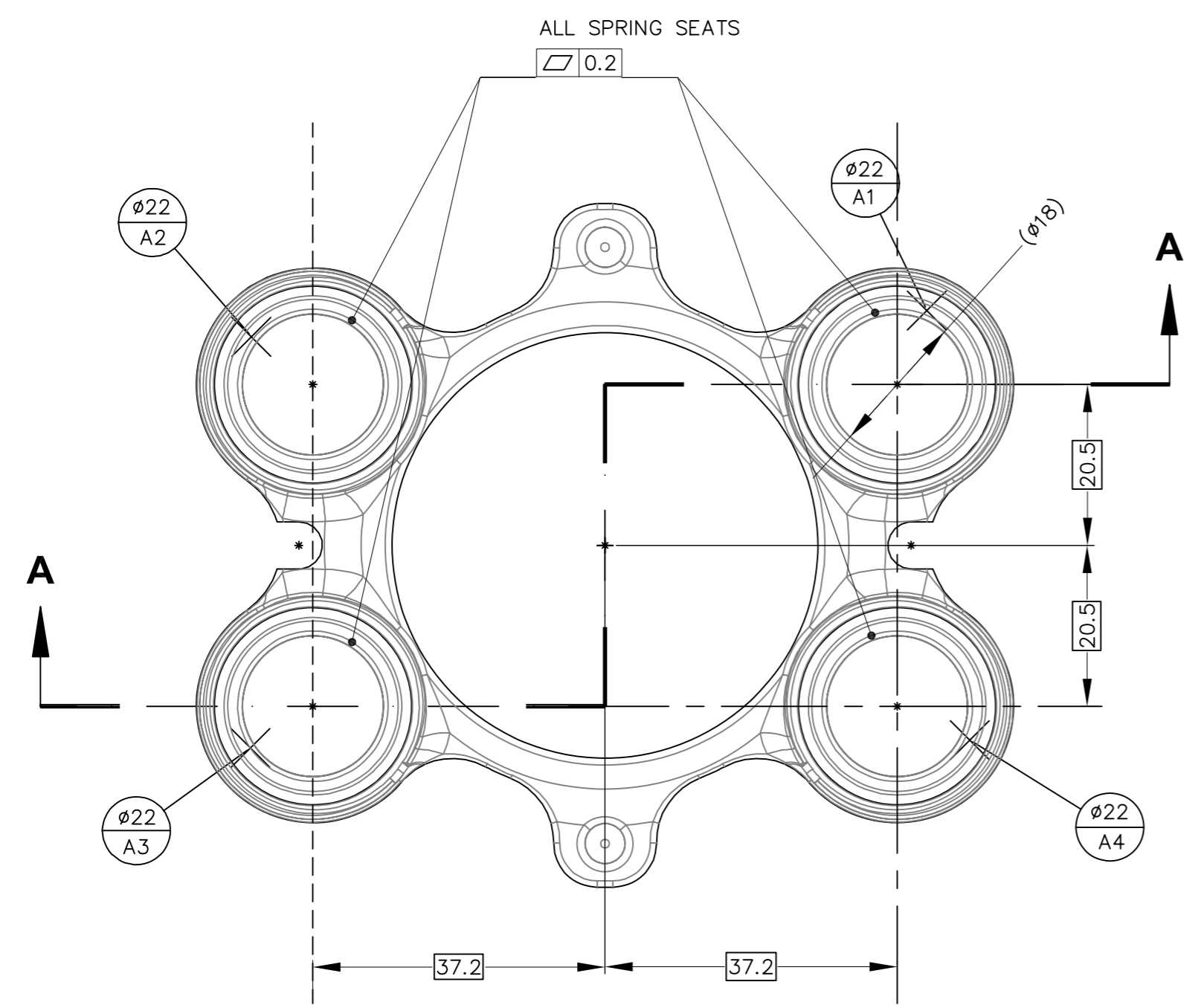

SECTION B-B

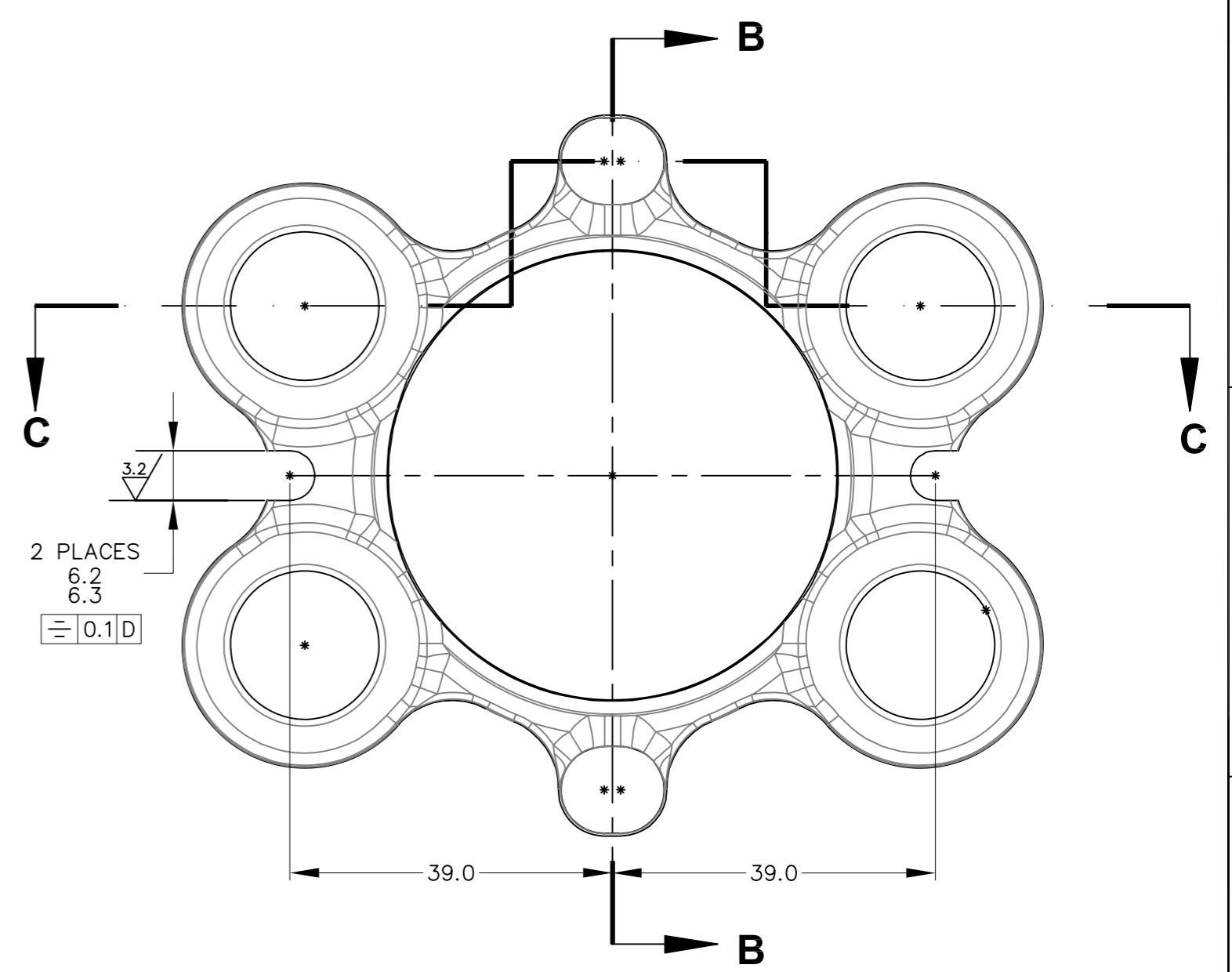

- NOTE:
- DATUM [A] IS DEFINED BY ALL SPRING MOUNTING FACE JOINTLY.
 - ALL UNSPECIFIED DIMENSIONS TO 3D MODEL [0.3] REVISION OF 3D MODEL TO MATCH OF THIS DRAWING.
 - ALL PART SURFACE TO BE COATED IN LIGHT OIL PRIOR TO SHIPPING.

◇ KEY PRODUCT CHARACTERISTIC
 ALL DIMENSIONS ARE IN MILLIMETERS
 LINEAR: 0.0±0.25mm
 ANGULAR: 0±1°
 GD&T PER ASME Y14.5-2009
 BREAK SHARP EDGES 0.1mm-0.3mm
 PACKAGE AND PROTECT AT ALL TIMES
 THREAD STANDARDS:
 METRIC IMPERIAL
 INTERNAL: BS3643 6H BS1580 2B
 EXTERNAL: BS3643 6g BS1580 2A
 FIRST THREADS TO BE REMOVED:
 0.5X45° UP TO 8mm. 1.0X45° OVER 8mm
 IF ANY DOUBT, ASK

| REV.No. | DESCRIPTION | REF./ECN | DATE | DRN. | CHD. | APPD. |
|--|-------------|---|----------|--|------|-------|
| | | | 30.03.18 | | | |
| NOTES :- ALL DIMENSIONS ARE IN MM. REMOVE BURRS & SHARP EDGES. TOLERANCES UNLESS STATED AS PER IS:2102, PART 1 FINE..... FINISH :- | | MATERIAL AISI4140/SCM440 | | SCALE 1:1 | | |
| PART FOR CLH | | DESCRIPTION SPRING RETAINER PRE ASSY. MACHINING | | DRG. NO. ZOST-LA-5668 SHEET 1 OF 1 | | |
| CLH GASEOUS FUEL APPLICATIONS PVT.LTD. | | A2 | | | | |